

KING SAUD UNIVERSITY

# Translation of Engineering & Petroleum Texts

---

TRAJ 474

**Mrs. Sarah Alajlan**

**Spring 2017**



Translation of Engineering & Petroleum Texts Syllabus – Spring 2017

<b>Course Code &amp; No.:</b> TRAJ 474	<b>Credit Hours:</b> 2	<b>Course Instructor:</b> Sarah Alajlan	<b>Semester:</b> 2 <sup>nd</sup> , Spring 2017
<p><b>Main Course Goals:</b> This course is to examine with students the practical issues involved in Petroleum translation. The students will have an opportunity to learn the various steps that the industry of Petroleum passes through starting from prospecting to oil markets and the political and economic impact of oil industry.</p> <p>This course is essentially practical in that it concentrates through regular home and class assignments followed by discussions of the students' work, on translating representative and graded petroleum texts. Emphasis will be laid upon the development of students' autonomy and problem-solving abilities.</p> <p>This course aims at equipping students with the skills of practical E/A translation of texts in the fields of petroleum. Special emphasis is laid on developing in Ss. the skills of speed, accuracy and faithfulness. They will also be made aware of the stylistic features of such texts.</p> <p>Developing advanced translation skills and receiving practical training in authentic engineering texts covering major branches of the field such as mechanical, chemical, petroleum, civil engineering, architecture (Islamic &amp; ancient Egyptian, etc.</p> <p>Developing the students' skills of speed, accuracy and fidelity.</p>			
<b>Course texts:</b> Texts are chosen from different sources available at <i>COLT'S Photocopy Center</i> 1 <sup>st</sup> floor			
<b>Required references:</b> <i>A New Dictionary of Scientific &amp; Technical Terms</i> , by: Ahmad Al-Khatib, Librairie du Liban Publishers.			
<p><b>Assessment:</b>            1<sup>st</sup> in-term: 25%            2<sup>nd</sup> in-term: 25%            Assignment: 10%            Final exam: 40%</p>			
<b>Office:</b> 2nd floor, room 12-4	<b>Office hours:</b> Sun. 10:00-12:00, Mon. 10:00-11:00, Tues. 10:00-11:00, Thurs. 10:00-11:00.		
<b>Instructor's Email:</b> <a href="mailto:salajlan@ksu.edu.sa">salajlan@ksu.edu.sa</a>	<b>Additional Contact Info:</b> Website: <a href="http://fac.ksu.edu.sa/salajlan">fac.ksu.edu.sa/salajlan</a>		
<b>Absence Warning:</b> 25% & above	<b>Banning from final exam:</b> 25% & above		
<p><b>Important Reminders:</b></p> <p>(1) Since language accuracy is core to translation and interpreting, expect strict, detailed grading of all language errors, in all courses.</p> <p>(2) Right after being absent from an exam, a valid verifiable excuse must be presented to the exam committee for approval. Location: G/16</p> <p>(3) No points will be awarded for (a) cheating in any exam and/or (b) plagiarism: using other people's work without proper citation.</p> <p>For further info on KSU's plagiarism policies and detection tools, check this link:  <a href="http://35302.wikispaces.com/file/view/plagiarism+handbook+2011.pdf">http://35302.wikispaces.com/file/view/plagiarism+handbook+2011.pdf</a></p>			

- (4) A more severe penalty will be implemented upon repeated cheating and/or plagiarism.  
 (5) Abayas must be removed during class and exams; phones must be switched off and only used for emergencies.  
 (6) A Psychological Counseling Center is available to students on campus, if needed.

### Tentative Weekly Schedule

Week	Gregorian	Hijri	Lesson
1	Sun., Feb. 5	8/5/1438	Registration week (dropping/adding courses)
2	Sun., Feb. 12	15/5/1438	Introduction & translating text 1: Petroleum
3	Sun., Feb. 19	22/5/1438	Translating text 2: Offshore Drilling
4	Sun., Feb. 26	29/5/1438	Translating text 3: مراحل إنتاج النفط (page 1)
5	Sun., Mar. 5	5/6/1438	Translating text 3: مراحل إنتاج النفط (page 2)
6	Sun., Mar. 12	12/6/1438	Translating text 4 : Power Transmission Lines
7	Sun., Mar. 19	19/6/1438	<b>First In-term</b>
8	Sun., Mar. 26	26/6/1438	Translating text 5: نصائح في هندسة الديكور
<b>MID-SEMESTER BREAK</b>			
9	Sun., Apr. 9	12/7/1438	Translating text 6: الهندسة المدنية /السدود & discussion of exam papers
10	Sun., Apr. 16	19/7/1438	Translating text 7: HVAC
11	Sun., Apr. 23	26/7/1438	Translating text 8: Lubrication
12	Sun., Apr. 30	4/8/1438	<b>Second In-term</b>
13	Sun., May 7	11/8/1438	Translating text 9: Service information
14	Sun., May 14	18/8/1438	Revision & discussion of exam papers
15	Sun., May 21	25/8/1438	<b>COLT'S ORAL EXAMS WEEK</b>
Sun., May 28 – Thurs., June 15			<b>EXAMS</b>
<b>Summer Break (Students)</b>			Fri., June 16 – Sun. Sep., 10 <sup>th</sup>

## **TEXT 1**

### **Petroleum**

Petroleum (also known as crude oil or simply oil) is a fossil fuel that was formed from the remains of ancient marine organisms.

Millions of years ago, algae and plants lived in shallow seas. After dying and sinking to the seafloor, the organic material mixed with other sediments and was buried. Over millions of years under high pressure and high temperature, the remains of these organisms transformed into what we know today as fossil fuels. Coal, natural gas, and petroleum are all fossil fuels that formed under similar conditions.

Today, petroleum is found in vast underground reservoirs where ancient seas were located. Petroleum reservoirs can be found beneath land or the ocean floor. Their crude oil is extracted with giant drilling machines.

Crude oil is usually black or dark brown, but can also be yellowish, reddish, tan, or even greenish. Variations in color indicate the distinct chemical compositions of different supplies of crude oil. Petroleum that has few metals or sulfur, for instance, tends to be lighter (sometimes nearly clear).

Petroleum is used to make gasoline, an important product in our everyday lives. It is also processed and part of thousands of different items, including tires, refrigerators, life jackets, and anesthetics.

When petroleum products such as gasoline are burned for energy, they release toxic gases and high amounts of carbon dioxide, a greenhouse gas. Carbon helps regulate the Earth's atmospheric temperature, and adding to the natural balance by burning fossil fuels adversely

affects our climate.

There are huge quantities of petroleum found under Earth's surface and in tar pits that bubble to the surface. Petroleum even exists far below the deepest wells that are developed to extract it.

However, petroleum, like coal and natural gas, is a non-renewable source of energy. It took millions of years for it to form, and when it is extracted and consumed, there is no way for us to replace it.

Oil supplies will run out. Eventually, the world will reach "peak oil," or its highest production level. Some experts predict peak oil could come as soon as 2050. Finding alternatives to petroleum is crucial to global energy use, and is the focus of many industries.

## TEXT 2

### Offshore Drilling

Drilling for natural gas offshore, in some instances hundreds of miles away from the nearest landmass, poses a number of different challenges over drilling onshore. The actual drilling mechanism used to delve into the sea floor is much the same as can be found on an onshore rig. However, with drilling at sea, the sea floor can sometimes be thousands of feet below sea level. Therefore, while with onshore drilling the ground provides a platform from which to drill, at sea an artificial drilling platform must be constructed.

Since the land that is going to be drilled cannot provide a base for offshore drilling as it does for onshore drilling, an artificial platform must be created. This artificial platform can take many forms, depending on the characteristics of the well to be drilled, including how far underwater the drilling target is.

#### Moveable Offshore Drilling Rigs

There are two basic types of offshore drilling rigs: those that can be moved from place to place, allowing for drilling in multiple locations, and those rigs that are permanently placed. Moveable rigs are often used for exploratory purposes because they are much cheaper to use than permanent platforms. Once large deposits of hydrocarbons have been found, a permanent platform is built to allow their extraction. The sections below describe a number of different types of moveable offshore platforms.

#### Drilling Barges

Drilling barges are used mostly for inland, shallow water drilling. This typically takes place in lakes, swamps, rivers, and canals. Drilling barges are large, floating platforms, which must be towed by tugboat from location to location. Suitable for still, shallow waters, drilling barges are not able to withstand the water movement experienced in large open water situations.

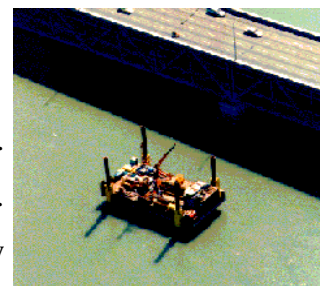

## Jack-Up Rigs

Jack-up rigs are similar to drilling barges, with one difference. Once a jack-up rig is towed to the drilling site, three or four 'legs' are lowered until they rest on the sea bottom. This allows the working platform to rest above the surface of the water, as opposed to a floating barge. However, jack-up rigs are suitable for shallower waters, as extending these legs down too deeply would be impractical. These rigs are typically safer to operate than drilling barges, as their working platform is elevated above the water level.



## TEXT 3

### مراحل إنتاج النفط

#### أولاً: الفصل

##### التقطير المبسط

مبدأ التقطير المبسط: تبخير ثم تكثيف

متى يستعمل : يستعمل لفصل مادتين فقط

##### التقطير التجزيئي

تعريفه: عملية فصل مكونات المخاليط في الحالة السائلة عن بعضها بتحويلها إلى بخار ثم إعادة تكثيف كل منها على حدة اعتماداً تفاوت درجات غليانها .

مبدأ عمل جهاز التقطير التجزيئي : تمر المكونات في عمود تجزئة بحيث إن المكونات مخفضة الغليان تصل إلى اعلي العمود تليها المكونات الأخرى حسب درجة غليانها .

برج التقطير : في مصافي النفط يقوم برج كبير يسمى برج تقطير بعمل العمود التجزئة في جهاز التجزيئي ويتميز هذا البرج بأنه يمكن سحب المكونات أماكن مختلفة منه.

##### خطوات تقطير النفط:

1-التبخير:يسخن النفط في أفران خاصة بعزل عن الهواء وفق تقنية التبادل الحراري.

تتبخر مكونات النفط فتتصاعد أبخرتها لأعلى.

##### 2-الفصل:

بالنسبة للغازات الذائبة في النفط : تنفصل الغازات المذابة في النفط بمجرد تسخين النفط ولا تكثف ثانية وتسحب من قمة البرج على صورتها الغازية..

بالنسبة لأبخرة المواد السائلة : عند صعود بخار النفط إلى اعلي برج التقطير تكثف أبخرة المواد السائلة واحدا تلو الآخر وينتم استخراج كل مائه منفصلة عند نقطة تكثفها عبر أنابيب خاصة .



## النواتج الأساسية لعملية التقطير :

1. المواد الغازية
2. الكيروسين
3. زيت التشحيم وشمع البارافين
4. الفار والإسفلت

## ثانياً: المعالجة والتنقية

عمل وحدة المعالجة والتنقية: يتم في وحده المعالجة والتنقية لتنقية المواد الناتجة من برج التكرير وإزالة الشوائب..

### طرق المعالجة والتنقية:

- 1- التنقية بالمعاملة الكيميائية : تستخدم مواد كيميائية لتنقية المادة المطلوبة من الشوائب مثل (الصودا الكاوية "هيدروكسيد الصوديوم" -حمض الكبريت - كلوريد النحاس)..
- 2- التنقية بالهدرجة: تنقية المواد النفطية كالنفثينات والكيروسين والديزل بتفاعلها مع غاز الهيدروجين وتتم تحت ضغط عال - درجة حرارة تتراوح بين 250 م و400 م -مع وجود مواد حفازة..

### ثالثاً: التحويل

عملية يتم فيها تحويل السوائل الثقيلة ذات الكتل الجزيئية الكبيرة إلى مواد خفيفة ذات كتل جزيئية صغيرة "اقل في عدد الكربونات " مثل الميثان والبروبان والبيوتان والجازولين..

- 1- التكسير الحراري: عملية تحويل المركبات العضوية الكبيرة إلى مركبات اصغر بواسطة الحرارة. المواد الناتجة من التكسير الحراري: هيدروكربونات مشبعة : تستعمل لإنتاج الطاقة وتحضير مركبات كيميائية جديدة. هيدروكربونات غير مشبعة: تستعمل في تحضير مركبات مفيدة خاصة في الصناعات الببتروكيميائية.
- 2- التكسير الحفزي : عملية تحويل الجزيئات العضوية الكبيرة إلى جزيئات اصغر باستخدام مواد كيميائية حفازة.

فوائد المواد الحفازة :

\* تزيد من سرعة عملية التكسير .

\*التكسير الحفزي أكثر دقة في تحديد نواتج عملية التكسير .

أمثلة للمواد الحفازة: ثاني أكسيد السيلكون - أكسيد الألومنيوم.

▪ لا تستخدم طريقة التكسير الحفزي إلا مع المواد الناتجة من برج التكرير.

**TEXT 4** (Electrical Engineering)

**Power Transmission Lines**

There are two types of power transmission lines: overhead lines and underground cables. When transmission lines are interconnected with each other, they form transmission networks known as power grid or the grid. Generation units in the power plants produce electricity with medium voltage. Then, the voltage is increased to extra high voltage by transformers. Extra high voltage makes electricity transmission more efficient over long distances. When electricity carried by power transmission lines reaches a load area, such as cities and factories, it comes into substations. Substations contain electrical components such as, circuit breakers, protection relays, transformers, and distributing bus-bars. In substations, voltage is decreased by transformers to either high voltage or medium voltage. Voltage is decreased to high voltage when it is used within the transmission system and it is decreased to medium voltage when it is connected to distribution system as shown in figure 2.

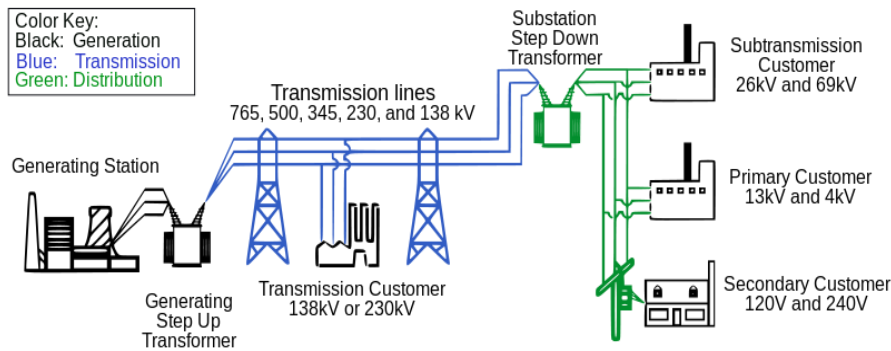

**Figure 1: Transmission System**

(Electric power transmission, 2012)

Power transmission lines usually operate with alternating current (AC). Direct current (DC) is used instead of AC to connect two transmission networks due to very long distances (above 500 km) and economic factors.

## 1. Overhead Lines

An overhead power line is an electric power transmission line suspended by towers. The amount of electric power on a power line at any given moment depends on generation production and power dispatch, customer use, the status of other transmission lines and their associated equipment and even the weather. The transmission system must accommodate changing electricity supply and demand conditions, unplanned outages, planned outages of generators or transmission equipment for maintenance, weather extremes, fuel shortages and other challenges such as, power lines overload currents which can lead to system-wide failure or a blackout.

Power plants generate a three-phase current. This means that there is a wire for each phase coming out of every plant and down the transmission lines. On a transmission structure, the three large wires are called conductors and carry the electric power. They are usually about an inch in diameter. There is also a smaller wire at the top of the structure, called a shield wire. The shield wire is designed to protect the power line from lightning and may also contain fiber optic communication cables.

There are several different kinds of transmission structures which can be constructed of metal or wood. They can be single-circuited, carrying one set of transmission lines or double-circuited with two sets of lines. Figure 3 shows an example of high voltage double-circuited transmission structures.



**Figure 2: Two High Voltage Double-Circuit Transmission Structures**

(Electric transmission lines, 2011)

## **2. Underground Cables**

Underground power lines or cables can be used instead of overhead lines because of technical and economic factors. Underground construction could be a reasonable alternative to overhead in urban areas, where an overhead line cannot be installed with appropriate clearance at any cost. In suburban areas, aesthetic issues, weather-related outages and some environmental concerns could make an underground option more attractive.

## TEXT 5

### نصائح في هندسة الديكور

يعتبر فن هندسة الديكور من الفنون التطبيقية التي تعتمد الي حد ما في خلفيتها علي الفنون الجميلة ويستغل فن هندسة الديكور احدث ما اخرجته عبقرية الانسان من مواد واختراعات فهذه الثورة بالازياء والمحلات التجارية واللمسات الفنية داخل المنزل كلها سواء كانت عفوية او مدروسة انما تتبع الحس الفني الطبيعي للانسان.

واسس التصميم هي - الوحدة -الاتزان- والانسجام - ونقطة التركيز - والحركة - والنسبة. وهذه العوامل قد تستخدم جميعا لعمل التصميم الداخلي لفراغ معين او تؤخذ على صورة فردية تعكس النظرة التصميمية للمصمم باستخدامها مرة واحدة او عدة مرات في التكوين الجمالي.

**وهندسة الديكور هي : تصميم الديكورات وخلق التوافق بين الاثاث والمكان والوان.**

وهندسة الديكور تدرس في كلية الفنون التطبيقية قسم الديكور وفي كلية الفنون الجميلة وكلية الفنون التطبيقية .

### التصميم من الناحية النظرية

ان التصميم في هندسة الديكور هو أول المراحل في الترتيب والأهمية عند القيام بعمل ديكور ما وعلي التصميم وحده يتوقف نجاح الديكور او فشله. فقبل أن نبدأ العمل في شراء اثاث اي غرفة مثلا يجب ان نضع تخطيط أولي لهذه الغرفة ولمساحتها وفراغها وارتفاعها أي بمعنى اخر دراسة الفراغ الداخلي للغرفة. ثم نبدأ بعمل التصميم او وضع خطوط اوليه لفكره الديكور لهذه الغرفة .

### يراعى في تخطيط والتصميم لهندسة الديكور الأمور التالية:

1. دراسه الفراغ الداخلي للغرفة بحيث يراعي عند اختار الاثاث مناسب في المساحه والارتفاع.
2. دراسه لون الاثاث بحيث يتناسب مع لون الستائر والحوائط ومؤائمه مع باقي الوان الغرف الاخري.
3. لايجب شراء الاثاث لهذه الغرفة الا اذا تكامل الشكل العام في ذهن المصمم ووضع تصور ما علي ورقه والتي تكون بمثابة وجهة نظره.

**الجمال في هندسة الديكور :** هناك نقطه لا بد من ان نحددها عندما نتحدث عن الجمال في هندسة الديكور. فتجد فنان يرسم فتاه ولكن لوحته تبدو غير موفقه وتفنقر الي الجمال بينما يرسم فنان اخر لوحه فنيه لفتاه تبدو غير جميله ولكن تكون لوحته في غاية الروعه. المراد من قولنا هذا ان الجمال ليس جمال الموضوع ولكن القدره علي الانسجام بين الشكل والموضوع هو اروع الجمال.

## TEXT 6 (Civil Engineering)

### الهندسة المدنية

الهندسة المدنية هي أحد فروع الهندسة والمعنية بدراسة وتصميم وتحليل المنشآت البشرية كالأبنية والطرق والجسور والأنفاق والمطارات والموانئ وشبكات الصرف الصحي والسدود وكذلك مشاريع الري، لذا لا يجوز حصر هذا العلم بأنه العلم المعني بالتصميم وحده فقط.

وهي كأي علم تتطور باستمرار ودون توقف وفي الآونة الحديثة ترابطت مع التطور الصناعي بشكل كبير لإنتاج مواد إنشائية جديدة ومتطورة تفي بالمتطلبات التي تكون دائماً متزايدة من المجتمع.

### السدود

السد هو إنشاء هندسي يقام فوق واد أو منخفض بهدف حجز المياه، السدود عمومًا تخدم الغرض الأساسي وهو الاحتفاظ بالمياه، في حين أن الهياكل الأخرى مثل الخنادق تستخدم لمنع تدفق المياه إلى مناطق محددة في الأرض. تضافرت الجهود للارتقاء بمستوى الموارد المائية، وتوفير ما من شأنه ضمان الحياة على سطح الأرض وذلك من خلال إقامة مشاريع السدود وتحقيق الاستفادة القصوى منها.

### أهداف السدود

الهدف الرئيسي من السدود هو الحفاظ على المياه من أجل الاستعمال القريب أو البعيد بمعنى الحفاظ عليها من أجل المستقبل مع إمكانية استخدامها في توليد الكهرباء.

### أنواع السدود

تنقسم السدود إلى قسمين:

1. السدود الخراسانية الاسمنتية
2. السدود الخراسانية الثقالية: وهي سدود ضخمة تقوم بمقاومة القوى الجبارة بشكل كلي من خلال أوزانها (قوة الجاذبية الأرضية) وجدارها (المانع الاسمطي) المصمم بطريقة هندسية ذات قواعد ضخمة ومتوازنة، وبالإضافة لمقاومتها للهزات الأرضية تتطلب هذه السدود الكثير من الاسمنت ولهذا تعتبر من أكثر السدود تكلفة.

### مختلف القوى المؤثرة على السد الثقلي

- قوى ناتجة عن ضغط وزن المواد المستخدمة في بناء السد.
- قوى ناتجة عن ضغط مياه الخزان.
- قوى ناتجة عن ضغط المياه في الفراغ.

## TEXT 7

(Mechanical Engineering)

### HVAC

**HVAC** (heating, ventilating/ventilation, and air conditioning) is the technology of indoor and vehicular environmental comfort. Its goal is to provide thermal comfort and acceptable indoor air quality. HVAC system design is a subdiscipline of mechanical engineering, based on the principles of thermodynamics, fluid mechanics, and heat transfer. Refrigeration is sometimes added to the field's abbreviation as HVAC&R or HVACR, or ventilating is dropped as in HACR (such as the designation of HACR-rated circuit breakers).

HVAC is an important part of residential structures such as single family homes, apartment buildings, hotels and senior living facilities, medium to large industrial and office buildings such as skyscrapers and hospitals, and in marine environments, where safe and healthy building conditions are regulated with respect to temperature and humidity, using fresh air from outdoors.

Ventilating or ventilation (the V in HVAC) is the process of exchanging or replacing air in any space to provide high indoor air quality which involves temperature control, oxygen replenishment, and removal of moisture, odors, smoke, heat, dust, airborne bacteria, carbon dioxide, and other gases. Ventilation removes unpleasant smells and excessive moisture, introduces outside air, keeps interior building air circulating, and prevents stagnation of the interior air.

Ventilation includes both the exchange of air to the outside as well as circulation of air within the building. It is one of the most important factors for maintaining acceptable indoor air quality in buildings. Methods for ventilating a building may be divided into mechanical/forced and natural types.

## **TEXT 8**

### **Lubrication**

Lubrication is the process or technique employed to reduce friction between, and wear of one or both, surfaces in proximity and moving relative to each other, by interposing a substance called a lubricant in between them. The lubricant can be a solid, a solid/liquid dispersion, a liquid such as oil or water, a liquid-liquid dispersion (a grease) or a gas.

With fluid lubricants the applied load is either carried by pressure generated within the liquid due to the frictional viscous resistance to motion of the lubricating fluid between the surfaces, or by the liquid being pumped under pressure between the surfaces.

Adequate lubrication allows smooth continuous operation of equipment, reduces the rate of wear, and prevents excessive stresses. When lubrication breaks down, components can rub destructively against each other, causing heat, local welding, destructive damage and failure.

Besides supporting the load the lubricant may have to perform other functions as well, for instance it may cool the contact areas and remove wear products. While carrying out these functions the lubricant is constantly replaced from the contact areas either by the relative movement (hydrodynamics) or by externally induced forces.

Lubrication is required for correct operation of mechanical systems pistons, pumps, cams, bearings, turbines, cutting tools etc. where without lubrication the pressure between the surfaces in close proximity would generate enough heat for rapid surface damage which in a coarsened condition may literally weld the surfaces together, causing seizure.

In some applications, such as piston engines, the film between the piston and the cylinder wall also seals the combustion chamber, preventing combustion gases from escaping into the crankcase.