

Chapter 26 Problems Solving

1. (a) How much charge is on each plate of a 4.00- μF capacitor when it is connected to a 12.0-V battery? (b) If this same capacitor is connected to a 1.50-V battery, what charge is stored?

$$(a) \quad Q = C\Delta V = (4.00 \times 10^{-6} \text{ F})(12.0 \text{ V}) = 4.80 \times 10^{-5} \text{ C} = \boxed{48.0 \mu\text{C}}$$

$$(b) \quad Q = C\Delta V = (4.00 \times 10^{-6} \text{ F})(1.50 \text{ V}) = 6.00 \times 10^{-6} \text{ C} = \boxed{6.00 \mu\text{C}}$$

4. (a) If a drop of liquid has capacitance 1.00 pF, what is its radius? (b) If another drop has radius 2.00 mm, what is its capacitance? (c) What is the charge on the smaller drop if its potential is 100 V?

$$(a) \quad C = 4\pi \epsilon_0 R$$

$$R = \frac{C}{4\pi \epsilon_0} = k_e C = (8.99 \times 10^9 \text{ N} \cdot \text{m}^2 / \text{C}^2)(1.00 \times 10^{-12} \text{ F}) = \boxed{8.99 \text{ mm}}$$

$$(b) \quad C = 4\pi \epsilon_0 R = \frac{4\pi(8.85 \times 10^{-12} \text{ C}^2)(2.00 \times 10^{-3} \text{ m})}{\text{N} \cdot \text{m}^2} = \boxed{0.222 \text{ pF}}$$

$$(c) \quad Q = CV = (2.22 \times 10^{-13} \text{ F})(100 \text{ V}) = \boxed{2.22 \times 10^{-11} \text{ C}}$$

6. Regarding the Earth and a cloud layer 800 m above the Earth as the “plates” of a capacitor, calculate the capacitance. Assume the cloud layer has an area of 1.00 km^2 and that the air between the cloud and the ground is pure and dry. Assume charge builds up on the cloud and on the ground until a uniform electric field of $3.00 \times 10^6 \text{ N/C}$ throughout the space between them makes the air break down and conduct electricity as a lightning bolt. What is the maximum charge the cloud can hold?

$$C = \frac{\kappa \epsilon_0 A}{d} = \frac{(1.00)(8.85 \times 10^{-12} \text{ C}^2/\text{N}\cdot\text{m}^2)(1.00 \times 10^3 \text{ m})^2}{800 \text{ m}} = \boxed{11.1 \text{ nF}}$$

The potential between ground and cloud is

$$\Delta V = Ed = (3.00 \times 10^6 \text{ N/C})(800 \text{ m}) = 2.40 \times 10^9 \text{ V}$$

$$Q = C(\Delta V) = (11.1 \times 10^{-9} \text{ C/V})(2.40 \times 10^9 \text{ V}) = \boxed{26.6 \text{ C}}$$

9. When a potential difference of 150 V is applied to the plates of a parallel-plate capacitor, the plates carry a surface charge density of 30.0 n C/cm^2 . What is the spacing between the plates?

$$Q = \frac{\epsilon_0 A}{d} (\Delta V)$$

$$\frac{Q}{A} = \sigma = \frac{\epsilon_0 (\Delta V)}{d}$$

$$d = \frac{\epsilon_0 (\Delta V)}{\sigma} = \frac{(8.85 \times 10^{-12} \text{ C}^2/\text{N} \cdot \text{m}^2)(150 \text{ V})}{(30.0 \times 10^{-9} \text{ C/cm}^2)(1.00 \times 10^4 \text{ cm}^2/\text{m}^2)} = \boxed{4.42 \text{ } \mu\text{m}}$$

18. Evaluate the equivalent capacitance of the configuration shown in Figure. All the capacitors are identical, and each has capacitance C .

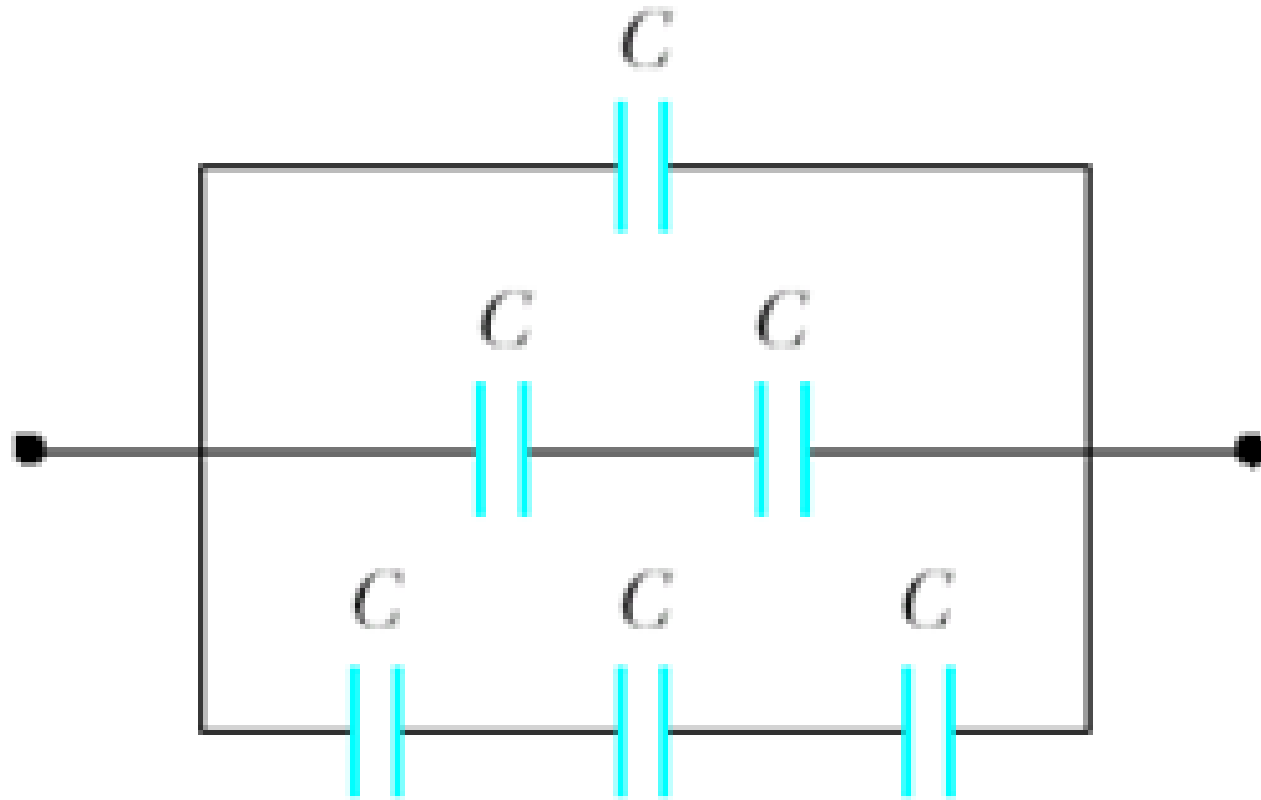

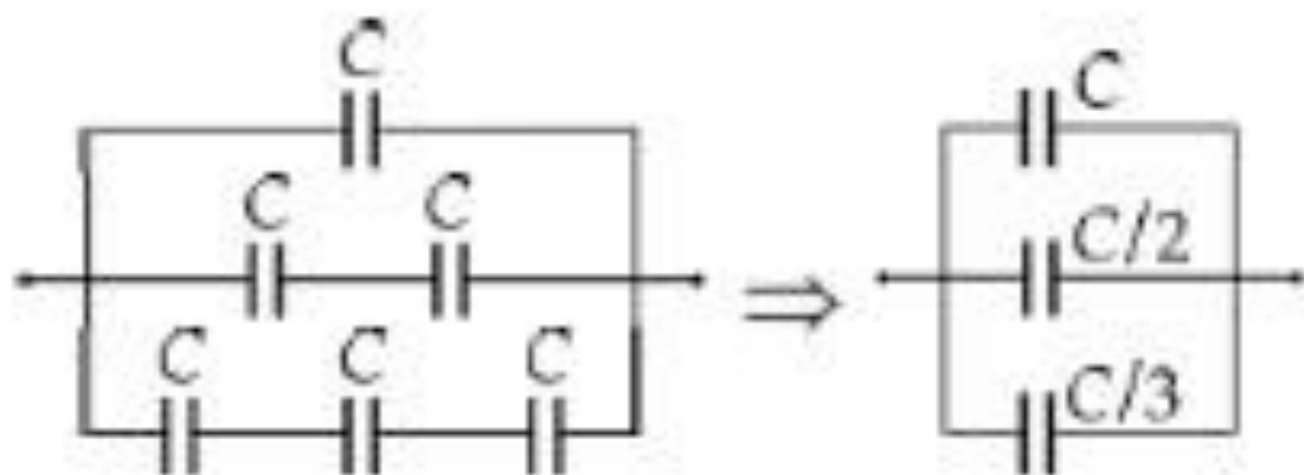

The circuit reduces first according to the rule for capacitors in series, as shown in the figure, then according to the rule for capacitors in parallel, shown below.

$$C_{\text{eq}} = C \left(1 + \frac{1}{2} + \frac{1}{3} \right) = \frac{11}{6} C = \boxed{1.83C}$$

21. Four capacitors are connected as shown in Figure P26.21. (a) Find the equivalent capacitance between points a and b . (b) Calculate the charge on each capacitor if $\Delta V_{ab} = 15.0$ V.

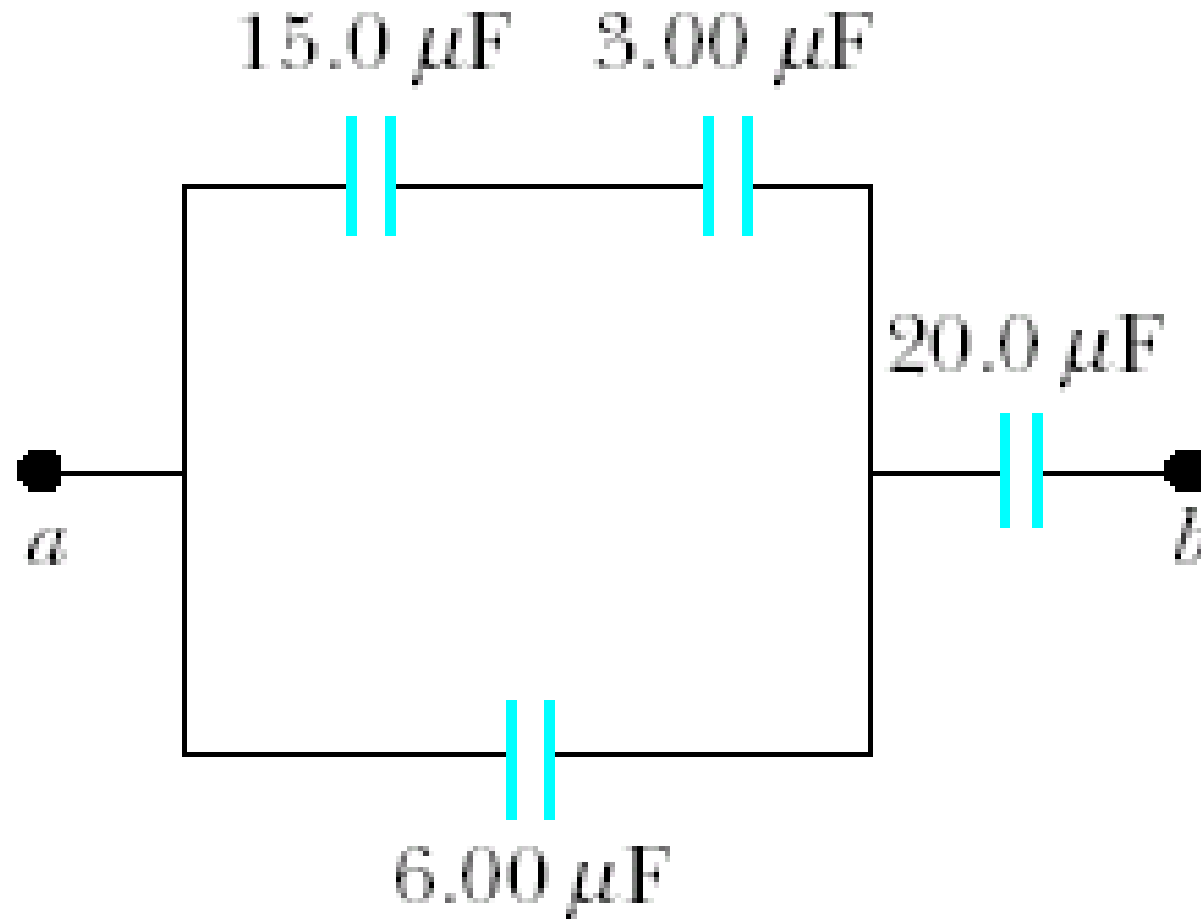

$$(a) \quad \frac{1}{C_s} = \frac{1}{15.0} + \frac{1}{3.00}$$

$$C_s = 2.50 \mu\text{F}$$

$$C_p = 2.50 + 6.00 = 8.50 \mu\text{F}$$

$$C_{eq} = \left(\frac{1}{8.50 \mu\text{F}} + \frac{1}{20.0 \mu\text{F}} \right)^{-1} = \boxed{5.96 \mu\text{F}}$$

$$(b) \quad Q = C\Delta V = (5.96 \mu\text{F})(15.0 \text{ V}) = \boxed{89.5 \mu\text{C}} \text{ on } 20.0 \mu\text{F}$$

$$\Delta V = \frac{Q}{C} = \frac{89.5 \mu\text{C}}{20.0 \mu\text{F}} = 4.47 \text{ V}$$

$$15.0 - 4.47 = 10.53 \text{ V}$$

$$Q = C\Delta V = (6.00 \mu\text{F})(10.53 \text{ V}) = \boxed{63.2 \mu\text{C}} \text{ on } 6.00 \mu\text{F}$$

$$89.5 - 63.2 = \boxed{26.3 \mu\text{C}} \text{ on } 15.0 \mu\text{F} \text{ and } 3.00 \mu\text{F}$$

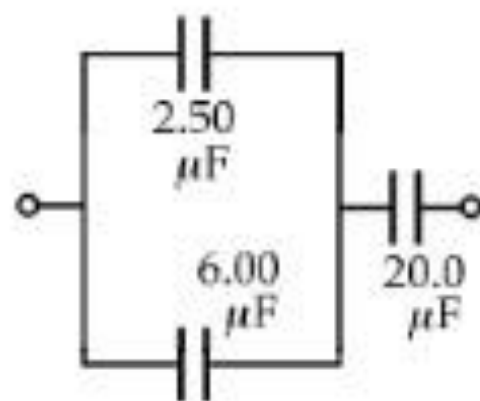
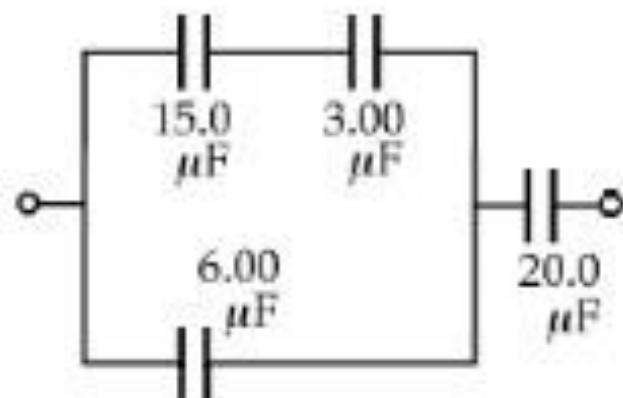

FIG. P26.21

31. (a) A 3.00- μF capacitor is connected to a 12.0-V battery. How much energy is stored in the capacitor? (b) If the capacitor had been connected to a 6.00-V battery, how much energy would have been stored?

$$(a) \quad U = \frac{1}{2}C(\Delta V)^2 = \frac{1}{2}(3.00 \mu\text{F})(12.0 \text{ V})^2 = \boxed{216 \mu\text{J}}$$

$$(b) \quad U = \frac{1}{2}C(\Delta V)^2 = \frac{1}{2}(3.00 \mu\text{F})(6.00 \text{ V})^2 = \boxed{54.0 \mu\text{J}}$$

36. A uniform electric field $E = 3\,000\text{ V/m}$ exists within a certain region. What volume of space contains an energy equal to $1.00 \times 10^{-7}\text{ J}$? Express your answer in cubic meters and in liters.

$$u = \frac{U}{V} = \frac{1}{2} \epsilon_0 E^2$$

$$\frac{1.00 \times 10^{-7}}{V} = \frac{1}{2} (8.85 \times 10^{-12}) (3\,000)^2$$

$$V = \boxed{2.51 \times 10^{-3} \text{ m}^3} = (2.51 \times 10^{-3} \text{ m}^3) \left(\frac{1\,000 \text{ L}}{\text{m}^3} \right) = \boxed{2.51 \text{ L}}$$

54. For the system of capacitors shown in Figure P26.54, find (a) the equivalent capacitance of the system, (b) the potential across each capacitor, (c) the charge on each capacitor, and (d) the total energy stored by the group.

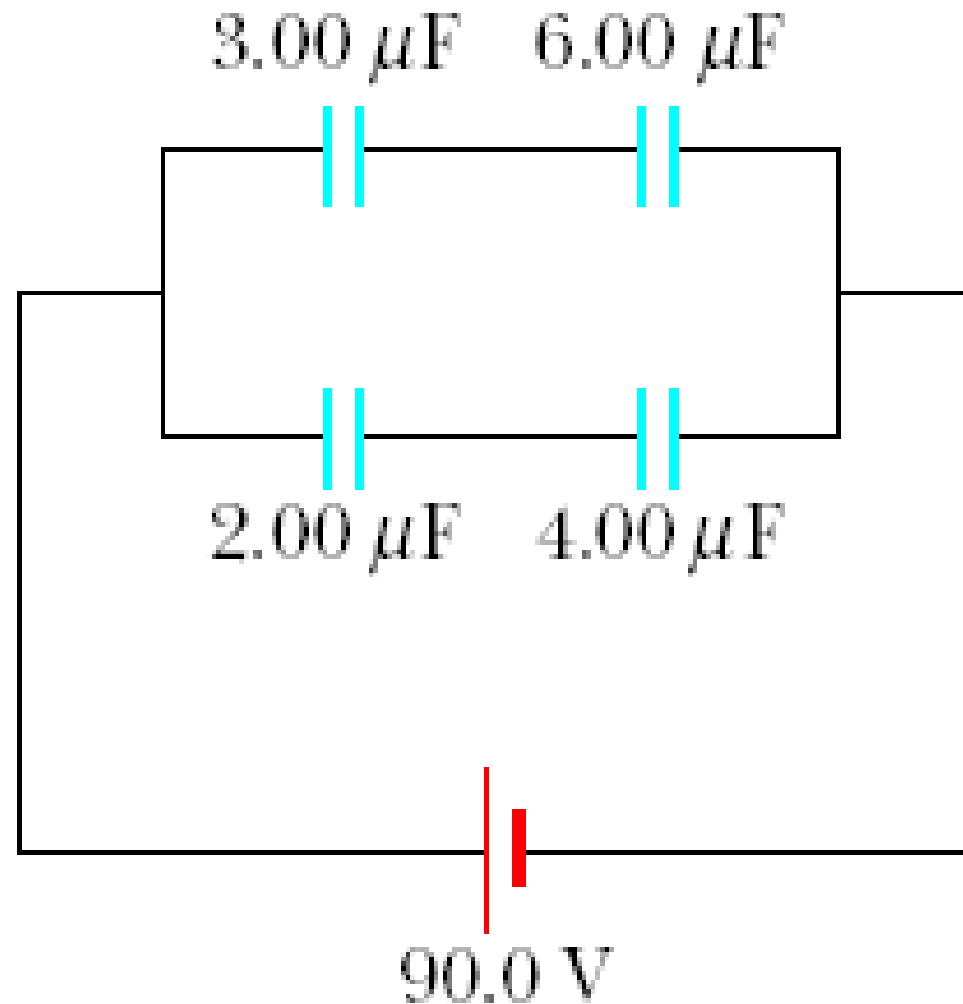

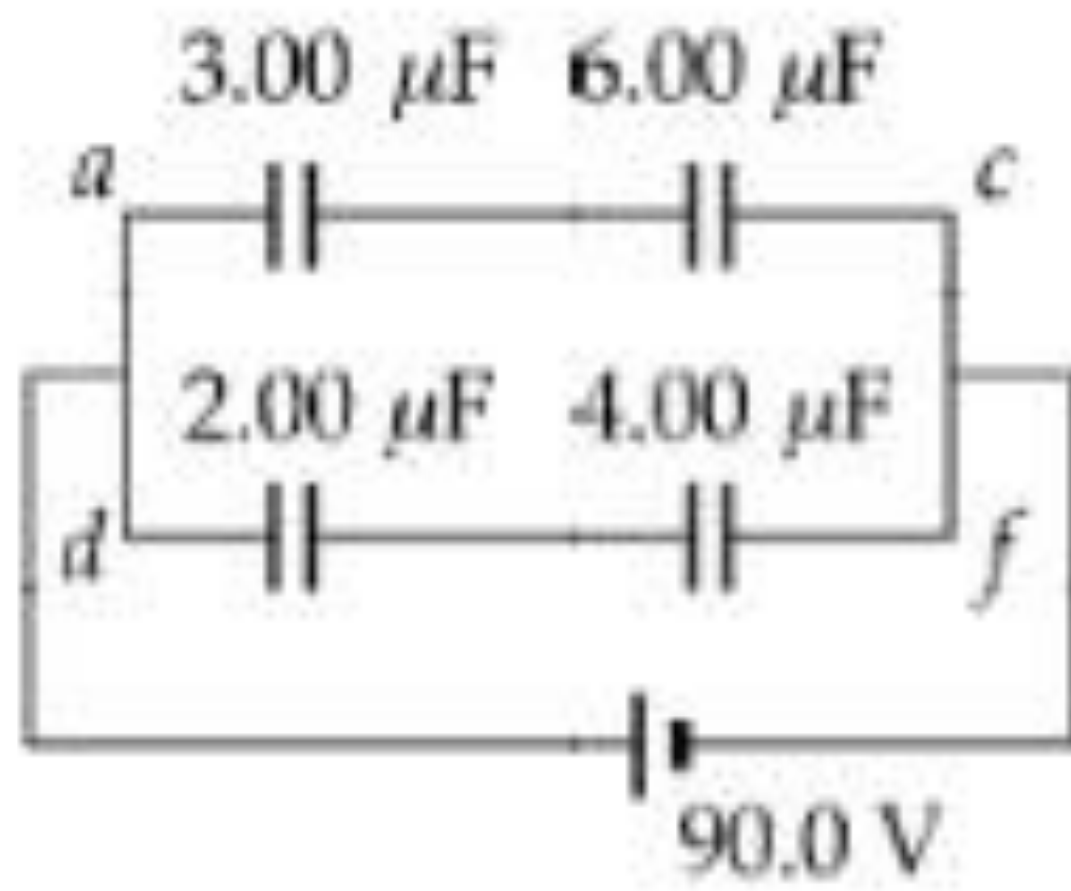

$$(a) \quad C = \left[\frac{1}{3.00} + \frac{1}{6.00} \right]^{-1} + \left[\frac{1}{2.00} + \frac{1}{4.00} \right]^{-1} = \boxed{3.33 \mu\text{F}}$$

$$(c) \quad Q_{ac} = C_{ac}(\Delta V_{ac}) = (2.00 \mu\text{F})(90.0 \text{ V}) = 180 \mu\text{C}$$

$$\text{Therefore, } Q_3 = Q_6 = \boxed{180 \mu\text{C}}$$

$$Q_{df} = C_{df}(\Delta V_{df}) = (1.33 \mu\text{F})(90.0 \text{ V}) = \boxed{120 \mu\text{C}}$$

$$(b) \quad \Delta V_3 = \frac{Q_3}{C_3} = \frac{180 \mu\text{C}}{3.00 \mu\text{F}} = \boxed{60.0 \text{ V}}$$

$$\Delta V_6 = \frac{Q_6}{C_6} = \frac{180 \mu\text{C}}{6.00 \mu\text{F}} = \boxed{30.0 \text{ V}}$$

$$\Delta V_2 = \frac{Q_2}{C_2} = \frac{120 \mu\text{C}}{2.00 \mu\text{F}} = \boxed{60.0 \text{ V}}$$

$$\Delta V_4 = \frac{Q_4}{C_4} = \frac{120 \mu\text{C}}{4.00 \mu\text{F}} = \boxed{30.0 \text{ V}}$$

$$(d) \quad U_T = \frac{1}{2} C_{eq} (\Delta V)^2 = \frac{1}{2} (3.33 \times 10^{-6}) (90.0 \text{ V})^2 = \boxed{13.4 \text{ mJ}}$$