

SE 464

**Introduction to
Digital Photogrammetry**

Introduction

- Digital photogrammetry is a generic description of a new form of photogrammetry based on digital (softcopy) images, as distinct from conventional photogrammetry, based on film (hardcopy) images.
- The projective geometry that is the basis of photogrammetry is the same whether it is applied to analog or digital images.
- The use of digital images offers distinct advantages in processing and automation.
- Digital photogrammetry came as a third or fourth generation of photogrammetry.

Development of photogrammetry

- Analog photogrammetry
 - A three dimensional stereomodel is reconstructed from two metric photographs.
 - The scaled and oriented model is plotted graphically on a map sheet.
 - There is no computer support.

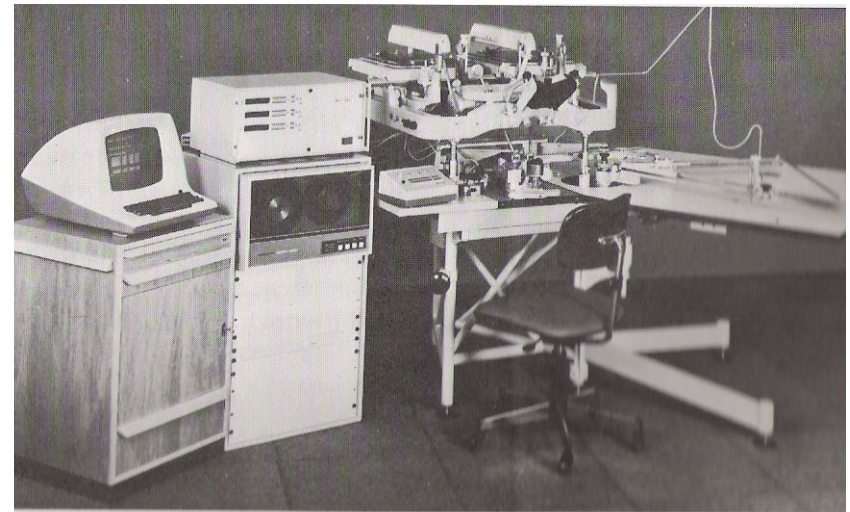

Figure 12-16. Kern PG2 stereoplotting instrument. Courtesy of Kern Instruments, Inc.

Development of photogrammetry

■ Numerical Photogrammetry

- An analogue instrument is equipped with encoders and counters on the x, y, z axes of the stereomodel.
- Coordinates are stored for later computation or fed directly into a computer.
- Computer aided mapping has been developed with varying degrees of interaction between computer, instrument and operator.

■ Analytical photogrammetry

- Image coordinates and parallaxes are measured in a stereocomparator and the geometry of the object is reconstructed in a computer.
- the setting of the measuring marks can be controlled by a computer program, by the operator or in interaction between them.
- The degree of computerization is very high, but human operator is still needed for the stereoscopic setting of the measuring mark



FIGURE 12-18
Leica SD3000 analytical plotter. (Courtesy LH Systems, LLC.)

■ Digital photogrammetry

- The images are stored digitally in a computer.
- The data can be acquired by digitization of photographs or from digital output from other sensing techniques.
- Images are presented on screens at workstations connected to the computer.
- Human stereoscopic vision is replaced by matching algorithms for different perspective of the image pair.
- Theoretically computer does everything.

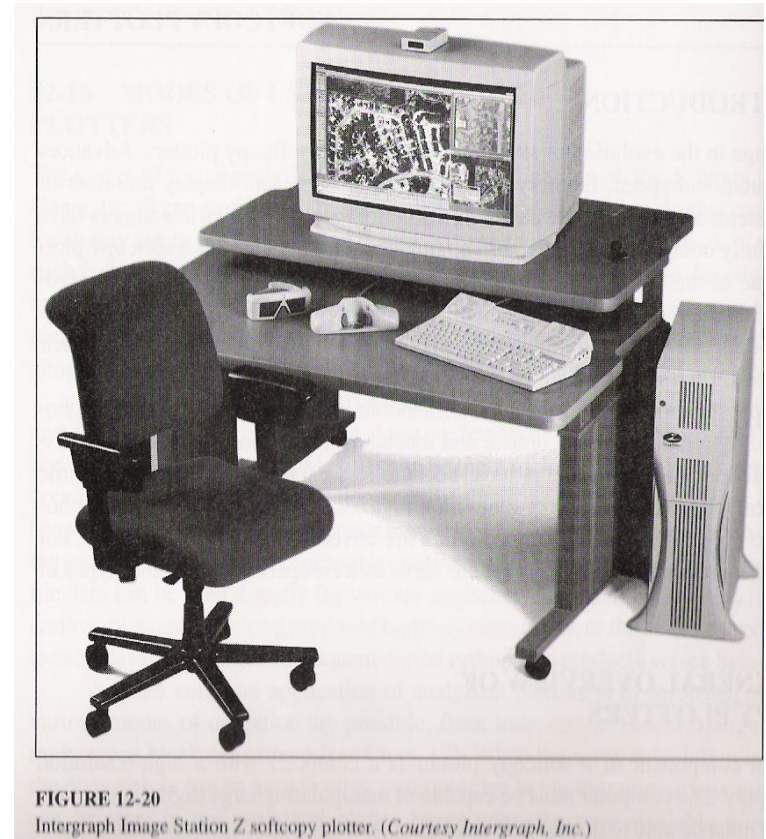

FIGURE 12-20
Intergraph Image Station Z softcopy plotter. (Courtesy Intergraph, Inc.)

Why digital?

- Some advantages of using digital images are:
 - Images can be displayed and measured on standard computer display devices (no optical/mechanical requirements)
 - Measurement systems are stable and need no calibration
 - Images enhancement can be applied
 - Automation can be applied
 - Operation can be carried out in real time, or near real time.

Factors contributed to the development of digital photogrammetry

- Analytical photogrammetry
 - The analytical plotter was invented by Helava in 1957
 - Most of the photogrammetric processes was computerized
- Orthophoto generation
 - There was a high demand for digital orthophotos
- GIS interface
 - More digital collection devices
 - GIS deals with digital data (maps, orthophotos, DEM)

Factors contributed to the development of digital photogrammetry

- The use of digital stereo imagery
 - After SPOT earth observation sat. became more appealing because:
 - digital imagery
 - stereoscopic capabilities
 - high spatial resolution
 - attitude stability
 - large base-to-height ratio
- Advances in computer technologies
- Reliable and easy to use cheap digital cameras

Advantages of Digital Photogrammetry

- Integrate image and map data in raster and vector formats
- Edit data that has been collected
- Implement image-processing functions such as contrast enhancement, edge sharpening, change detection, vector on raster overlay
- Interface with GIS software for overlay analysis and modeling applications
- Automatically generate Digital Elevation Models (DEMs) and display data sets in both perspective and plan view
- Produce digital orthophotos.

Analog vs. Digital

- The word “Digital” or “Softcopy” distinguishes this new development in terms of two issues.
 - It deals with representation of information that is digital imagery replacing conventional film photography.
 - This concern with the host environment, in this case replacing plotting machined by computer.

Analog vs. Digital

Analog	Digital
Photo	image
floating mark	cursor
Handwheel	mouse
photo stage	computer monitor
Operator does most of the work	computer does most of the work
Stereoplotter	photogrammetric workstation

- **Digital photogrammetry =
photogrammetry + digital image processing**

- “With digital cameras and digital image processing, photogrammetry will operate in a completely different environment, characterized by different equipment, techniques, skills, and by a different way of thinking.”

Ackerman 1991

Definition of digital photogrammetric image







- Analog images or photos are not directly amenable to computer analysis.
- Since computers work with numerical rather than pictorial data, a photograph must be converted into numerical form before processing.
- A digital image consists of a two dimensional matrix G with elements $g(i,j)$.
- Each element is called a pixel (artificial word from picture element)
- The row index i runs from 1 to M in steps of 1, i.e. $i=1(1)M$.
- The corresponding index for the columns is: $j=1(1)N$

$$g(x, y) = \begin{bmatrix} g(1,1) & g(1,2) & \cdots & g(1,N) \\ \vdots & \vdots & \vdots & \vdots \\ g(M,1) & g(M,2) & \cdots & g(M,N) \end{bmatrix}$$

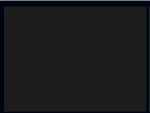
Definition of digital photogrammetric image

- The pixel $g(i,j)$ is the information carriers and it represents a density value or a gray level corresponding to a point in the analogue photograph.
- A number of terms are used to describe the quantity which is measured
 - **Intensity:** the brightness of the image at a particular point measured in volts or lumens. The intensity at a point x,y is represented by $g(x,y)$
 - **Gray Values:** a recorded value of g over a gray scale
 - **Density:** this is the term used to express the degree of darkness on a developed film. It is recorded digitally as gray values.

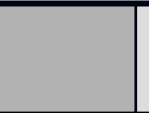
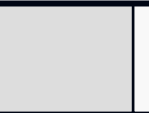
- The value of a pixel depends upon the type of recording instrument and on the computer in use.
- The mostly widely used ranges of values at present runs from zero to 255.
- The information contained in 256 different values can be stored in eight bits (2^8 bit combination) and a group of eight bits is treated as one unit, a byte, in most modern computer.
- For black and white pictures, the pixel values represent the gray values on densities (usually with black as 0 and white as 255).

							
0	36	72	108	144	180	216	255

Coordinate System Convention

- The origin of the coordinate system is defined in the upper left corner of the digital image matrix. The coordinates of pixel $g(i,j)$ located at the row i and column j of the digital image can be found as

$$x(i,j) = x_o + D_x \cdot j$$

$$y(i,j) = y_o + D_y \cdot i$$

- This relation converts the image coordinates (in pixels) to photo coordinates (in mm)

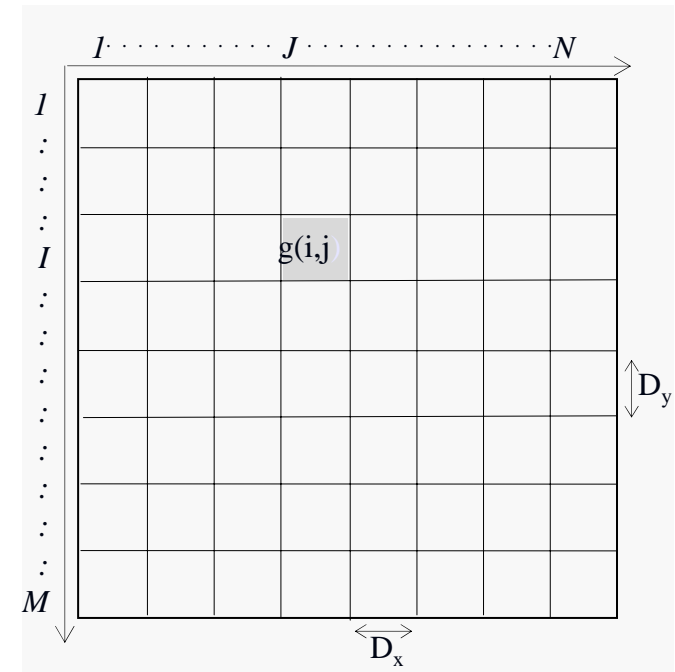

Photographic Resolution

- *Resolution* is a measure of the ability of an optical system to distinguish between signals that are spatially near or spectrally similar.
- Or it is a measure of the sharpness of the image, usually expressed in dots per inch (dpi).
- A higher resolution gives a sharper image.
- *Dots per inch (dpi)* in a digital image is the number of pixels per inch in both the vertical and horizontal direction when viewed at the same scale as the original analog image.

- Pixels
 - Picture element: the smallest discrete element that makes up an image.
 - Smallest unit of information in a scanned image.
- Resolution is influenced by:
 - resolving power of the film
 - camera lens used
 - any uncompensated image motion during exposure
 - the condition of the film processing
 - etc.

Types of resolution

- **Spectral resolution** refers to the dimension and number of specific wavelength intervals in the electromagnetic spectrum to which a sensor is sensitive.
 - The size of the interval or band may be
 - large (i.e. coarse) as with panchromatic black and white aerial photography (0.4 to 0.7 μm), or
 - relatively small (i.e. fine) as with band 3 of the landsat 5 thematic mapper sensor system (0.63 to 0.69 μm)

EM Radiation Wavebands: Final Remarks

Advantages vs Disadvantages

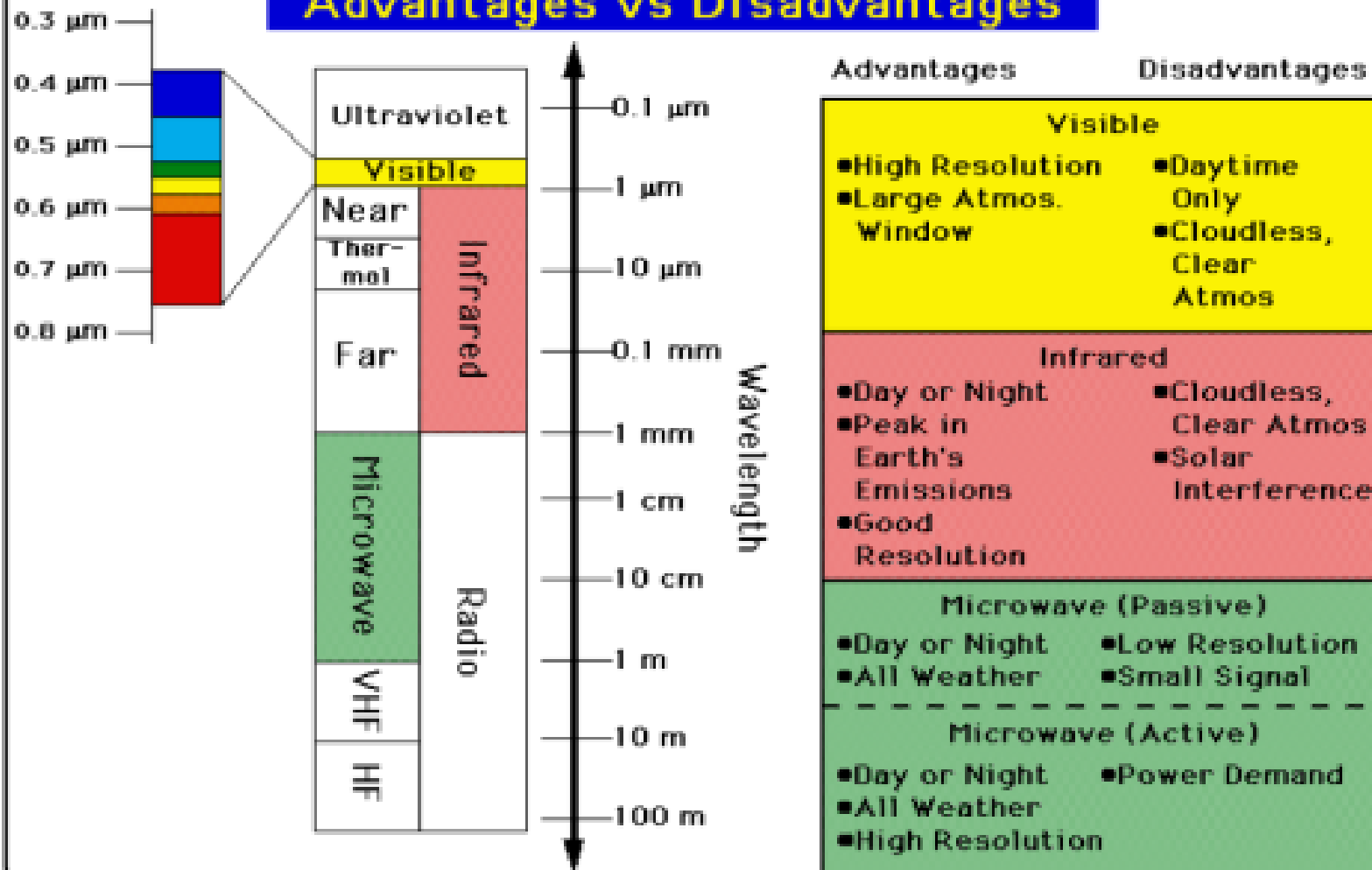

- **Spatial resolution** is a measure of the smallest angular or linear separation between objects that can be resolved by a sensor
- Aerial photography spatial resolution is normally measured as the number of resolvable line pairs per millimeter on the image.

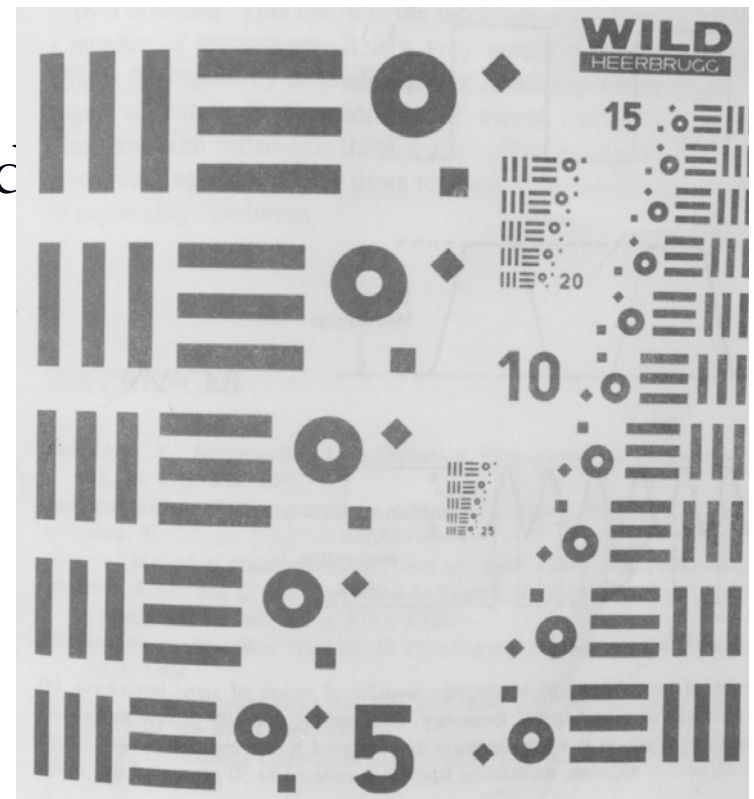

- Digital images are often described in term of their pixel size, or in term of instantaneous-field of view (IFOV).
- It is the angle determined by the pixel size and the focal length.
- For other sensor systems it is simply the dimension of the ground projected instantaneous-field of view (IFOV) of the sensor system.

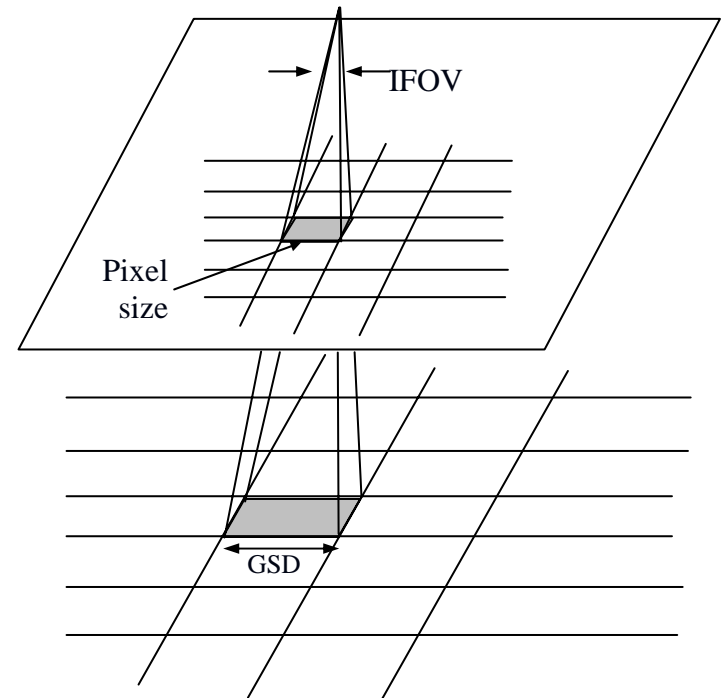

- Another measured related to pixel size is the ground sample distance (GSD).
- GSD is the projection of the pixel size onto the ground plane.
- Example: pixel size= 0.025 mm, f=150 mm, H= 6000m, find IFOV and GSD at Nadir.

$$\text{IFOV} = 2 \tan^{-1}\left(\frac{0.025/2}{150}\right) = 0.000166 \text{ rad}$$

$$\text{GSD} = \text{IFOV} (6000) = 1 \text{ m}$$

Spatial resolution and geometric accuracy

- What values should be used to faithfully represent the diapositive obtained with modern camera?
- The theoretical limitation are given by the sampling theorem.
- The sampling theorem states that the smallest pixel size should be less than half of the highest frequency of the continuous function
- A useful rule is that in order to detect a feature, the spatial resolution of the sensor system should be less than half the size of the feature measured in its smallest dimension.

Spatial resolution and geometric accuracy

- Assume a photograph resolution 70 lp/mm. To represent the photograph by the digital image, a pixel size of about 7 μm is required.
- **Accuracy question:** Do we sacrifice accuracy for the benefit of less storage and processing time?
- It is important to differentiate between resolution (pixel size) and accuracy.
- The pixel size is derived by the interpretability of small features and to lesser degree by accuracy considerations.

Image scale and Ground Sample Distance

- Scale has been a fundamental measure of utility and quality for many decades with hardcopy imagery.
- However, a digital image file does not have a scale per se;
- It can be printed and displayed at many different scales.
- Scale is a function of the device and processing used to display or print the file
- Users have been used to assigning a level of photo interpretability based on scale.
- With digital imagery, ground sample distance (GSD) provides a more appropriate metric.

Spatial resolution and geometric accuracy

- Digital imagery may easily be resampled to alter the ground sample distance on the fly for screen display, or as a step toward creating a new permanent image file derived from the original.
- Collection, product, and display GSDs can be very different for the imagery from the same source.
- Camera scale = focal length / height AGL

$$\text{collection GSD} = (\text{array element size}) \frac{\text{height AGL}}{\text{focal length}}$$

Spatial resolution and geometric accuracy

- For example, $f = 28\text{mm}$, altitude = 1800 AGL → scale = 1:65,000
- If the image in the focal plane is sensed by a charge-couple device (CCD) array, then

$$\text{collection GSD} = (\text{array element size}) \frac{\text{height AGL}}{\text{focal length}}$$

- GSD is simply the linear dimension of a single pixel on the ground.
- Example, if the array element size = 0.009 mm → GSD = 0.6m.

Spatial resolution and geometric accuracy

- Digital imagery is rarely, if ever, printed or displayed at the camera scale itself.
- That is usually much too small for display digital printers and displays.
- Example, suppose the CCD array is 3000 pixel wide, If one prints an image on a 300 dpi → it will be about 10 inches wide. → pixel size = 0.085 mm
- Printed scale = printer pixel size / collection GSD = 1:7000
- The display scale = display pixel size / collection GSD
- Consider display on a screen with pixel size of 0.3 mm
- Display scale = 1:2000 for 1:1 display of image pixels to screen pixels

Spatial resolution and geometric accuracy

- The product GSD is the real world size of a pixel in a digital image product after all rectification and resampling procedures have occurred.
- It should be clear that scale does not tell the whole story for digital imagery
- And neither does product GSD – unless the collection GSD of the imagery used to make the product equals or exceeds the product GSD itself.
- GSD clearly affects product quality and utility.
- A smaller product GSD leads to a larger digital image

Types of resolution

- **Radiometric resolution** defines the sensitivity of a detector to differences in signal strength as it records the radiant flux reflected or emitted from the terrain.
- It is the number of bits per gray level to register an image.
- One byte = 256 gray shades is more than sufficient to represent the gray shades of b/w photograph.
- Usually, the human operator cannot discriminate more than 50 gray shades.

Statistical Representation of Digital Images

- A digital image is considered a discrete approximation of a continuous function.
- According to statistical approach, a digital image is a set of random variables which are the gray values of each pixel.
- The quality and the character of the image can be expressed by statistical properties of the gray values

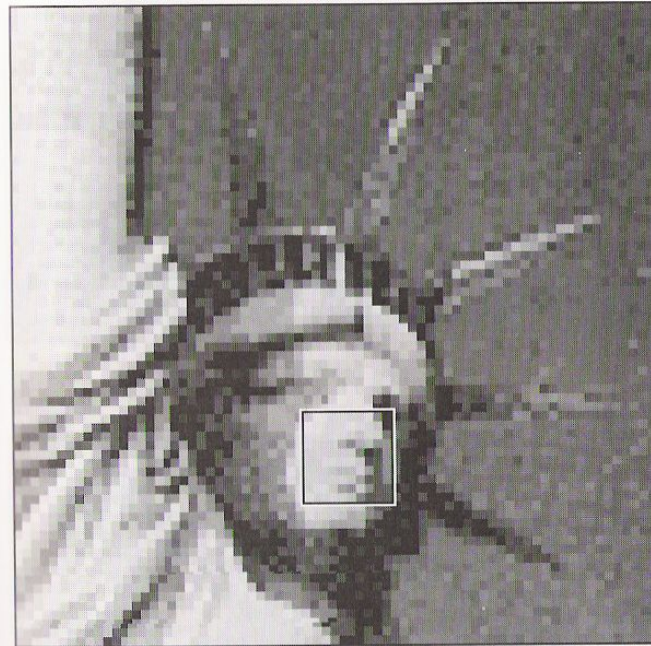

(a)

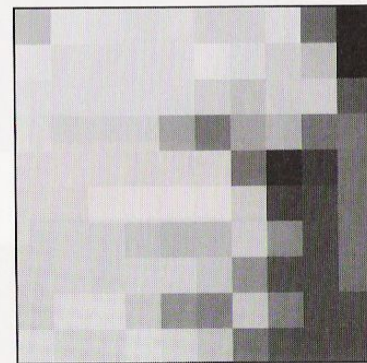

(b)

190	237	234	223	227	220	219	231	115	2
237	227	223	228	229	237	229	219	190	1
231	227	223	227	229	219	196	216	217	96
229	218	220	219	160	120	164	183	127	136
219	218	219	213	214	210	113	2	54	127
217	213	223	227	223	222	199	54	70	128
219	217	207	196	183	187	207	149	74	126
217	216	210	218	217	203	145	70	73	127
207	223	227	203	145	127	200	136	75	80
227	219	218	223	219	190	115	70	71	74

Statistical Representation of Digital Images

- The **mean** or average of gray value m of an image is the average of the gray values of all the image pixels.
- For an image $f(x,y)$ of N rows and M columns the mean is

$$m = \frac{1}{M \cdot N} \sum_{x=1}^N \sum_{y=1}^M f(x, y)$$

- The value of the mean shows whether the image is light or dark.
- For images of 256 discrete gray values an m value higher than 128 indicates a light image. Lower m values correspond to dark images.

Statistical Representation of Digital Images

- The **variance** (var) of image

$$\text{var} = \frac{1}{M \cdot N} \cdot \sum_{x=1}^N \sum_{y=1}^M (f(x, y) - m)^2$$

- Provide information about its contrast.
- Small variance values indicate poor contrast and vice versa.
- A uniform image where all pixels have gray value of 127 will have mean 127 and variance 0.

Statistical Representation of Digital Images

- The gray level distribution in the image can be expressed by the **histogram**.
- It is a plot of the percentage of occurrence of the gray value g_i versus the gray value g_i .
- The percentage ($p(g_i)$) of pixels with gray value g_i is:

$$p(g_i) = \frac{a_{g_i}}{n}$$

where n is the total number of pixels in the image and a_{g_i} the number of the pixels with gray value g_i

Statistical Representation of Digital Images

4	4	2	2	3	0	1	1	2	4
7	2	3	1	3	5	2	3	3	5
0	7	3	4	0	2	3	3	3	2
1	5	4	1	3	4	2	4	1	0
5	4	1	2	3	7	6	5	1	3
5	0	1	4	7	6	7	0	4	4
2	5	7	3	1	4	5	3	0	1
2	0	2	3	2	6	3	7	3	6
0	5	4	0	5	6	2	6	6	7
5	4	6	4	3	2	1	2	1	6

0	1	2	3	4	5	6	7
10	13	16	18	15	11	9	8

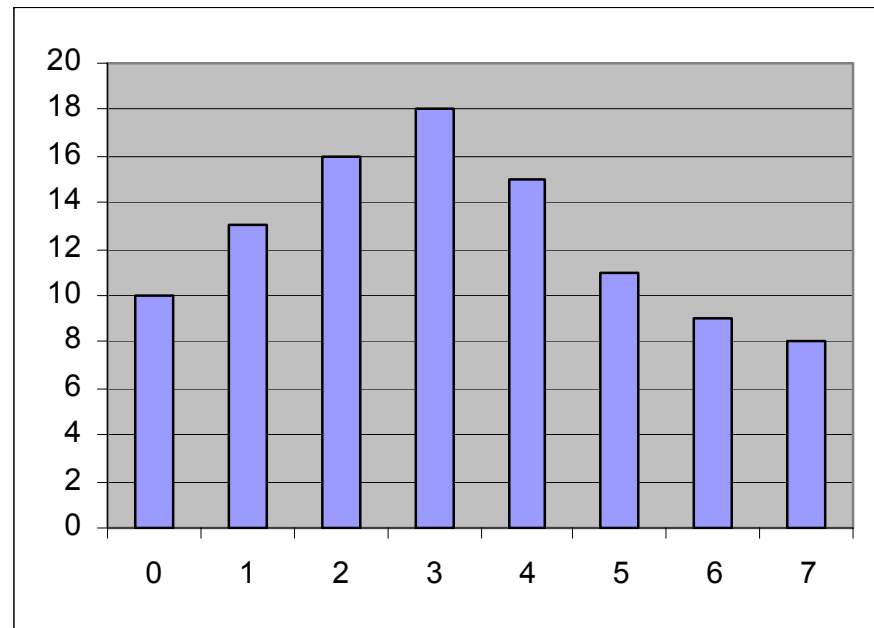

Statistical Representation of Digital Images

- **Entropy** is a measure of the information content of an image
- It expresses the number of bits necessary for the representation of the information of an image.
- Entropy is a global measure of the correlation of gray levels of neighboring pixels
- It provides valuable measure of the data transmission and storage.
- For an image of 256 distinct values, entropy (H) is:

$$H = -\sum_{i=0}^{255} p(g_i) \cdot \log_2 p(g_i) \quad \text{where } p(g_i) \text{ is as defined above.}$$

- For binary image with $p(g_0) = p(g_1) = 0.5$

$$H_b = -[p(g_0) \cdot \log_2 p(g_0) + p(g_1) \cdot \log_2 p(g_1)] = 1$$

Digital Image Acquisition

- In digital photogrammetry, it is necessary to have the imagery in a digital format.
- Digitization (scanning) is the process of converting a two-dimensional continuous function (in this case the analog image) into digital (discrete) form.
- Since continuous tone images have continuity both:
 - in position (i.e. a plane with continuous variation of x, y) and
 - in tone (i.e. the continuous gray level variation,
- therefore, to digitize it is necessary to discretize these two aspects of the image, namely the position and the density.

- Digitization consists of :
 - Sampling the gray level in an analog image at an $M \times N$ matrix of points
 - Quantizing the continuous gray levels at the sampled points into Q uniform intervals
- The finer the sampling and the quantization, the better the approximation of the original image

Sampling

- For generating a digital image, the pixels are collected at intervals D_x and D_y .
- Usually $D_x=D_y=P$, where P is normally a constant called the sampling interval.
- In practice, each pixel is often assumed to represent an area equal to $D_x \times D_y$
- The choice of the sampling interval (i.e. the pixel size) plays an essential role in the transformation of the information from analog to digital form.
- If the sampling interval is **too long** (resulting in a large pixel size), some image resolution (image information) is lost. → The image is under-sampled.
- If the sampling interval is **too short**. (resulting in a small pixel size), too many digital samples. → The image is over-sampled.

Sampling



(a)



(b)

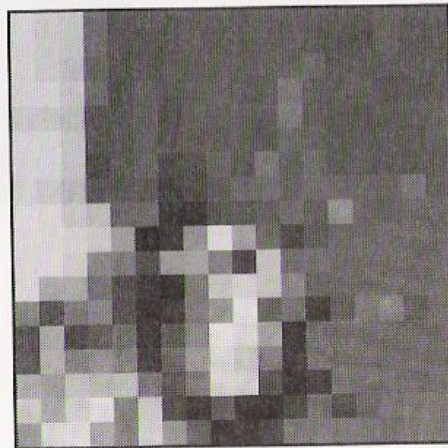

(c)

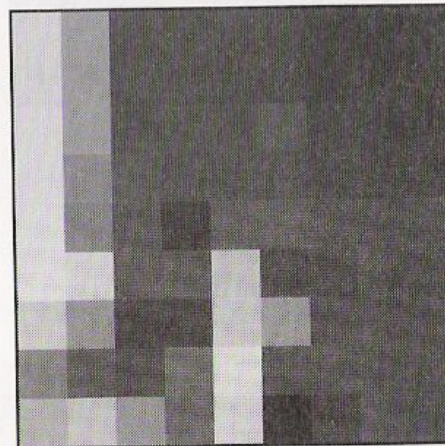

(d)

Quantization

- The gray levels of a continuous tone image must be divided into discrete values in a digital image.
- Each quantized pixel is represented by a binary word (2^b where b is the word length in bits).
- When an image is quantized with an inadequate number of bits, the image will have a degradation in its gray levels.
- If an image is quantized with a larger number of bits than required, there will be some unnecessary density values which appear as noise.

Quantization

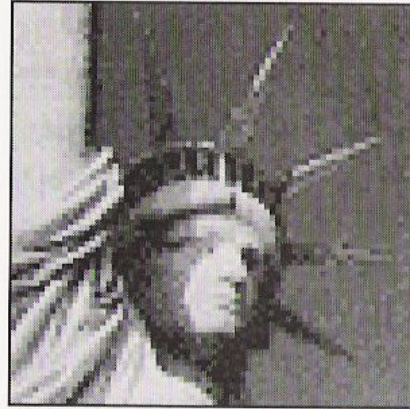

(a)

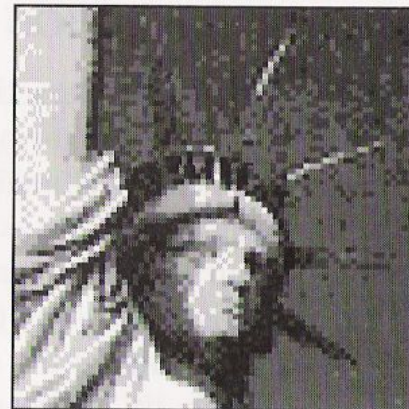

(b)



(c)



(d)

Digital Image Acquisition Systems

- There exist two fundamental mechanisms for accomplishing this task:
 - Acquire the images in analog format (e.g. an aerial photograph), and then digitize it.
 - Acquire the images in a digital format in the beginning, such as a CDD array cameras.



Photogrammetric Scanner



Digital Aerial Camera: DMCTM

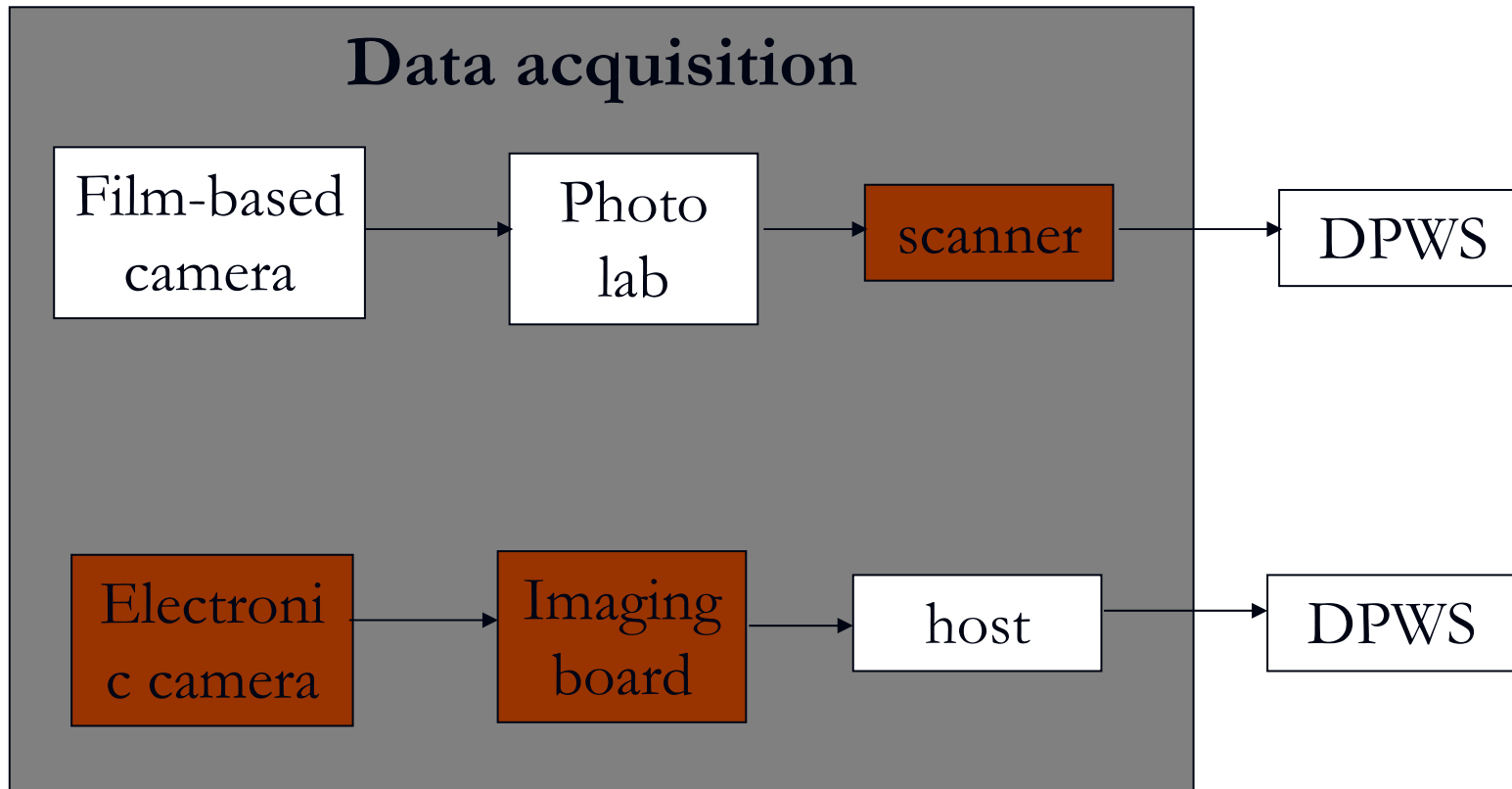

Scanners

- The photogrammetric scanner is currently a necessary component of large-scale digital mapping systems.
- Currently conventional film-based aerial cameras are the most successful means to capture image data at large data because of the following characteristics:
 - A large format covers a larger area of terrain for any given scale.
 - Currently there is a world-wide availability of survey (film) cameras, which are suitable for existing mapping services
 - Conventional film data is compatible with existing mapping equipment
 - Resistance to changing technologies.
 - The high information content
 - Strong geometry
 - Large dynamic range for radiometry
 - Compact storage

Scanners

- Current digital sensors suffer from some combination of size limitations, geometric weakness, and dynamic range limitations.
- Thus, at least for the foreseeable future, film will continue to be the medium of choice for large-scale mapping.
- However, the flexibility and economics of digital image manipulation for the actual mapping process dictate that film image to be converted to digital film.
- Steps of analog-to-digital data capture are:
 - Primary data acquisition on 23 cm² film
 - Film processing via roller transport machines
 - Film scanning with variable scanning apertures
 - Computer processing and operation.

Architectures of film scanners

■ Rotating Drum

- holding the film transparency with photomultiplier tube (PMT) performing the actual intensity detection
- The film transparency is mounted on a glass-rotating drum so that it forms a portion of the drum's circumference.
- The light source is situated in the interior of the drum.
- The x-coordinate scanning motion is provided by the rotation of the drum
- The y-coordinate is obtained by the incremental translation of the source-receiver optics after each drum revolution.

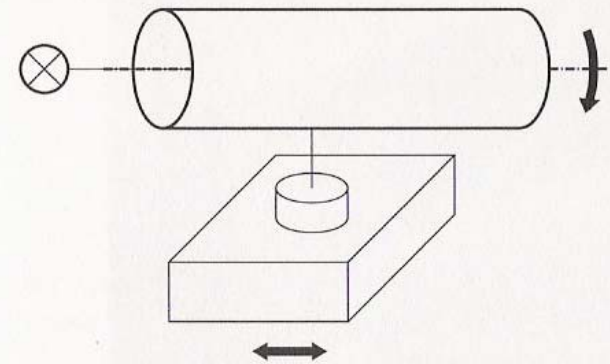

(a)

Architectures of film scanners

■ Rotating drum

- It offers the largest dynamic range for capturing imagery.
- Mounting the transparency on a drum requires physically cutting apart the film roll, a disadvantage for automation of film roll scanning.
- Maintaining good geometry requires careful attention to the mechanical and electronic detail of the scanning motion and the detection timing.
- Pixel size is determined by a mask and by the translation speed of the detector moving along the drum.

Architectures of film scanners

- Flatbed stage (linear CCD array)
 - holding the film transparency with a linear CCD array scanning the image area
 - The linear array CCD scanner either moves a glass stage over the CCD array or moves the array over the stage.
 - The linear CCD are used in order to be able to scan at once with a set of 10,000 or 12,000 detectors, either on only one linear CCD, or while joining several shorter linear CCD.
 - Color can be captured by multiple passes with multiple filters or using three parallel linear CCD.

Architectures of film scanners

- Flatbed stage (area CCD array)
 - holding the film transparency with an area CCD array stepping and capturing a sequence of frames to cover the image area.
 - CCD matrix used has the order of 2,000 X 2,000 pixels.
 - There are much larger matrices, but they are very expensive and would not accelerate the process.
 - The mechanical displacement must permit an excellent connection between the individual pictures that will make up the whole image.

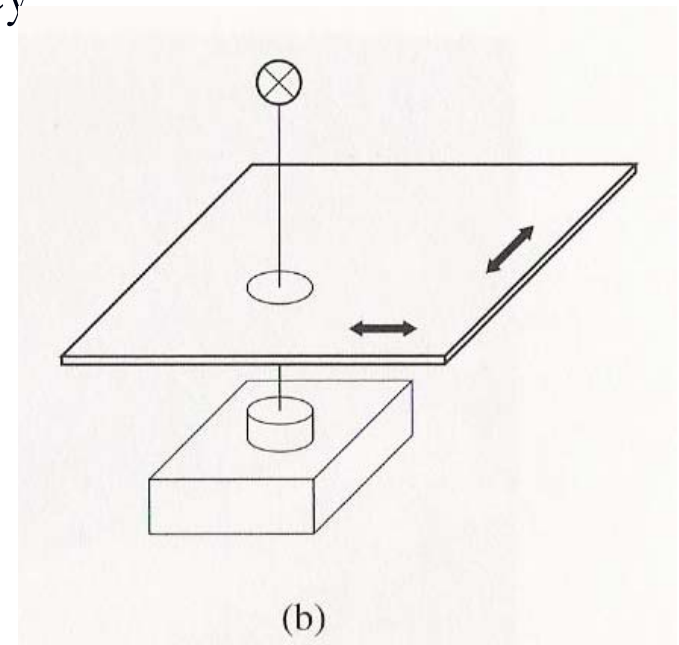

Size of the pixel

- The available pixel size are very variable (4μ - 300μ)
- Recommended sizes of pixel depend on the quality of the image to be digitized and on the photogrammetric work to be performed.
- A size of 25μ is satisfactory in most of the studies of photogrammetry.
- Smaller sizes (15μ) give gains in precision are very modest but at high cost in terms of computer complications.

Large A3 scanners

- Scanners to the format A3 are available on the market
- Capable of digitizing a whole aerial photograph
- Cheaper than the specialized devices for photogrammetrists. (around 50 times less)
- Active pixel size from 30μ to 40μ
- Using triple linear CCD with RGB filters, which permits a digitization in only one pass and therefore a good geometric homogeneity.
- 2 pixel geometric errors.
- They are used for certain photogrammetric studies nor requiring the maximal precision.

Scanner Errors

- All scanners have mechanical errors
- Errors caused by guide-rail imperfections cause:
- A non orthogonality between the object plane and camera lens axis that result in **pointing error**.
- Distance fluctuation between the image plane and object plane (**scaling error**).
- Distance fluctuation between the camera lens and object plane (**focusing error**)

Scanner Errors

- Motions are provided and regulated by a servo-motor system. **Motion errors** (too fast or slow) may be detected.
- If left uncorrected, these geometric errors (pointing, scaling, focusing and motion errors) produce observable artifacts (such as misaligned pixels)
- If the illumination system is uneven, or if the CCD-camera lens has excessive and uncorrected **vignetting (radiometric errors)**, the observable misalignment will be more pronounced, while the geometric error remain the same.
- Other errors such as **thermal dynamics-induced errors** and **mechanical vibrations** can also influence results.

Requirements of photogrammetric scanners

■ Geometry

- With current photographs, a level of precision of the order of $\pm 2 \mu\text{m}$ can be reached in aerotriangulation.
- This precision is also usually obtained with analytical plotters.
- Consequently, it is important to require the same precision for photographic scanners.

■ Image resolution:

- This parameter is decisively determined by the quality of the film used for aerial photographs and by the aerial camera.
- It seems appropriate to require a pixel size about $10 \times 10 \mu\text{m}$ for black and white.
- A pixel size of $15 \mu\text{m}$ might be sufficient for color.

Requirements of photogrammetric scanners

■ Image noise:

- The noise of photographic film is mainly defined by its granularity.
- The pixel size can be chosen small enough, allowing full benefit to be derived of the film resolution.

■ Color reproduction

- With the increase use of color photographs, it is important to be able to scan color photographs.

■ Format

- Allow the processing of aerial photographs 24 x 24 cm
- Paper or film photographs
- Processing roll film directly

Acquire digital images directly

Digital cameras

- It uses a camera body and lens but record image data with CCDs rather than film.
- Film records the reflected electromagnetic energy through silver halide crystals.
- Digital imaging devices use solid-state detectors to sense the energy.
- It builds up an electric charge proportional to the intensity of the incident light.
- The electric charge is subsequently amplified and converted from analog to digital form.
- A large number of CCDs can be combined on a silicon chip in a one-dimensional or two dimensional array.

Acquire digital images directly

Digital cameras

- The electrical signals generated by these detectors are stored digitally, typically using media such as computer disks.
- Images can be either black and white or color.
- The use of digital cameras provides several advantages:
 - rapid turnaround time (images are immediately available for viewing)
 - An inherently digital format (no scanning needed).

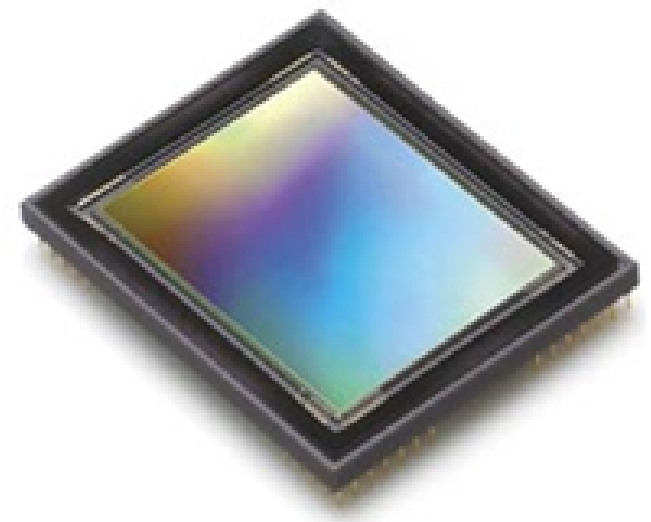

- Although the current resolution of digital imaging systems is very good, images are not as detailed as those imaged onto photographic film of similar format.
- Unlike film photographs, which have an almost infinite resolution, digital photos are limited by:
 - the amount of memory in the camera,
 - the optical resolution of the digitizing mechanism,
 - The resolution of the final output device.
- Even the best digital cameras connected to the best printers cannot produce film-quality photos

1. Digital Frame Cameras

- Similar to single-lens frame camera
- It consists of 2D array of CCD elements mounted on the focal plane of the camera.
- Two-dimensional array sizes of digital cameras typically range from 512 X 512 pixels to 2048 X 2048 pixels or even 4096X 4096 pixels.
- Current technology can produce chips with individual CCD elements approximately 5 to 15 μm in size.

- A 4096X 4096 array format will be from 20 to 60 mm square.
- Exposure times as short as 1/8000 sec are available.
- Acquisition of an image exposes all CCD elements simultaneously, thus producing the digital image.
- No mechanical movement
- The metric of the image is absolutely excellent, and even better than classic film cameras.(no development and drying => stretching)

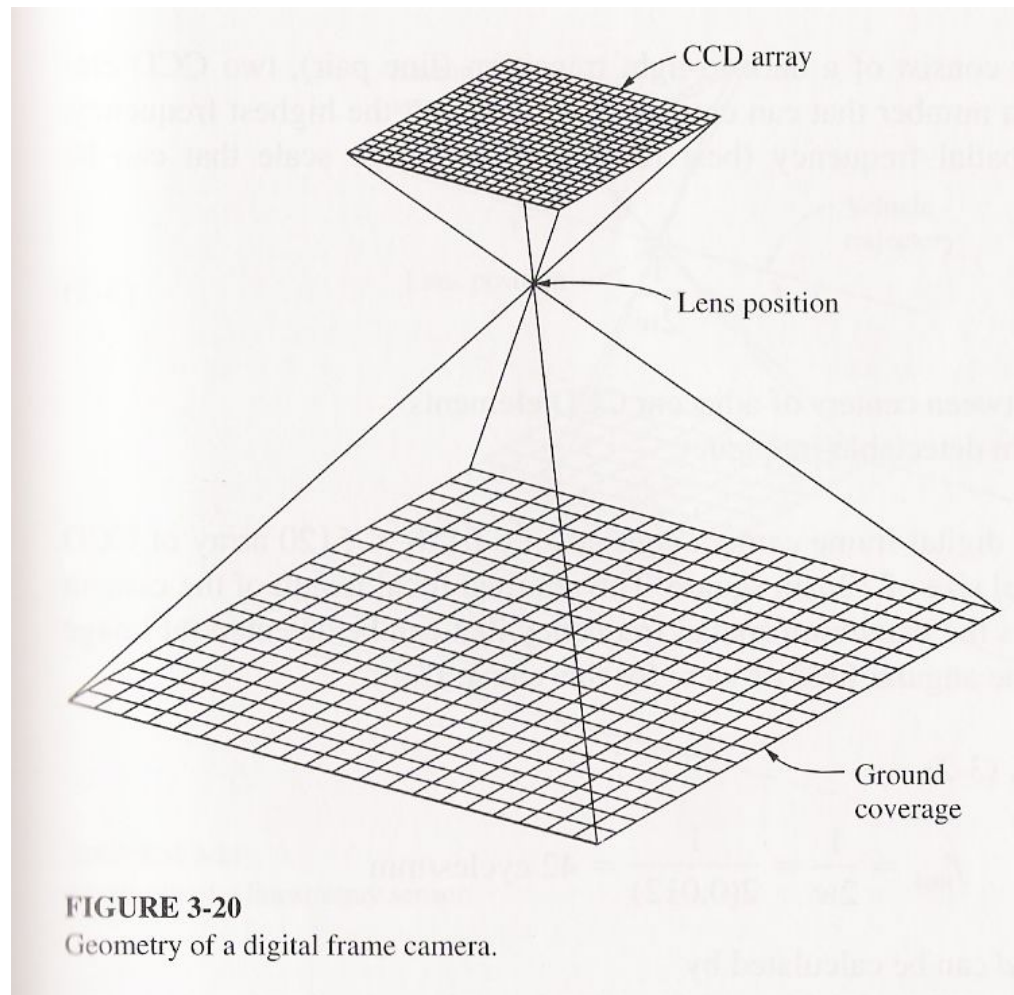

2. **Linear Array Sensors**

- A linear array consists of a strip of CCD elements mounted in the focal plane of a single-lens camera.
- A linear array sensor acquires an image by sweeping a line of detectors across the terrain and building up the image.
- At a particular instant, light rays from all points along a perpendicular to the flight direction pass through the center of the lens before reaching the CCD elements
- Number of pixels per line can reach 12000 pixel
- That produces a single row of the 2D image.
- The sensor proceeds in this fashion until the entire image is acquired.
- In photogrammetry, the image has to have stable geometry, sensor should travel smoothly => use satellite is used.

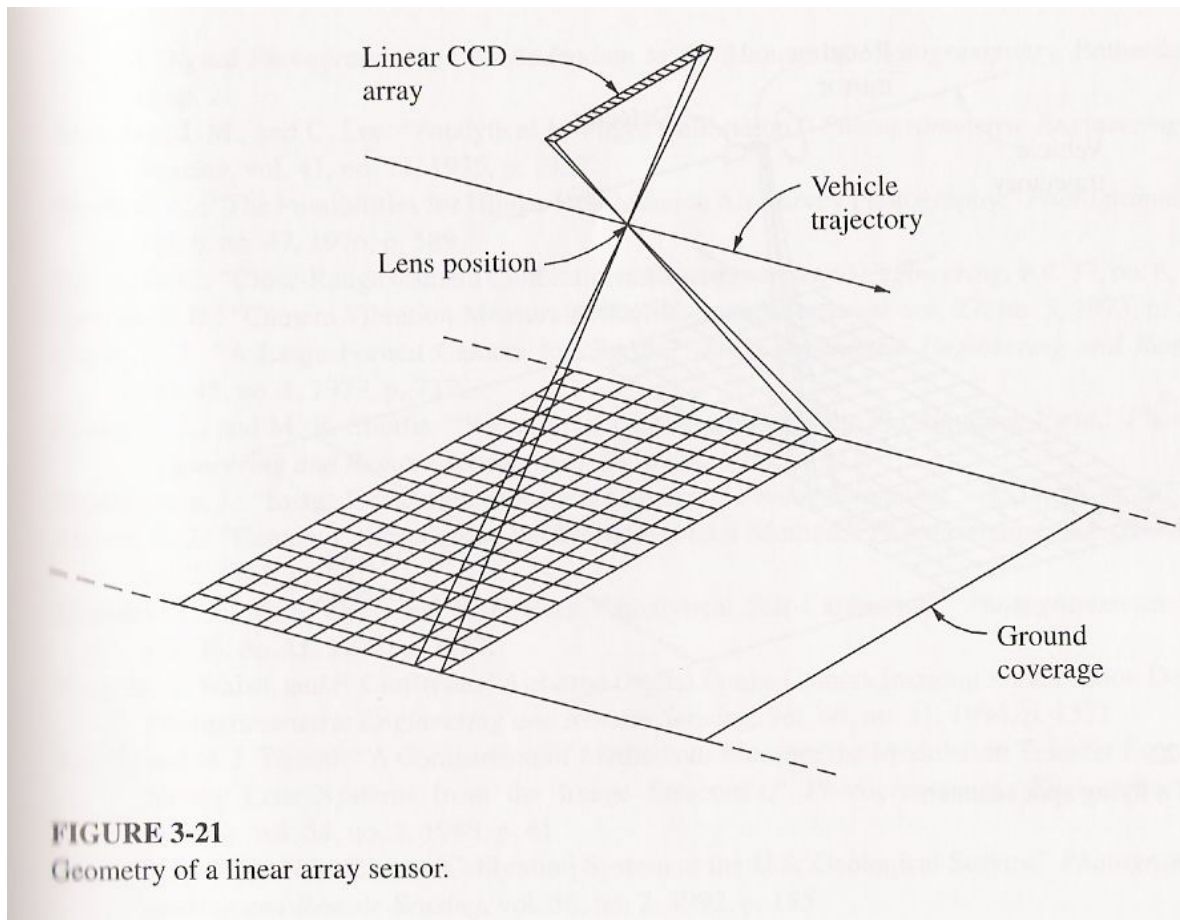

3. **Flight Spot scanners**

- This device uses a mirror which rotates in a direction around the flight direction.
- In this case, the image is formed one pixel at a time
- The scan lines are skewed somewhat due to the forward motion of the vehicle during scanning.
- This effect requires that extensive geometric corrections be applied to the raw image to make it suitable for photogrammetric use.
- They are seldom used for photogrammetric mapping, and then only for low-accuracy work.

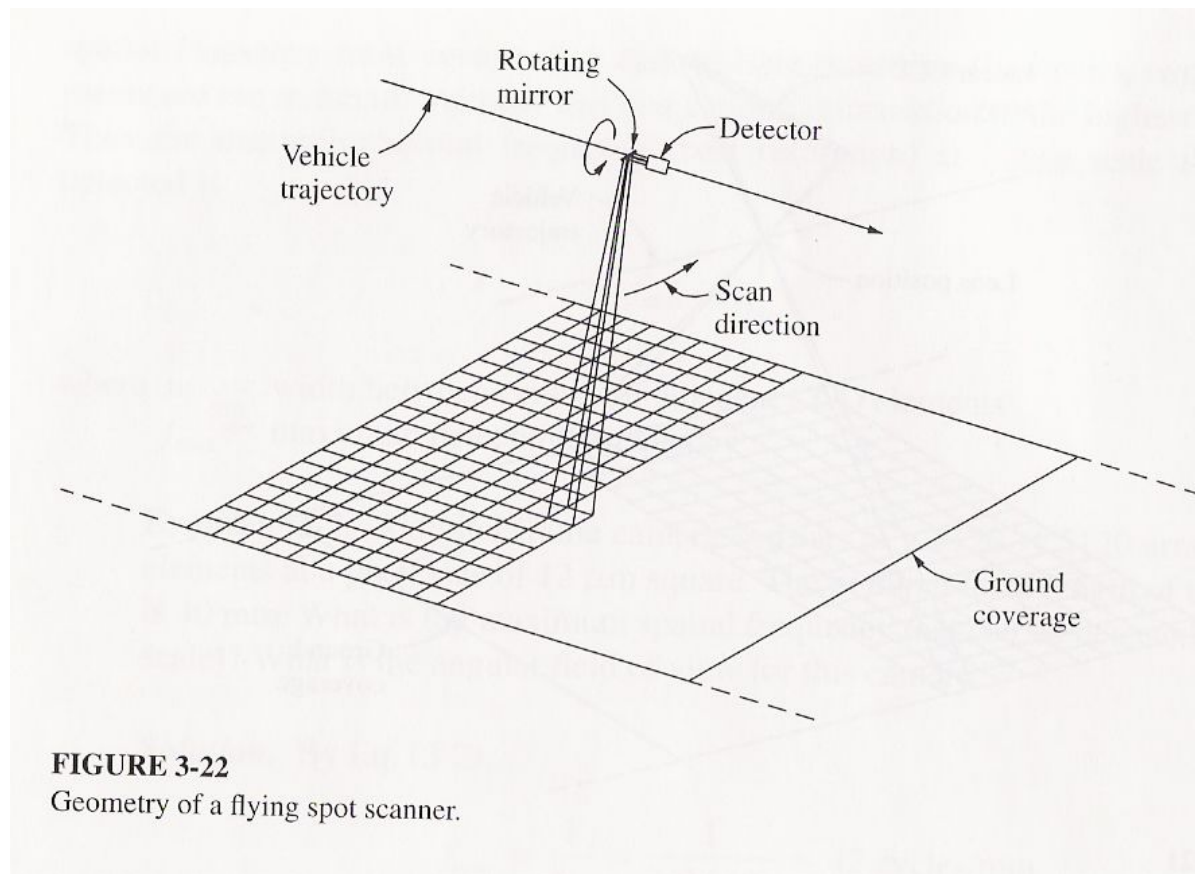

FIGURE 3-22
Geometry of a flying spot scanner.

Advantages of digital survey system

- Data can be accessed during or after the flight.
- the entire digital process is conducted without film processing.
- The process is free from chemistry and no darkroom or laboratory is required.
- Expensive and time consuming film scanning is no longer required.
- small and medium format cameras are less expensive than conventional (film-based) mapping cameras
- Images quality and resolution match conventional requirements.
- Digital color infrared (CIR) data can be accessed and processed by the client (no skilled laboratory technician needed)
- Digital image files are more easily stored and accessed (and at less expense) than rolls of 23 cm air film.

Comparison of photographic versus electronic Image Processing

Characteristic	Photographic processing	Electronic Image processing
Data capture	Silver halide film in a camera	photosensitive solid-state devices (CCDs)
Data storage	Photographic film or print	Magnetic, optical, and solid-state media
Data manipulation	Chemical development and optical printing	Digital image processing
data transmission	Mail, delivery service, fax	Telemetry, telephone line, computer networks
soft copy display	Projected slides or movies	computer monitors, television, projection video
hardcopy display	Silver halide prints	Thermal, ink jet, and electrophotographic printers.

DATA STORAGE AND COMPRESSION

- Storage and data compression techniques are vital components of any digital photogrammetric system.
- In fact, without advancements in storage and data compression technologies, there would be no practical use of digital photogrammetry besides academic research.
- Digitizing a photograph with small pixel size would involve a huge storage data.
- The requirements in term of digital image data can be seen on this table

Pixel size (μm)	pixel per inch (dpi)	pixel per line for 23 cm	pixel per image for (23 cm*23 cm)	If image is quantized at 8 bit per pixel (bits)
10	2540	23,000	529,000,000	4,232,000,000
25	1016	9,200	84,640,000	677,120,000
50	508	4,600	21,160,000	169,280,000

Types of data storage

■ Disks

- It is based on magnetic storage.
- Removable magnetic storage disks with capacities from about 40 megabytes to more than 1 gigabytes are commonly available.
- The speed of access of hard disk is fast.
- Floppy disks are not used because of their inability to hold large amount of data.

■ Tapes

- Very slow, because access of any particular location on the tape requires rewinding and searching.
- They devices are usually only useful for backing up a random access hard disk.
- It is less expensive than others are.

■ Cds and DVDs

- It offer the permanent archival storage (so-called write-once read-many or WORM drives)
- It is slower than disks but faster than tapes.
- Since the disks are removable, a single drive can be used to provide essentially unlimited storage.
- One of the limitations is that in most cases, the writing operation must be performed in a single session.

Data Compression

- The heart of any of the image compression techniques centers on two entities:
 1. The development of an image representation that removes a significant amount of the inherent redundancy in the image data.
 2. The achievement of a reconstruction scheme that “undo” the compression or encoding scheme.
- Compression techniques focus on reducing the number of bits required to represent an image by removing or reducing redundancies in images.

Data Compression

- The compression ratio (CR) is defined to be:

$$CR = \frac{\text{Number of bits for original image}}{\text{Number of bits for compressed image}}$$

- Measures of compression algorithm performance are basically composed of three entities:
 1. A quantitative measure of the amount of data reduction in terms of memory bits per image.
 2. A quantitative or qualitative assessment of the degradation (if any) of the image data.
 3. A measure of the algorithm complexity, particularly with respect to compression/expansion processing speed.

Types of compression techniques:

- Lossless compression techniques:
 - The image is encoded to guarantee exact recovery of every source image sample value.
 - For typical images, the values of adjacent pixels are highly correlated; that is, a great deal of information about a pixel value can be obtained by inspecting its neighboring **pixel values**.

- An example:
- A simple approach is to keep just the difference between each pixel and the previous one.
- Since most areas of the image have little change, this reduced the average magnitude of the numbers, so instead of requiring 8 bits per pixel, fewer bits were needed.

8-bit	Min=28	Max=85	43	51	66	75	85	73	64	58	44	38	30	29	28	35	45
5-bit	Min=-15	Max=14		-8	-15	-9	-10	12	9	6	14	6	8	1	1	-7	-10

- Lossy compression techniques
 - The degradations are allowed in the reconstructed image in exchange for a reduced bit rate as compared to lossless techniques.
 - It is particularly important when images are being compressed for “real time” transmission.
 - Much higher compression rate can often be achieved.

- An example:
- The same as the one above except with one restriction; only allow a maximum change of ± 7 gray levels.
- This restriction would reduce the number of bits per pixel from 8 to 4.

8-bit	Min=28	Max=85	43	51	66	75	85	73	64	58	44	38	30	29	28	35	45
5-bit	Min= -15	Max=14		-8	-15	-9	-10	12	9	6	14	6	8	1	1	-7	-10
4-bit	Min= -7	Max=7		-7	-7	-7	-7	7	7	6	7	6	7	1	1	-7	-7
7-bit	Min= 30	Max=73	43	50	57	64	71	64	57	51	44	38	31	30	29	36	43

Data Compression

- Image compression is an integral part of softcopy systems.
- Handling very large digital images is already a daily practice.
- Currently, most of the commercial softcopy systems use the industry standard JPEG still, continuous-tone lossy image compression scheme.
- To achieve high performance, the compression is typically implemented in hardware.

Digital Rectification and Model Formation

- After scanning the images and storing it, we ready now to work with them.
- However, These images have some problems that need to be corrected:
 - **Geometric distortions** which are caused by the imaging and the scanning microdensitometer systems.
 - Typical factors causing the geometric distortions are:
 - lens distortion,
 - film-base instability,
 - non-orthogonality of axes the microdensitometer's and
 - non-linear movement of its flying spot, etc.

Digital Rectification and Model Formation

- **Geometric displacements** which originate from sources such as
 - the deviation of the camera axis from the vertical,
 - terrain relief,
 - earth curvature, etc.
- In normal photogrammetric practice, an image which is corrected for geometric distortions and displacements (excluding relief displacement) is referred to as a **rectified image**.
- If the geometric corrections also include the relief displacement, the final product will be referred to as an **orthophotograph**.

Digital Rectification and Model Formation

- Our concern here is to rectify the images for only the tilt displacements and the geometric distortions and therefore, to retain the relief displacements.
- Relief displacements are used for
 - the reconstruction of a three-dimensional model of the terrain,
 - the stereo-viewing of the left and right digitally rectified images and
 - the subsequent measurement of the model.

■ Digital geometrical rectification

- Digital geometrical rectification usually comprises two stages:

- **Analytical rectification:** which each pixel position in the digital image is corrected for the geometric displacements and distortions
- **The resampling:** assignment of density values to each corrected pixel location based on methods which will be explained later.

Analytical Rectification

- The analytical rectification of digitized aerial photographs is in principle similar to the well known conventional procedures applied in non-digital photogrammetry which are:
 - Interior orientation: establish the position of the projection center
 - Relative and absolute orientation to reconstruct the position of the camera at exposure time.
- To perform these three orientation procedures, fiducial marks, image points and image control points must be measured accurately.

- The manner of carrying out these measurements on digital images is quite different to those used with non-digital images.
- In the conventional case, the human operator performs the measurement task.
- In digital photogrammetric process, there are two possible methods for target measurement:
 - **Manual measurement** of the individual pixels displayed on display device using a cursor
 - Using **mathematical algorithms** which are employed to automatically locate the centers of the required targets. (will be discussed later)

Interior Orientation

- The interior orientation process is a well-known method that relates the geometry of photographs to the original camera that was used to take them.
- After digitizing the photographic images, we have the image matrix, in the coordinate system of the scanner, which will be defined here as the row, col-system.
- However, the photographs have the central projection which is base on the camera xy-coordinate system.
- Therefore, the scanner row, col-system is transformed to the camera xy-coordinates system.

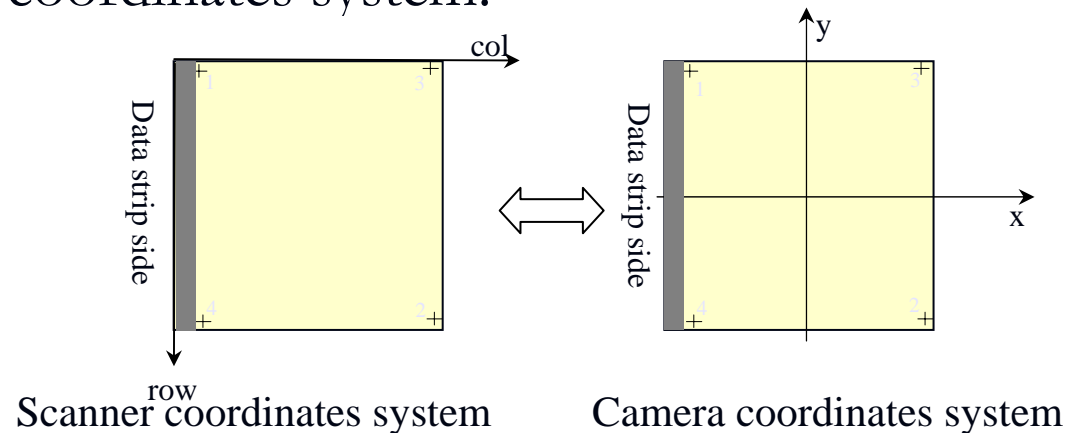

Interior Orientation

- The fiducial marks are used as control to transform the photograph from scanner row, col-coordinates to the camera xy-system.
- As a result, the coordinates of the center of the fiducial marks should be measured.
- The measurement can be performed either manually (by using a mouse and click on each one) or automatically.
- In digital photogrammetry, the manual location is obviously supported by a computer.
- The entire image is displayed on the monitor screen and then a zoom feature –sometimes in several steps- up to the resolution of the original digitization is necessary.

Interior Orientation

- In order to reach the desired sub-pixel accuracy in the fine measurement,
 - the digital image is often “expanded” by assigning each individual pixel of the digitized photograph to several neighboring screen pixels.
 - An interpolation of densities (gray values) may follow this expansion.
- After the coordinates of the center of the fiducial marks have been determined,
 - a two-dimensional transformation is performed to establish the relationship between the measured fiducial marks on the scanner system and the calibrated coordinates of the fiducial marks which are on the camera coordinates system.

- This transformation is performed using a two-dimensional affine transformation given by:

$$x = a1 + a2 \text{ row} + a3 \text{ col}$$

$$y = b1 + b2 \text{ row} + b3 \text{ col}$$

where:

x, y are the coordinates of fiducial marks of the camera coordinates system, col, row are the scanner coordinates of the fiducial marks, and a 's and b 's are the parameters of the affine transformation.

- A pair of equations can be written for each fiducial mark.
- Any three fiducial marks will yield a unique solution for the unknown a and b coefficients.
- If more than three fiducial marks is used, an improved solution may be obtained by solving these equations simultaneously using least squares.

The least squares solution

- Two observation equations are formed for each fiducial mark as follow:

$$x + v_x = a_1 + a_2 \text{ row} + a_3 \text{ col}$$

$$y + v_y = b_1 + b_2 \text{ row} + b_3 \text{ col}$$

- 4 fiducial marks \rightarrow 8 equations.
- There are only 6 unknown parameters.
- A least squares solution is used to obtain the most probable transformation factors.

The least squares solution

- These two equations are formulated for each fiducial point.
- These equations may be represented in matrix form as follow:

$${}_8A_6 \quad {}_6X_1 = {}_8L_1 + {}_8V_1$$

Where

A is the matrix of coefficient of the unknown transformation factors

X is the matrix of unknown transformation factors

L is the matrix of constant terms which is made of control points coordinates

V is the matrix of the residual discrepancies in those coordinates.

The least squares solution

$$A = \begin{bmatrix} 1 & row_1 & col_1 & 0 & 0 & 0 \\ 1 & row_2 & col_2 & 0 & 0 & 0 \\ 1 & row_3 & col_3 & 0 & 0 & 0 \\ 1 & row_4 & col_4 & 0 & 0 & 0 \\ 0 & 0 & 0 & 1 & row_1 & col_1 \\ 0 & 0 & 0 & 1 & row_2 & col_2 \\ 0 & 0 & 0 & 1 & row_3 & col_3 \\ 0 & 0 & 0 & 1 & row_4 & col_4 \end{bmatrix}^6$$

$$X = \begin{bmatrix} a_1 \\ a_2 \\ a_3 \\ b_1 \\ b_2 \\ b_3 \end{bmatrix}^1$$

$$L = \begin{bmatrix} x_1 \\ x_2 \\ x_3 \\ x_4 \\ y_1 \\ y_2 \\ y_3 \\ y_4 \end{bmatrix}^1$$

$$V = \begin{bmatrix} v_{x1} \\ v_{x2} \\ v_{x3} \\ v_{x4} \\ v_{y1} \\ v_{y2} \\ v_{y3} \\ v_{y4} \end{bmatrix}^1$$

- The normal equations are obtained using the following matrix form:

$$A^T A X = A^T L$$

$$(A^T A)^{-1} A^T A X = (A^T A)^{-1} A^T L$$

$$I X = (A^T A)^{-1} A^T L$$

$$X = (A^T A)^{-1} A^T L$$

The least squares solution

- calculating residuals after adjustment is

$$V = A X - L$$

- The standard deviation of unit weight for an adjustment is

$$S_o = \sqrt{\frac{(V^T V)}{r}} \quad r = m - n$$

- Standard deviations of the adjusted quantities are

$$S_{X_i} = S_o \sqrt{(Q_{X_i X_i})}$$

- Where S_{X_i} is the standard deviation of the i th adjusted quantity
- $Q_{X_i X_i}$ is the element in the i th row and the j th column of the matrix $(A^T A)^{-1}$
- The $(A^T A)^{-1}$ matrix is called covariance matrix.
- S_{X_i} tells us that 68 percent probability that the adjusted values of X_i are within $\pm S_{X_i}$ of their true value.

Digital Image Display

- The digital images may need to be displayed to allow:
 - measurement
 - interpretation of information
 - to verify results obtained automatically.
- For simple interpretation and verification, it may suffice to view the digital images monoscopically.
- But when 3-D geometric information is to be checked or measured, a stereoviewing capability is necessary.
- The display of digital images and superimposed vector information requires high resolution monitors (e.g. 1280 x 1024) in 8-bit color or in 24-bit true color with non-destructive overlay.

Digital Image Display

- Display units have basically two items of hardware:
 1. *Display controller* which sits between the computer and the display device
 - It receives information from the computer and converts it into signals acceptable to the display device.
 2. *Display device* which convert the signals received from by display controller into a visible image. A Cathode Ray Tube (CRT) is the device mainly used for this purpose.

- For many photogrammetric operations, like the orientation procedures it is necessary to **roam** through an image or the stereo model in real-time.

- Major principles of roaming:

1. Moving image and a fixed cursor at the center of the viewing area.

- Simulate the familiar situation from the analytical plotter.
- The required real-time roaming puts high demands on the graphics subsystem to receive a continuous, smooth movement, without delays.
- Eyestrain can occur in case of discontinuous displacements.

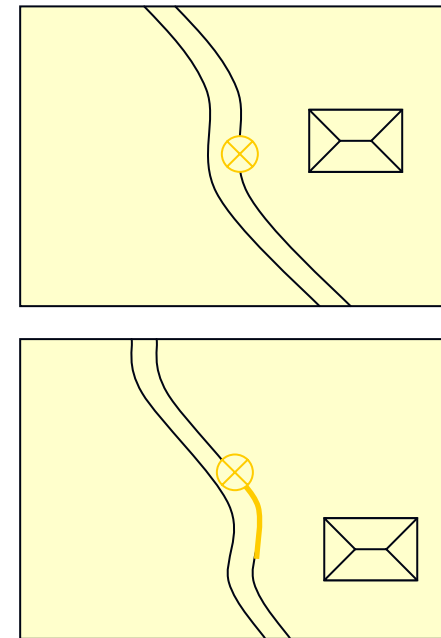

2. Fixed image and moving cursor:
 - The demands on the real time roaming are much reduced.
 - A smooth motion can be achieved, but problems occur while moving close or across the boundary.
3. A combination of the above approaches.
 - For example, x-parallax measurement may be carried out by the cursor and the common movements in the x and y-directions are performed by shifting the image.

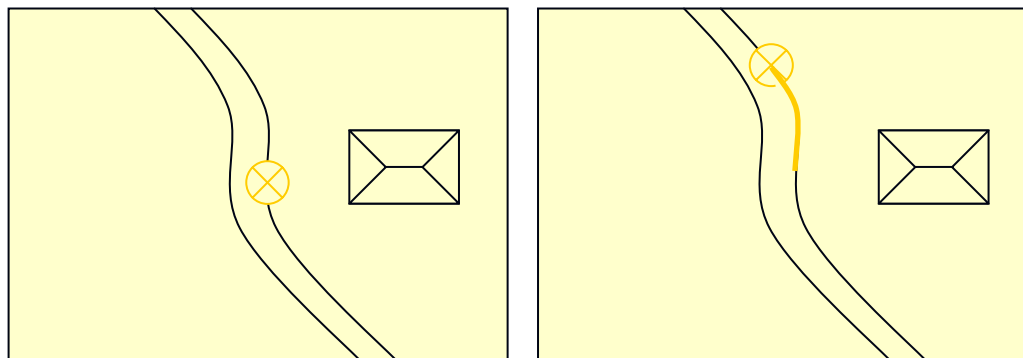

Stereo Viewing

- One of the main requirements for implementing digital photogrammetric system, is to make possible the **three-dimensional viewing** of the digital left and right overlapping images
- Main requirements of implementing stereo viewing and measurements, in addition to a digital computer, are:
 - The data of the two images are displayed in such a way that stereoscopic vision is made possible;
 - For stereo-photogrammetric measurements, a real time three-dimensional control of the measuring marks (cursors) is provided.

Stereo Viewing

- **Stereo viewing in a computer becomes useful because of:**
 - the advanced stereoscopic viewing techniques,
 - computer availability,
 - increased resolution of CRT color monitors,
 - advanced graphic boards, and
 - digital image processing methods.
- **The stereo viewing requires the separation of the two images of a stereo pair.**
- **There are many techniques and variations of performing an alternated stereo viewing on computer**

Stereo Viewing Techniques

The split screen

- The use of a single screen on which allows two images appear side by side.
- The viewer uses an arrangement of prisms, mirrors, or lenses to direct the two images to the corresponding eye.
- Disadvantages
 - It reduces the coverage to only half the size of the display device.
 - only one can look in stereo at a given time.
- It provides a familiar environment to operators used to an Analytical Plotter and allows the use of standard monitors 60 Hz and graphic adapters.



Stereo Viewing Techniques

- **The anaglyphic viewing**
 - An anaglyph is a picture of combining two images of the same object recorded from different points of view, one image in one color being superposed upon the second image in a contrasting color.
 - The red channel contains the right image and the blue channel contains the left image.
 - These two images are overlapped with some parallax on the CRT and viewed through a pair of glasses with red and blue filters.
 - With this technique, no color images or color superimposition can be used for stereo.

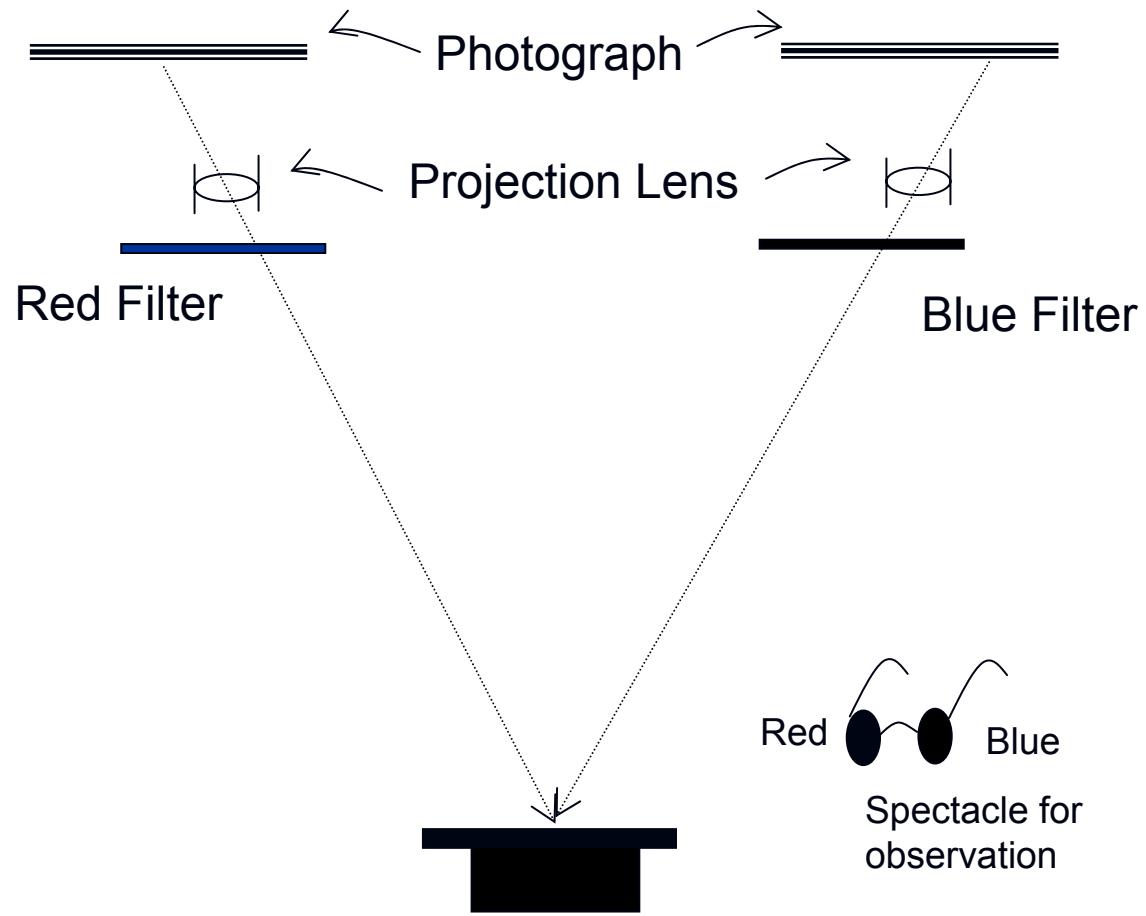

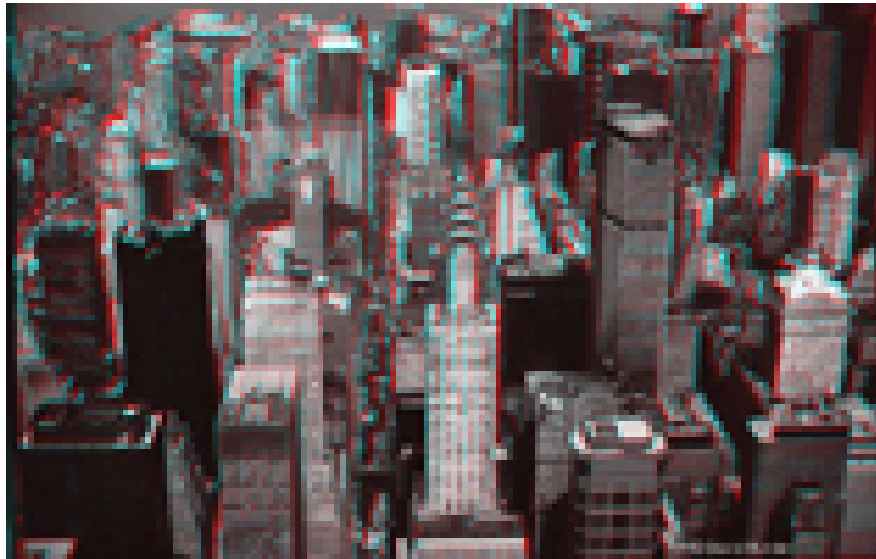
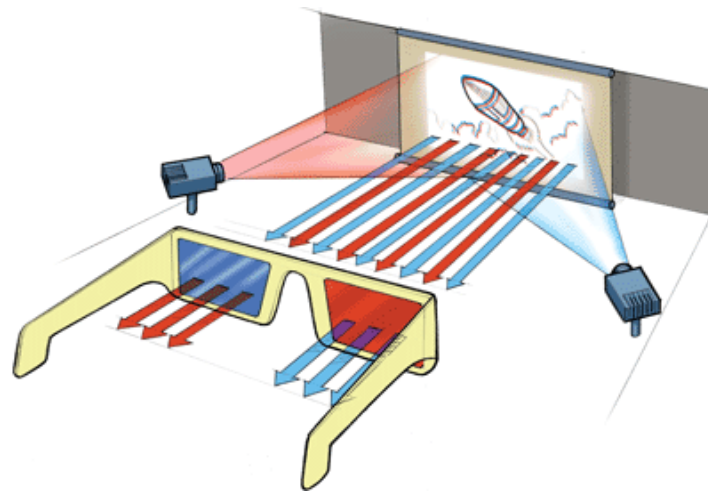

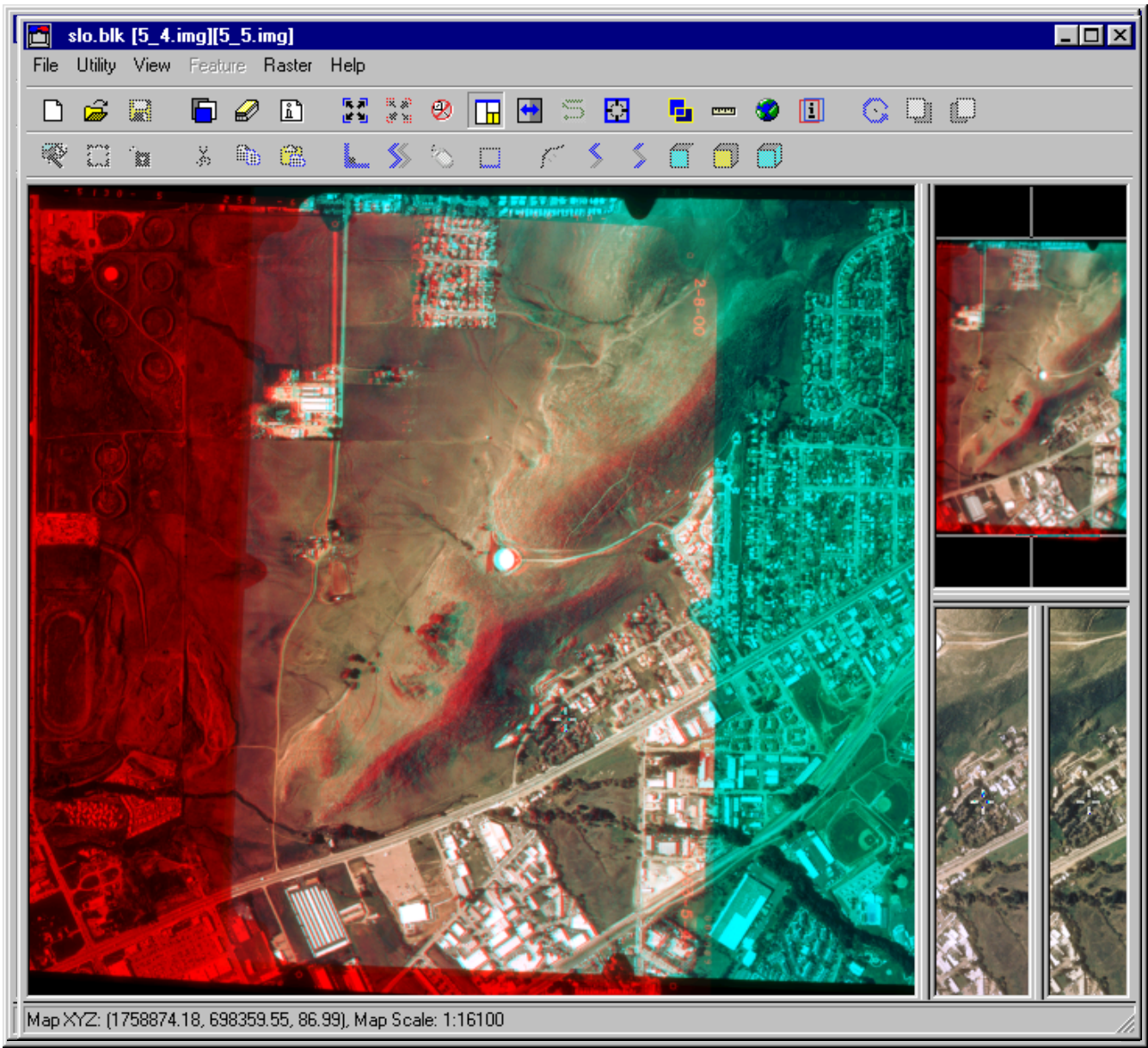

Stereo Viewing Techniques

■ **Passive polarization**

- A polarization screen is mounted in front of the monitor.
- The images are displayed sequentially at a rate of 120 Hz and the polarization screen changes the polarization in synchronization with image display.
- The operator uses passive viewing glasses that are vertically and horizontally polarized.

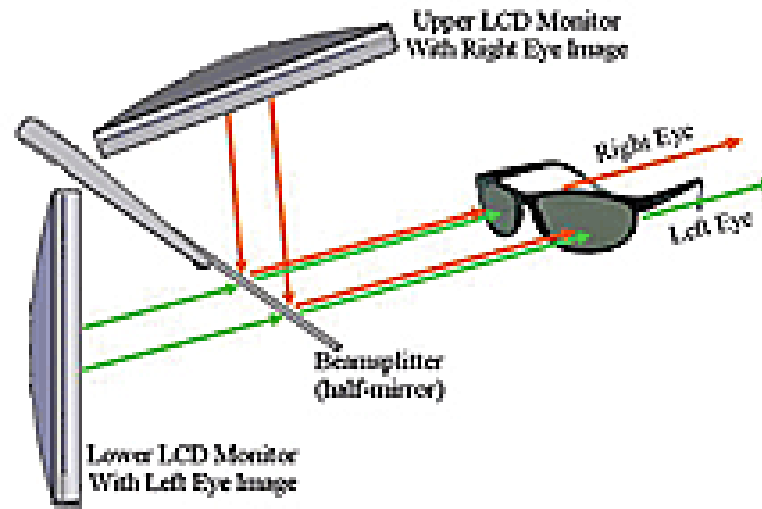

StereoMirror™ Display



Stereo Viewing Techniques

■ Active polarization

- The polarization is integrated into the viewing glasses.
- The images are displayed sequentially with a frequency of 120 Hz.
- The crystal glasses use crystal eyes shutter in LCD (Liquid Crystal Display) technique to polarize the light in synchronization with the image display.
- The synchronization is enables by wireless communication.
- These types of glasses have higher weight due to the LCD shutter and the required battery.
- The advantage of the last two methods:
 - several users can look in stereo at the same time on the same monitor with free head movement.
 - allow the display of color images and color superimposition.
- The major disadvantage is the reduction in brightness compared to a normal monitor due to the doubled frequency and the absorption of light by the polarization screen or the LCD shutter.

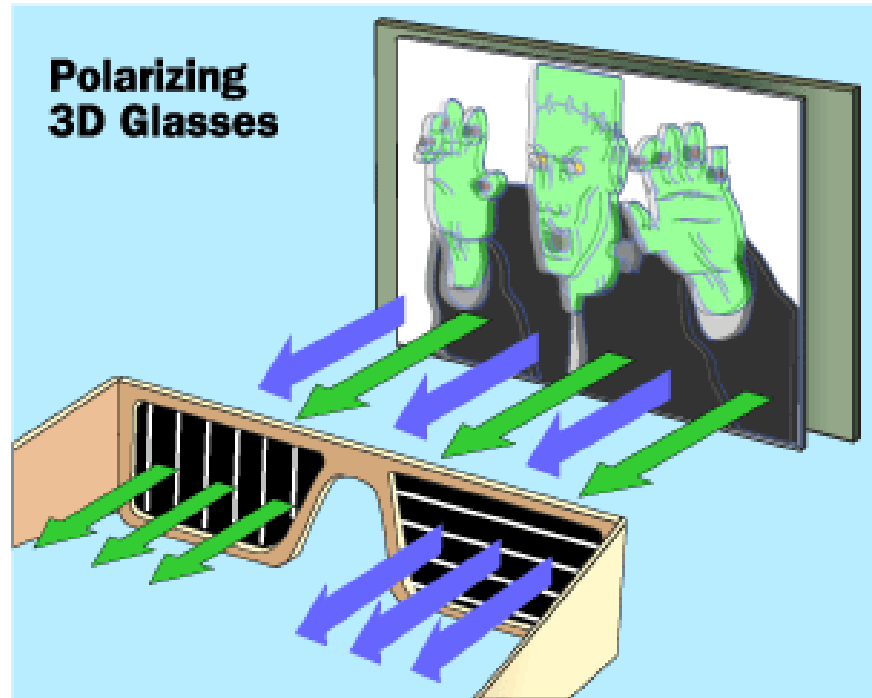

DIGITAL IMAGE MATCHING

- Main task of a stereoplotter operator is stereo-viewing
 - he matches corresponding images in overlapping photographs.
- On the stereoplotter, the operator identifies and measures a feature of the object space in all overlapping photographs.
- In photogrammetry, the process of finding conjugate features in two or more images is commonly referred to as the image matching problem.
- An alternative to this manual operation is automatic image matching (image correlation) or mathematical (computation) approaches.

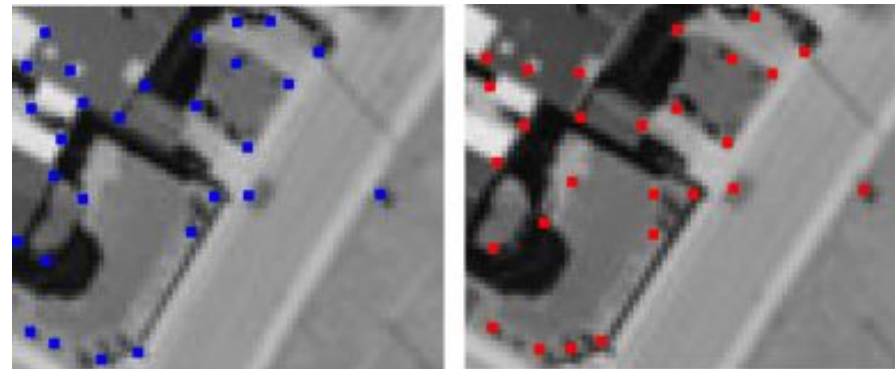

DIGITAL IMAGE MATCHING

- The image matching problem can be described as comparing a specific feature with a set of other features and selecting the **'best'** candidate based on criteria such as shape, intensity value, etc.
- Fusing together two corresponding image patches to a three-dimensional object is something we do without conscious effort.
- Despite impressive computer solutions we are not near the human capabilities of seeing stereoscopically

DIGITAL IMAGE MATCHING

- Automatic image matching > Hobrough (1959)
- Who first automated the orientation movements and height measurements of a Kelsh Plotter by incorporating an analogue image correlator.
- Digital photogrammetry not only attempts to duplicate existing analytical procedures, but also to automate process normally performed by operators.
- In general, three criteria characterize matching techniques:
 - The selection of features to be matched. Features can be in the form of patches extracted from the image, edges, or specific objects.
 - The control strategy that specify how to find a potential match.
 - The criteria for determining (selecting) the best match from several candidates.

Basic Definitions

- **Conjugate entity** is more general term than conjugate point. Conjugate entities are the images of object space features, including points, lines and areas.
- **Matching entity** is the primitive which is compared with primitives in other images to find conjugate entities. Primitives include gray levels, features, and symbolic description.
- **Similarity measure** is a quantitative measure of how well matching entities correspond to each other. The degree of similarity can either be a maximum or minimum criteria.
- **Matching strategy** refers to the concept overall scheme of the solution of the image matching problem. Strategies include: hierarchical approach, and neural network approach.

Matching Method	Similarity entity	Matching entity
Area-based matching	Correlation	Gray levels
	Least-squares matching	
Feature-based matching	Cost function	Edges

- The problem of image matching can be stated as follows:
 1. Select a matching entity (point or feature) in one image.
 2. Find its conjugate (corresponding) entity in the other image using one of the matching methods
 3. Compute the 3-D location of the matched entity in object space.
 4. Assess the quality of the match.
- Obviously, the second step is most difficult to solve.

Matching Methods

- Finding conjugate points is known as image matching, sometimes also called image correlation.
- Two of the best known image matching methods are:
 - Area-based matching
 - Feature-based matching

Area-Based Matching

- The entities in area-based matching are **gray levels**.
- The idea here is to compare the gray level distribution of a small sub-image, called *image patch*, with its counterpart in the other image.
- The *template* is the image patch which usually remains in a fixed position in one of the images.
- The search window refers to the search space within which image patches are compared with the template
- The comparison is performed with different similarity measure criteria.
- The two best known criteria are *cross-correlation* and *least squares matching*.
- The satisfaction of this criterion can be determined by either maximizing the cross-correlation coefficient or minimizing the gray value difference using least squares matching.

The Cross Correlation Method

- The cross correlation is applied as a systematic trial-and-error procedure and its popularity lies in its simplicity and fast processing speed.

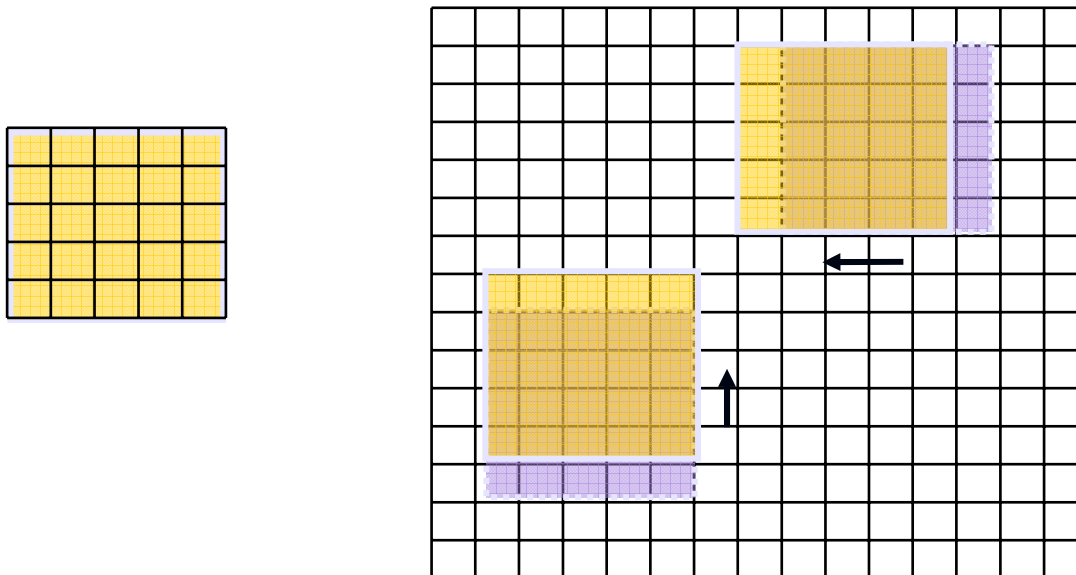

The Cross Correlation Method

- The correlation coefficient is a measure of linear dependency between two gray values
- It is strongly affected by the gray value variation within each window.
- Therefore, homogeneous or repetitive texture, e.g., a sand dune, parking lot, or grass field, will result in high correlation coefficient and yield multiple locations.
- The correlation coefficient R is computed from the standard deviations σ_1 and σ_2 of the gray levels g_1 and g_2 in both area and from the covariance σ_{12} between the gray levels in both areas.

$$R = \frac{\sigma_{12}}{\sqrt{\sigma_1 \cdot \sigma_2}}$$

The Cross Correlation Method

- The normalized cross correlation coefficient between the left reference window $g_1(i,j)$ and the right search window $g_2(i,j)$ is:

$$R = \frac{\sum_{i=1}^M \sum_{j=1}^N (g_1(i,j) - \bar{g}_1)(g_2(i,j) - \bar{g}_2)}{\sqrt{\sum_{i=1}^M \sum_{j=1}^N (g_1(i,j) - \bar{g}_1)^2 \cdot \sum_{i=1}^M \sum_{j=1}^N (g_2(i,j) - \bar{g}_2)^2}}$$

Where

$$\bar{g}_1 = \frac{\sum_{i=1}^M \sum_{j=1}^N g_1(i,j)}{N \cdot M} \quad \text{which is the arithmetic mean of the gray level of the reference window. and}$$

$$\bar{g}_2 = \frac{\sum_{i=1}^M \sum_{j=1}^N g_2(i,j)}{N \cdot M} \quad \text{which is the arithmetic mean of the gray level of the search window.}$$

The Cross Correlation Method

- The method is implemented by comparing a fixed left reference template to all possible templates of size $M \times N$ pixels within a search window in the right image.
- The result of this operation is the set of correlation coefficients for each position in the search window.
- The maximum coefficient indicates a best match.

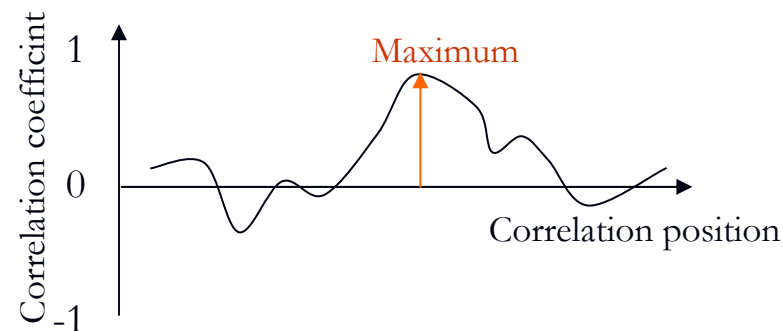

The Cross Correlation Method

■ Procedure

1. Select the center of the template in one image
2. Determine the approximation locations for the conjugate position in the other image
3. For both the template and search window, determine the minimum window size which passes the uniqueness criteria
4. Compute the correlation coefficient $R_{r,c}$ for all positions r,c of the correlation window within the search window.
5. Determine the location of the maximum correlation coefficient (if its $R >$ minimum threshold)

The Cross Correlation Example

■ Example

$$A = \begin{bmatrix} 0 & 0 & 50 & 0 & 0 \\ 0 & 0 & 50 & 0 & 0 \\ 50 & 50 & 50 & 50 & 50 \\ 0 & 0 & 50 & 0 & 0 \\ 0 & 0 & 50 & 0 & 0 \end{bmatrix}$$

1- Extract subarray B from the search array

2- Compute the average for A and B

$$\bar{A} = \frac{0+0+50+\dots+50+0+0}{25} = 18$$

$$\bar{B} = \frac{41+43+43+\dots+62+64+69}{25} = 51.48$$

$$S = \begin{bmatrix} 41 & 43 & 43 & 49 & 60 & 43 & 41 & 40 & 44 \\ 43 & 44 & 45 & 50 & 64 & 45 & 43 & 43 & 45 \\ 42 & 43 & 44 & 48 & 63 & 49 & 45 & 42 & 42 \\ 42 & 45 & 47 & 50 & 65 & 45 & 45 & 41 & 41 \\ 59 & 62 & 62 & 64 & 69 & 64 & 62 & 63 & 60 \\ 50 & 48 & 48 & 51 & 68 & 55 & 50 & 54 & 53 \\ 42 & 41 & 44 & 48 & 63 & 42 & 47 & 47 & 45 \\ 42 & 44 & 42 & 45 & 62 & 44 & 44 & 45 & 43 \\ 42 & 43 & 44 & 48 & 60 & 47 & 44 & 38 & 35 \end{bmatrix}$$

$$B = \begin{bmatrix} 41 & 43 & 43 & 49 & 60 \\ 43 & 44 & 45 & 50 & 64 \\ 42 & 43 & 44 & 48 & 63 \\ 42 & 45 & 47 & 50 & 65 \\ 59 & 62 & 62 & 64 & 69 \end{bmatrix}$$

3- compute the summation terms

$$\sum_{i=1}^m \sum_{j=1}^n [(A_{ij} - \bar{A})(B_{ij} - \bar{B})] = -1316$$

$$\sum_{i=1}^m \sum_{j=1}^n (A_{ij} - \bar{A})^2 = 14400$$

$$\sum_{i=1}^m \sum_{j=1}^n (B_{ij} - \bar{B})^2 = 2102.24$$

4- compute the correlation coefficient

$$c_{11} = \frac{\sum_{i=1}^m \sum_{j=1}^n [(A_{ij} - \bar{A})(B_{ij} - \bar{B})]}{\sqrt{\left[\sum_{i=1}^m \sum_{j=1}^n (A_{ij} - \bar{A})^2 \right] \left[\sum_{i=1}^m \sum_{j=1}^n (B_{ij} - \bar{B})^2 \right]}} = \frac{-1316}{\sqrt{2102.24 \times 14400}} = -0.24$$

5- compute the remaining coefficients

$$C = \begin{bmatrix} -0.24 & -0.09 & 0.35 & -0.19 & -0.19 \\ -0.24 & -0.16 & 0.32 & -0.21 & -0.32 \\ 0.25 & 0.37 & 0.94 & 0.29 & 0.27 \\ -0.08 & -0.02 & 0.50 & -0.06 & 0.03 \\ -0.28 & -0.23 & 0.27 & -0.18 & -0.22 \end{bmatrix}$$

6-Select the maximum correlation coefficient.

0.94 at row 3 , column 3 of the array C
at row 5 and column 5 of the array S

Location of the Template

- The location of the center of the template can only be placed within an area which is half the template size smaller than the image.
- Example: for an overlapping area which covers 2000x1000 pixels and a reference window of 35x35 pixels, the center of the template would be between:

$$\frac{35}{2}, \frac{35}{2} \leq \text{the center of the template} \leq 2000 - \frac{35}{2}, 1000 - \frac{35}{2}$$

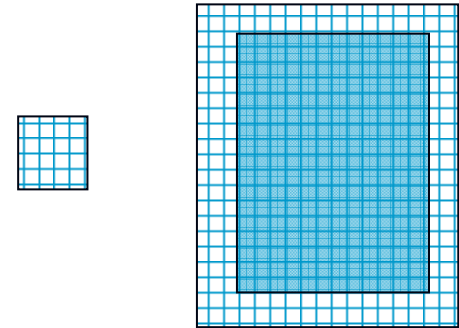

- Actually, certain conditions may cause area based matching to fail, for example,
 - placing the template on areas which are occluded in the other image,
 - selecting an area with low signal to noise ration (SNR) or repetitive pattern
 - selecting an area with breaklines

Approximations, constraints and assumptions

- A problem is said to be well-posed if
 - a solution exists
 - the solution is unique
 - the solution depends continuously on the initial data.
- Image matching is an ill-posed problem because it violates several if not all of the conditions a well-posed problem must meet.
- For example:
 - No solution \succ (occlusion)
 - No unique solution \succ (ambiguity may exist)

Approximations, constraints and assumptions

- To make image matching well-posed, > restrict the space of possible solutions.
- Try to begin the image matching process closer to the true solution.
- Otherwise we may end up with a secondary minimum or require too many iterations to arrive at the global minimum.
- The convergence radius is also called pull-in range.
- The better the approximations the smaller the search space.
- A good step toward making image matching well-posed is to introduce constraints. (epipolar geometry)

Size of the Template

- To avoid mismatches, an appropriate window size should be selected.
- The window size should adapt to the radiometric content of the image as well as the geometry of the terrain.
- If the window is too small and does not cover enough intensity variation, it gives a poor disparity estimate, because the signal to noise ratio is low.
- If on the other hand, the window size is too large and covers a region in which the height of the scene points varies, then the disparity within the window is not constant.
- A compromise must be found, e.g., by computing a uniqueness measure for different template sizes.

Size of the Template

- Methods of uniqueness measure:
 - Variance:
 - A small variance indicates homogenous image
 - Large variance indicates a gray level distribution over a large interval.
 - Autocorrelation:
 - High autocorrelation factor indicates repetitive patterns (no uniqueness)
 - Random image are not correlated (unique)
 - Entropy: (measure of the randomness of the image function)
 - High entropy indicate more more randomness than low numbers

Location and Size of the Search Window

- Since area-based matching depends on very close approximation, the location of the search window is crucial.
- The size of the search window does not play a significant role because shifts of more than a few pixels are suspicious anyway.
- A hierarchical strategy is usually employed to ensure good approximations and reduce time needed.

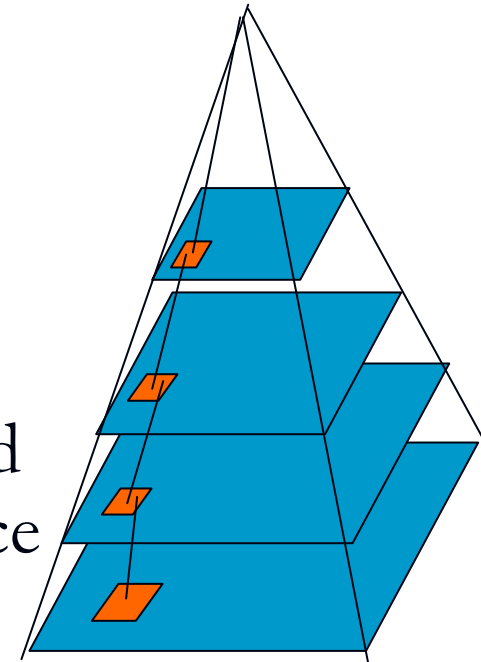

Geometric Distortions of Matching Entities

- The similarity measure yields a maximum if the gray levels of every pixel compared are identical.
- That is when the two images are true vertical and the terrain is flat.

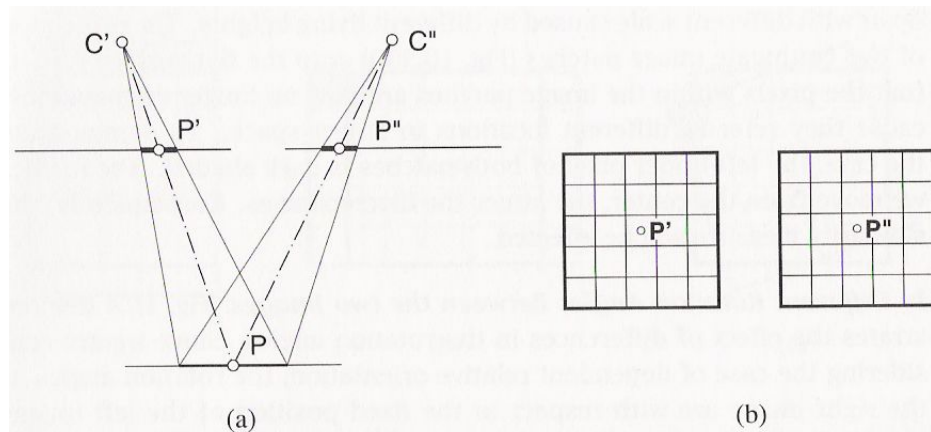

Figure 10.2: A flat surface patch with point P in its center is imaged in two image patches, whose centers are in P' and P'' (a). As indicated in (b), the two image patches are identical in this ideal case.

Geometric Distortions of Matching Entities

- This is an ideal situation which will never occur in reality because:
 - Changing illumination and reflection between two images
 - Change in time of capture
 - Geometric distortion due to central projection and relief.
 - Noise

Geometric Distortions of Matching Entities

- Geometric distortion due to orientation parameters:
 - If image is not oriented, it is important to be aware of the following geometric distortions:
 - Scale difference between the two images > two conjugate image patches are with different sizes
 - Different rotation angles between two images > different sizes and rotations

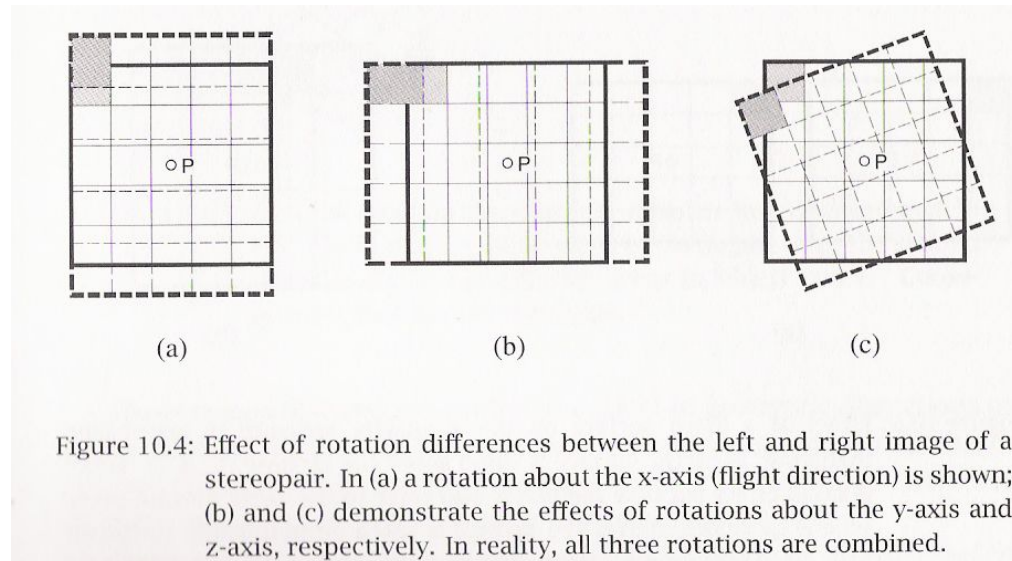
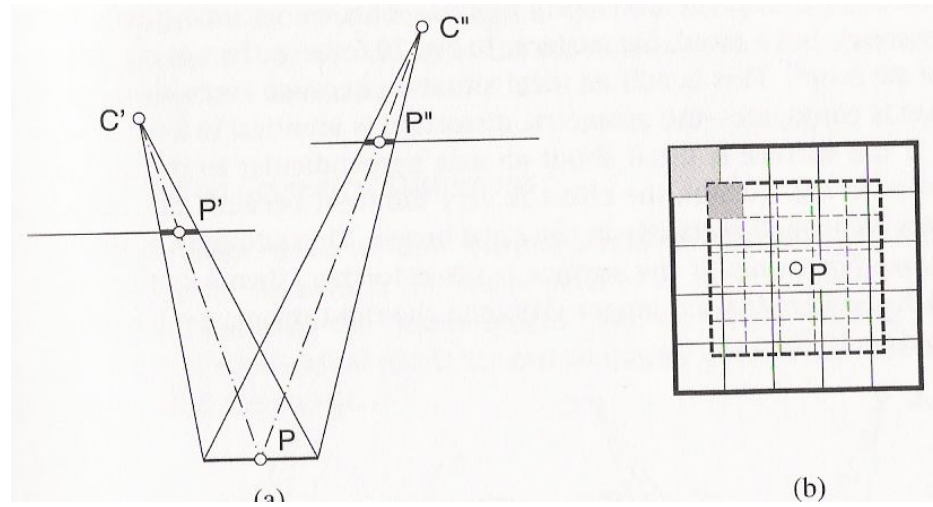
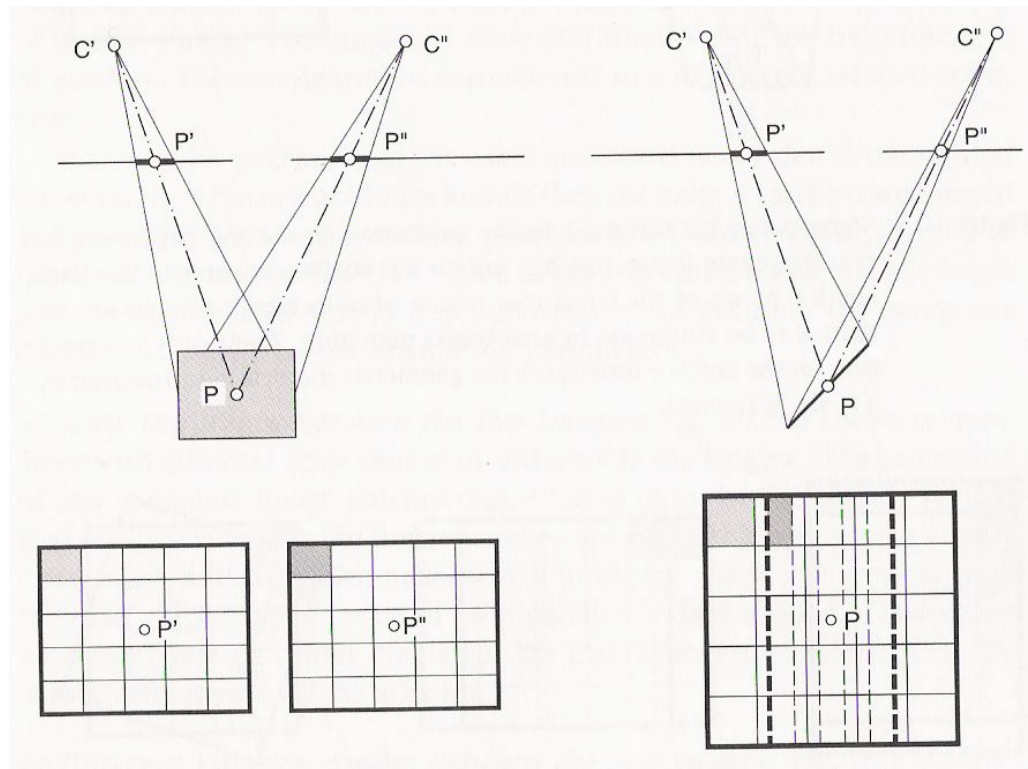

Figure 10.4: Effect of rotation differences between the left and right image of a stereopair. In (a) a rotation about the x-axis (flight direction) is shown; (b) and (c) demonstrate the effects of rotations about the y-axis and z-axis, respectively. In reality, all three rotations are combined.

Geometric Distortions of Matching Entities

- Effect of Tilted surface on geometric distortions
 - We assume that the surface is flat to get perfect square in both images.
 - If the surface is rotated about the air base:
 - No effect (geometric distortion is identical in both images)
 - If the surface is tilted about an axis perpendicular to the air base:
 - the square patch in the left image will correspond to a small rectangular in the right image.



Acceptance Criteria

- The factors obtained for measuring the similarity of the template and matching window must be analyzed.
- Acceptance/rejection criteria often change even within the same image. Threshold values or other criteria should be locally determined on the fly.

Quality control

- The quality control includes an assessment of the accuracy and reliability of the conjugate locations.
- The consistency of the matched points must be analyzed, including the compatibility with expectations or knowledge about the object space.

Least squares Image Matching Method

- The idea is to minimize the gray value differences between the template and the matching window
 - the position and the shape of the matching window are parameters to be determined in the adjustment process.
- The gray values of the image windows are assumed related to one another by a mathematical function (usually, an affine transformation)
- This function compensate for:
 - scale change,
 - perspective distortion as a function of orientation of the camera stations
 - Terrain

Least squares Image Matching Method

- One image window serves as a reference window defined by the image function $f(x,y)$ and the other image window serves as the search window defined by the image function $g(x,y)$.

- The basic assumption is:

$$f(x,y) = g(x_s,y_s)$$

Where x,y = coordinates in the reference window

x_s,y_s = coordinates in the search window.

- However, the image has noise and assuming the noise of one image is independent of the other image,

$$f(x,y) + n(x_s,y_s) = g(x_s,y_s)$$

$n(x_s,y_s)$ = true noise (error) vector.

Least squares Image Matching Method

- The error can be reduced by modeling the differences between the image windows.
- The scale and orientation parameters can be compensated from well known camera models.
- The equation is non-linear and when linearizing the function, it is usually assumed that each window is a separate plane and their relation is defined by an affine (6 parameters) transformation.
- For small patches, an affine transformation is sufficiently describing the relationship between the two patches.

Least squares Image Matching Method

- This caused the search window to be shaped to the reference window as:

$$x = a + b x_s + c y_s$$

$$y = d + e x_s + f y_s$$

a-f = affine model coefficients.

- The linearized observation equation is:

$$f(x,y) + n(x_s,y_s) = g_o(x_s,y_s) + \left(\frac{\partial g_x(x_s,y_s)}{\partial dx_s} \right) dx_s + \left(\frac{\partial g_y(x_s,y_s)}{\partial dy_s} \right) dy_s$$

g_o = initial density location estimation.

- The shaping function is added to more accurately estimate the conjugate point in the search window as”

Least squares Image Matching Method

$$f(x,y) + n(x_s,y_s) = g_o(x_s,y_s) + g_x da + g_x x_s db + g_x y_s dc + g_y dd \\ + g_y x_s de + g_y y_s df$$

where

$$g_x = \partial g_o(x_s,y_s) / \partial x_s$$
$$g_y = \partial g_o(x_s,y_s) / \partial y_s$$

- Implementing these equations into vector notation the resulting observation equation is:

$$N(x_s,y_s) = A X - D$$

$$A = \text{coefficient vector} = \{g_x, g_x x_s, g_x y_s, g_y, g_y x_s, g_y y_s\}$$

$$D = f(x,y) - g_o(x_s,y_s)$$

$$X = \text{vector of transformation parameters } (da, db, dc, dd, de, df)$$

Least squares Image Matching Method

- For a given initial estimate of the location of $g(x_s, y_s)$ corresponding to the reference function $f(x,y)$ the transformation parameters can be determined.
- By updating the coefficients, resampling gray values from updated coordinates, and iterating, a minimum variance solution can be obtained for the transformation parameters.
- Then a conjugate point can be determined.
- In addition to the basic geometric model, a linear radiometric model is added.
- The radiometric transformation simply eliminates differences in the gray level and contrast scale of the two images.

$$f(x,y) = r_0 + r_1 \cdot g(x_s, y_s)$$

Least squares matching procedure

1. Select the center of the template in one image (R_T, C_T)
2. Determine approximate locations for the matching window (R_M, C_M)
3. Determine the minimum size of template and matching window which passes the uniqueness criteria
4. Start first iteration with matching window at location R_M, C_M
5. Transform matching window and determine the gray values for the tessellation (resampling)
6. Repeat adjustment and resampling sequence until termination criteria is reached.
7. Assess quality of conjugate point
8. Repeat steps 1-7 for a new position of template.

Comparison of Cross Correlation and LSM

Property	Cross correlation	LSM
Pull in range	Large	Small
Scale/rotation sensitivity	High	Medium
Occlusion sensitivity	High	High
Accuracy	Medium	High
Multi-image matching	Not available	yes

Advantages of Area-Based Matching

- Flexible mathematical model:
 - LSM is the method of choice in photogrammetry because it provides a general approach to area correlation by offering a mathematical tractable method.
 - It is easy to use multiple images whereby all image patches are matched simultaneously.
 - It enables photogrammetrists to apply familiar mathematical and statistical principles.
- Simple matching algorithm:
 - Both cross-correlation and LSM are considered simple algorithms with well-known procedures for fast implementation.
- Small storage resources:
 - Only the template and the search windows need to be kept in the memory resulting in very little memory requirements.

Disadvantages

■ Breaklines:

- It is assumed that the template and the search window cover a smooth surface area. If this assumption does not hold, then the matching results may be wrong.
- Breaklines possess information about the surface. Unfortunately, ABM performs poorly on these interesting areas.

■ Need a good approximation:

- Very good approximation for the estimated match position must be known, otherwise, the result may be unreliable.

■ Photometric differences:

- ABM methods have difficulties with images of different radiometric properties.
- The radiometric differences between images may result from using
 - Different cameras.
 - Images from different times.
 - Images from different reflections of bright objects such as water bodies, etc.
 - Lab processing noise.

Disadvantages

■ Geometric differences:

- One of the basic assumption of image matching techniques is that the two windows cover the same area in the object space.
- This is only the case if the surface is parallel to the camera base.
- In real situations the two windows cover different areas, hence different gray levels, which affects the matching results.
 - Perspective projection → Height displacements and occluded areas
 - Scale variation → Chang in flying height.
 - B/H problem → The smaller the Base/Height ratio the more similarity in appearance, but worse for depth measurement and vice versa.

■ Problematic texture:

- There is a problem to determine the position of the best match in these areas:
 - Featureless area, such as water bodies, sand, or grass
 - Repetitive texture, such as parking lot, roofs.

Feature-Based Matching

- In feature-based matching (FBM) the conjugate entities are derived properties (features) of the original gray level image.
- The features so determined may include points, corners, edges, and region.
- Edges are by far the most widely used features, although in photogrammetry, feature points, called interest points, are more popular.
- FBM gained popularity in computer vision in the late 1970s when it was realized that the remarkable stereovision ability of humans is based on finding conjugate edges rather than finding similar gray level distribution in a stereopair.

Feature-Based Matching

- Generally, feature-based matching proceeds in two steps:
 1. Detection of specific features using specially designed operators
 - The result will be a list of features elements for each image along with certain attributes, such as position, orientation, shape, gradient, etc.
 2. Matching of detected features
 - After the location of features is determined a relationship between conjugate features is established (matching).
 - This process is usually performed on the basis of similarity of the feature attributes, for example, orientation, shape, gradient, etc.

Feature-Based Matching

- There are two primary types of feature-based operators:
 - **Interest operators** detect point features by evaluating and describing the statistical nature of a point from its neighboring gray values
 - Extracting points in an image with high variance.
 - Points with distinct features are called interest points.

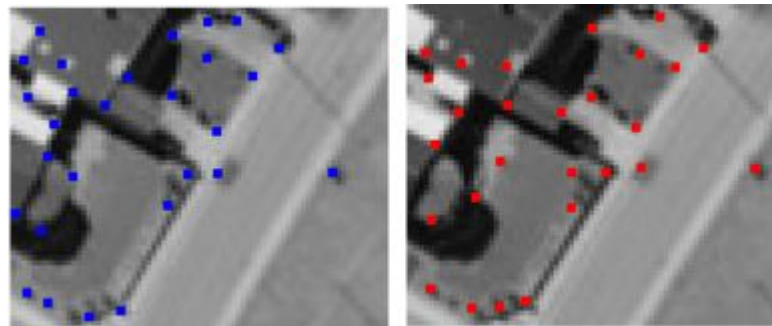

Feature-Based Matching

- **Edge operators** detect local changes in the gray value gradients.
 - Edges correspond to brightness differences in the images
 - Such differences may be abrupt (sharp edge)
 - Or may occur over an extended area (smooth edge)
 - Edges occur at all orientations → use directional independent operator
- The attributes are computed and usually compared to a threshold to decide whether a feature is good or bad.

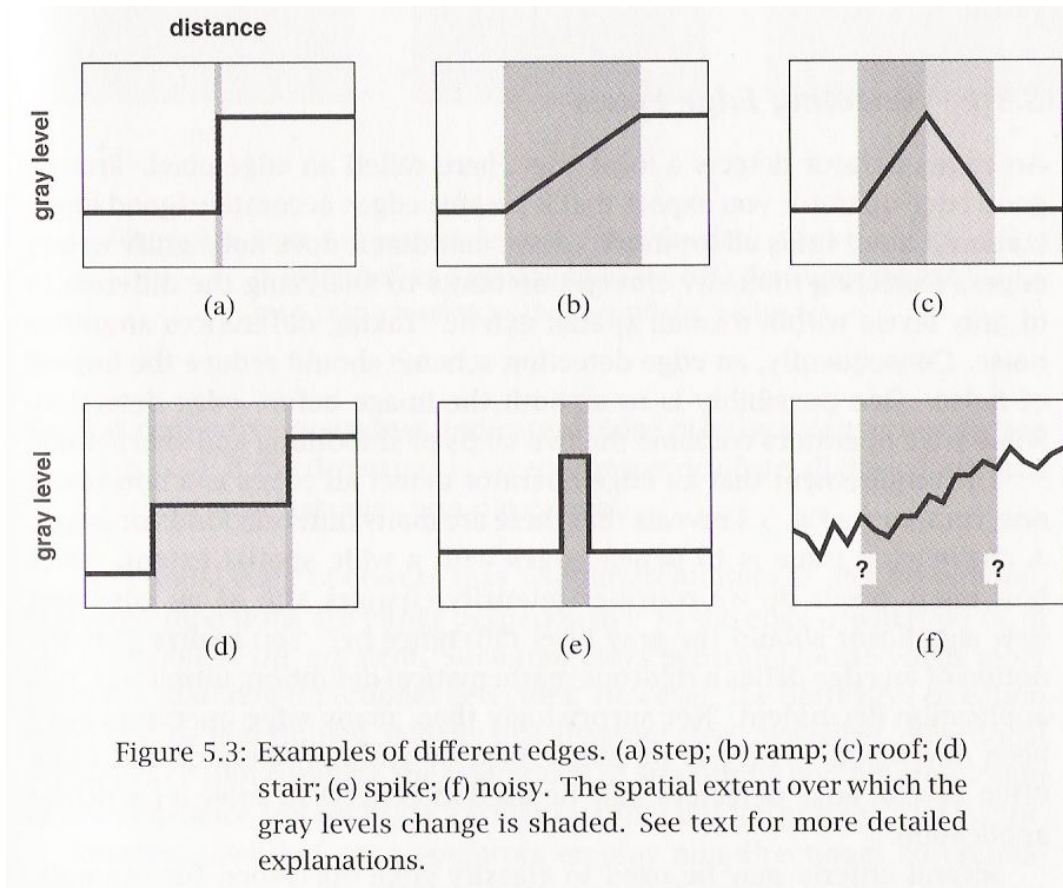

Figure 5.3: Examples of different edges. (a) step; (b) ramp; (c) roof; (d) stair; (e) spike; (f) noisy. The spatial extent over which the gray levels change is shaded. See text for more detailed explanations.

Feature-Based Matching

- The features selected for matching must have the following attributes:
 - *Uniqueness*: the features must be unique in the whole image or in their neighborhood.
 - *Precision in location*: they must be precisely located.
 - *Stability-Invariance*: They must be stable and they should be insensitive to noise.

Feature-Based Matching

- When matching entire edges, the following factors must be considered:
- Conjugate edges occur in similar regions.
 - Given a normal aerial stereopair, it is impossible that an edge in the left upper corner is a conjugate to an edge in the right lower corner.
 - In the example below: edge 1 does not match edge 3 because they are in different regions, but it matches edge 2

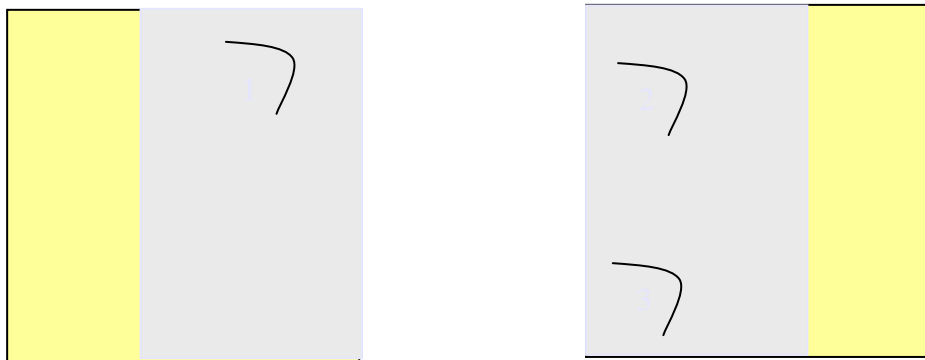

Feature-Based Matching

- Conjugate edges have similar shape and orientation
 - A horizontal edge is not conjugate to a vertical edge, and an S-shape edge is very unlikely to correspond to a question-mark shape.
 - In the example below, edge 4 does not match edge 6 because their orientations are not similar and it does not match edge 3 because they have different shape. However, it matches edge 5 because they have similar shape and orientation.

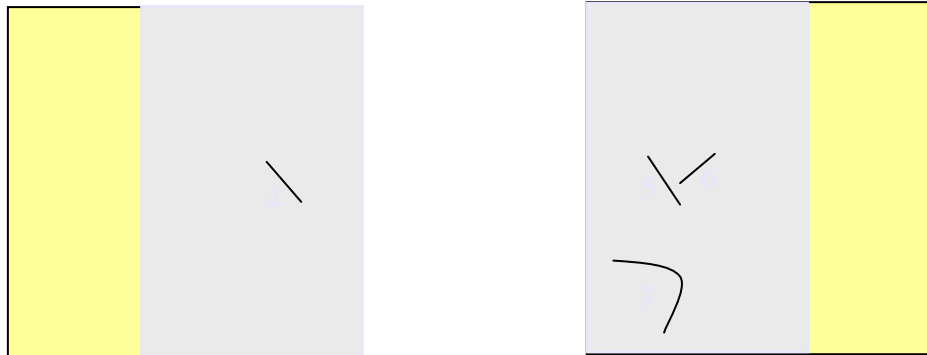

Feature-Based Matching

- Spatial relationships of edges do not change drastically for their conjugate partners.
 - For example, topological properties, e.g. one edge is to the left of another edge, are preserved.
 - In the example below, if edge 1 matches edge 2, then edge 7 cannot be the correct match for edge 4 because of topological reasons.

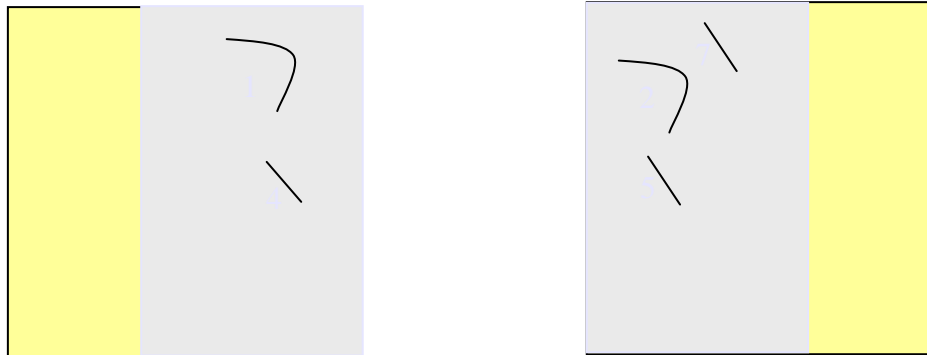

Advantages of Feature-Based Matching

- High reliability:
 - Generally, FBM produces more reliable results than ABM because of the distinctive properties of features.
 - Also features are derived over a large spatial extent and thus add to the robustness.
- Capture important information:
 - Features possess more explicit information about the object space than the raw gray levels.
- Less sensitive to radiometric and geometric distortions;
 - Because of the use of relative values of gray levels, radiometric distortion is less.
 - Images do not change features drastically

Disadvantages of Feature-Based Matching

■ Complex algorithm

- Dealing with features requires more complex data structures and algorithms.
- Matching by searching trees or graphs is less straightforward than cross-correlation.

■ Goodness of match

- Unlike LSM no well-known statistical methods exist to analyze the matching results

■ Sensitivity to texture content.

- Difficult to find a good discrete distinguishable points in featureless areas such as water bodies, sand, and grass.
- May find many good matches in repetitive texture, but wrong matches.

EPIPOLAR GEOMETRY

- Matching in 2D takes longer time and susceptible to errors.
- A commonly used constrained matching algorithm is based on matching along epipolar geometry.
- The main objective of the epipolar geometry is to remove y-parallax between the two images.
- The stereo matching is thus reduced to a 1D case by limiting the correlation of points to corresponding epipolar lines.
- This is advantageous because it speeds up the matching process and decrease the possibility of mismatches.

Geometric Transformation

- Epipolar geometry is a basic and familiar concept in photogrammetry.
- This figure depicts the condition of coplanarity and shows the line of intersection of the epipolar plane with left and right image planes.
- The epipolar plane is defined by the two projection centers C' and C'' and the object point P .
- The epipolar lines are the lines of intersection of the epipolar plane with the left and right images.

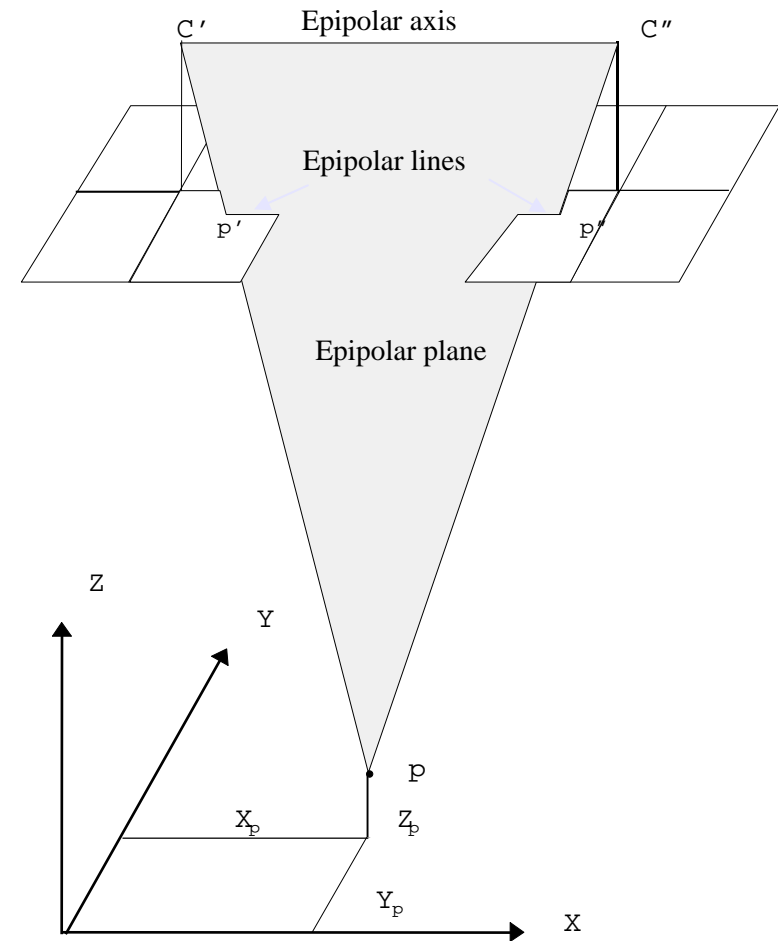

Geometric Transformation

- In a tilted photograph, the corresponding epipolar lines will not be parallel to each other.
- If the corresponding epipolar lines are made parallel to the image scan lines, i.e. the output images are resampled along the epipolar lines, then there will be no y-parallax for the corresponding image points

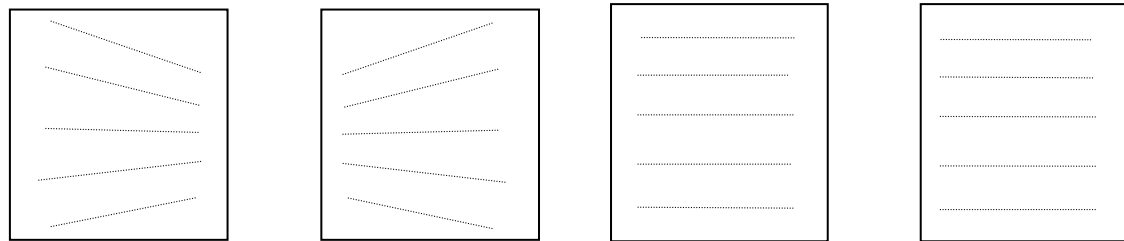

(a)

(b)

(a) Original images and (b) resampled images into epipolar lines.

Geometric Transformation

- There are three causes for the existence of y-parallax:
 - Improper orientation of the photos.
 - Variation of flying height.
 - Tilt of the photos.
- To eliminate these three causes, we first start with the tilt of the photos.
- Tilt exists if omega (ω) and/or phi (ϕ) of an image is not equal to zero.
- To transform both images to true vertical positions, an inverse rotation M^T is applied, where M is an orthogonal rotation matrix to transform from the object space to image space.
- The parameters of M can be obtained from the exterior orientation.

Geometric Transformation

- After eliminating the tilt, both photographs are parallel to the object coordinate system.
- However, there still exists y -parallax because of the other two causes.
- As in figure, the variation in flying heights can be compensated by rotating both images with ϕ (ϕ) with

Geometric Transformation

$$\phi = -\tan^{-1} \frac{BZ}{(BX^2 + BY^2)^{1/2}}$$

where $BX = X_R - X_L$

$BY = Y_R - Y_L$

$BZ = Z_R - Z_L$

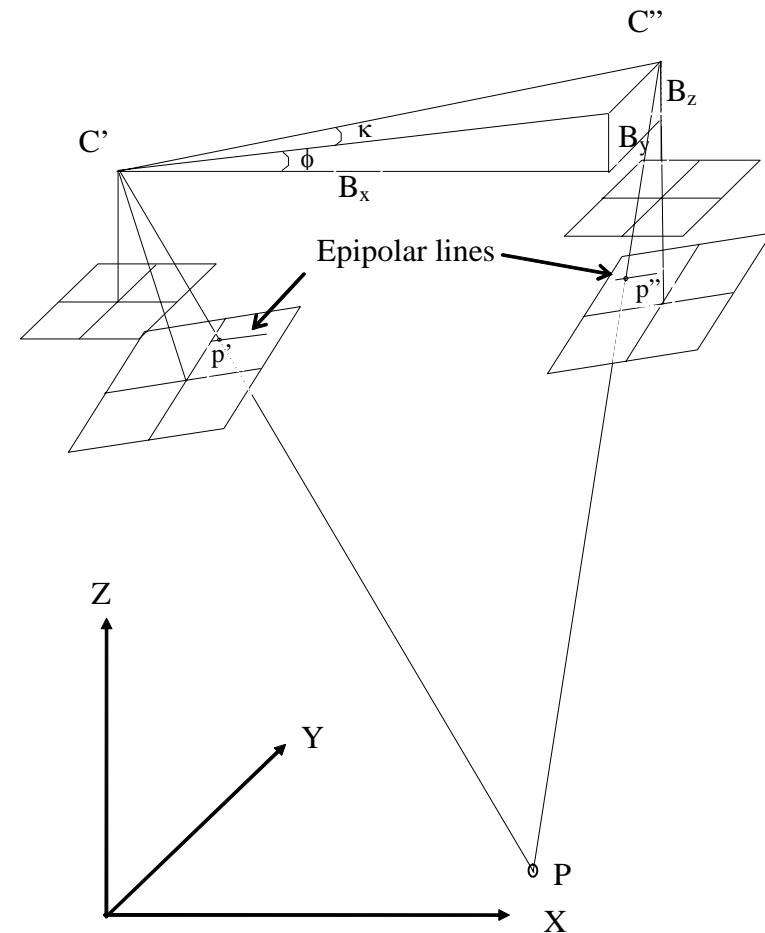

Geometric Transformation

- Improper orientation of the photos is caused by the difference in the Y coordinates.
- Both images should be rotated around Z with kappa to have them aligned.
- The rotation of kappa (κ) is defined as

$$\kappa = \tan^{-1} \frac{BY}{BX}$$

- and omega (ω) can be kept zero.

Geometric Transformation

- These rotations will force the two images to be in one plane and the “flight line” will be parallel to the x-axis of both images.
- The sequence of these two rotations is essential since the values of the rotation angles are calculated according to this sequence.
- The base rotation matrix RB will be as follows:

$$M_B = M_\phi M_k$$
$$M_k = \begin{bmatrix} \cos k & \sin k & 0 \\ -\sin k & \cos k & 0 \\ 0 & 0 & 1 \end{bmatrix}$$

$$M_\phi = \begin{bmatrix} \cos \phi & 0 & -\sin \phi \\ 0 & 1 & 0 \\ \sin \phi & 0 & \cos \phi \end{bmatrix}$$

Geometric Transformation

- The two rotation matrices are combined to form one matrix which transforms the original photos to epipolar geometry photos.

$$M_E = M_B M^T$$

- Matrix M_E establishes the transformation between the original image and the vertical image, where both of them are in the photo coordinate system.
- In digital photogrammetry, the computer deals only with images that are in a pixel coordinate system.

Relationship between original and normalized stereopair

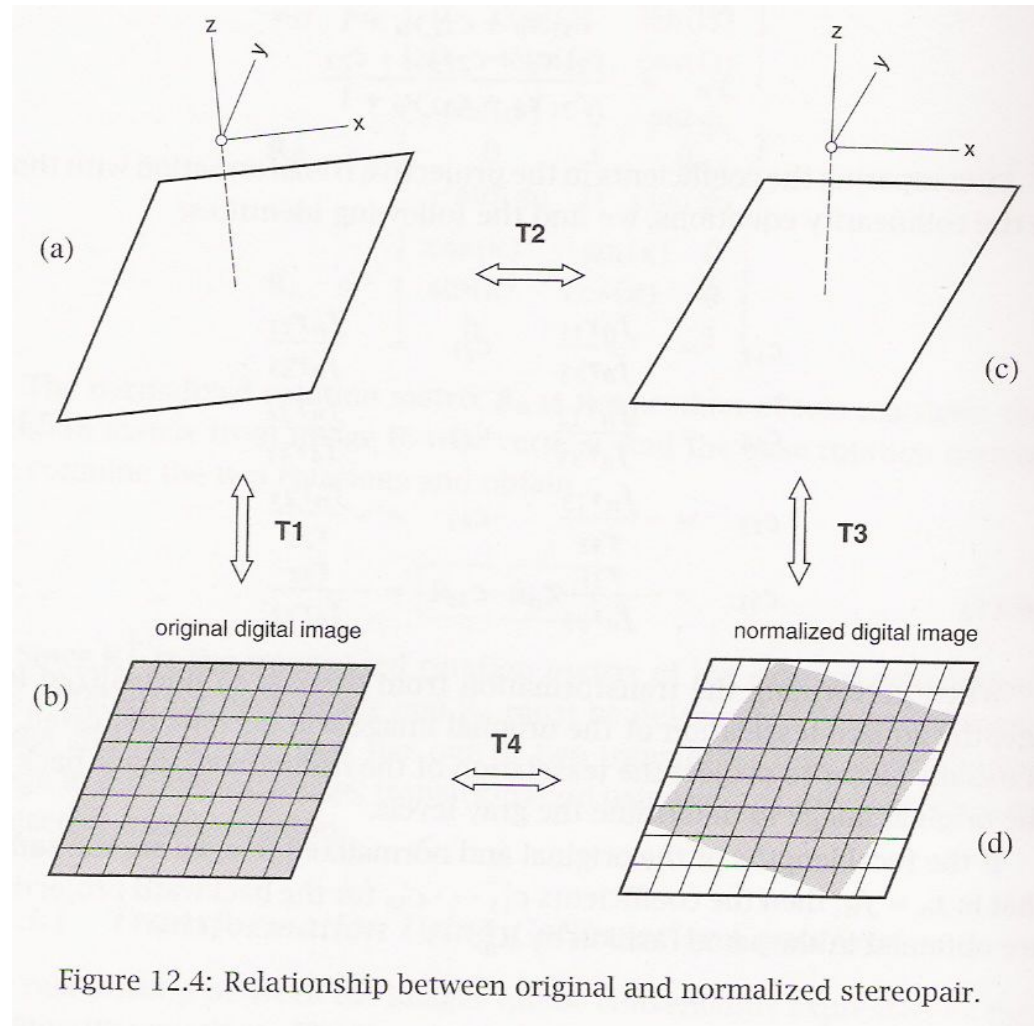

Figure 12.4: Relationship between original and normalized stereopair.

Relationship between original and normalized stereopair

- T_1 Transformation between original photograph and digital image
 - The transformation parameters are determined during the process of interior orientation.

$$x = a1 + a2 \text{ row} + a3 \text{ col}$$

$$y = b1 + b2 \text{ row} + b3 \text{ col}$$

- T_2 is the projective transformation between photographs in original and normalized position.
- We may use two transformations from original image to normalized image:
 1. Using collinearity equations

$$x_n = -f \left[\frac{m_{11}x_o + m_{12}y_o - m_{13}f_o}{m_{31}x_o + m_{32}y_o - m_{33}f_o} \right]$$

$$y_n = -f \left[\frac{m_{21}x_o + m_{22}y_o - m_{23}f_o}{m_{31}x_o + m_{32}y_o - m_{33}f_o} \right]$$

x_o, y_o are photo coordinates of the original images

x_n, y_n are photo coordinates of the normalized images

$m_{11} \dots m_{33}$ are the elements of M_E

2. Projective transformation

- It can be applied since both original image and normalized image are planar

$$x_n = \left[\frac{c_{11}x_o + c_{12}y_o + c_{13}}{c_{31}x_o + c_{32}y_o + 1} \right]$$
$$y_n = \left[\frac{c_{21}x_o + c_{22}y_o + c_{23}}{c_{31}x_o + c_{32}y_o + 1} \right]$$

$$c_{11} = \frac{f_n m_{11}}{f_o m_{33}}$$

$$c_{12} = \frac{f_n m_{12}}{f_o m_{33}}$$

$$c_{13} = -\frac{f_n m_{13}}{r_{33}}$$

$$c_{31} = -\frac{m_{31}}{f_o m_{33}}$$

$$c_{21} = \frac{f_n m_{21}}{f_o m_{33}}$$

$$c_{22} = \frac{f_n m_{22}}{f_o m_{33}}$$

$$c_{23} = -\frac{f_n m_{23}}{r_{33}}$$

$$c_{32} = -\frac{m_{32}}{f_o m_{33}}$$

$$f_o = f_n$$

- T_3 transformation between normalized photo and normalized digital image.
 - establish the origin and size of the normalized digital image.
 - The 2-D conformal transformation is used, where the corners of the image are used to relate the two systems.
 - First, the maximum and minimum x and y photo coordinates are determined as in the figure.
 - The following transformation relates the photo coordinate image to the pixel coordinate image:

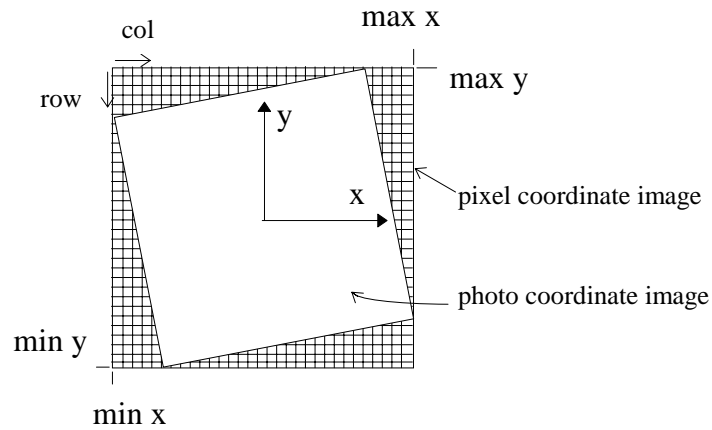

$$x = Tx + col * scale$$

$$y = Ty - row * scale$$

Where x, y are the photo coordinates

col, row are the pixel coordinates

$$T_x = \min(x)$$

$$T_y = \max(y), \text{ and}$$

$$scale = \frac{\max(y) - \min(y)}{nrows}$$

where $nrows$ = no of rows in the original image

- T_4 transformation between original and normalized digital image
 - It corresponds to T_2 but in digital images
 - This relationship is necessary for performing the resampling of the normalized digital image from the original one.

Radiometric Transformation

- This geometric transformation is now used to establish the new position of each pixel of the original image.
- A density value is assigned to each geometrically corrected pixel because the output pixel transformed into the plane of the input image does not necessarily coincide with the center of a pixel in the input image.
- The geometric transformation required for correcting the positions of pixels may be carried out using either of the following two methods:

Radiometric Transformation

- ***The direct method:***
 - In this approach, the positions of the pixels on the original image are corrected by applying the geometrical transformation, with each pixel retaining its gray level.
 - Then the output image will be irregularly distributed.
 - To obtain a regularly distributed output image, a regular grid must be constructed for which the gray levels must be interpolated.

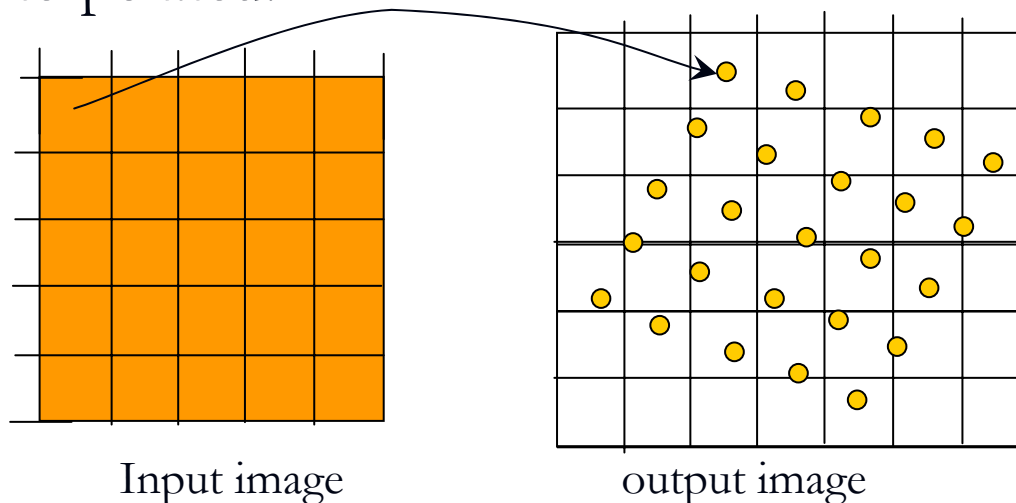

Radiometric Transformation

■ *The indirect method:*

- The output image may be considered to have a regular pixel pattern.
- The gray value for each output pixel can be computed by geometrically transforming the output pixel into the plane of the input pixel image and assigning the gray value of the corresponding pixel on the input plane to the output pixel.
- However, the location of the output pixel after transformation to the input plane will not necessarily coincide with the pixels on the input image.

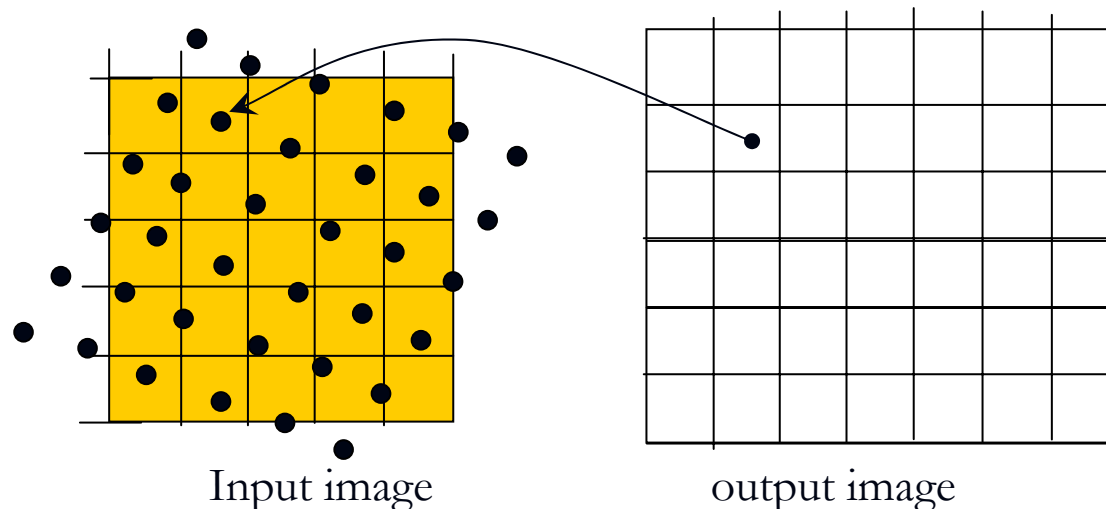

Resampling Methods

- To assign an intensity value to each output pixel, various interpolation schemes can be implemented:
 - **Nearest neighbor**
 - **Bilinear interpolation**
 - **Bicubic interpolation**

Nearest neighbor

- It is the simplest interpolation method because it is a zero-order interpolation.
- This method takes the value of the nearest pixel to the transformed output pixel and assigns it to the output pixel.
- This means that the resulting gray intensity levels correspond to true input pixel values, but the geometric location of a pixel may be inaccurate by as much as ± 0.5 pixel spacing.
- This is a computationally efficient procedure.
- The equation for this process is:

$$g^T(r, s) = g(i, j) \quad r, s: \text{real}; \quad i, j: \text{integer}$$

where

$$i = \text{int}(r+0.5), \quad j = \text{int}(s+0.5)$$

Bilinear interpolation

- This is a first order interpolation.
- The gray values of the four surrounding pixels contribute to the gray value of the transformed output pixel.
- This is done by fitting a plane to the four pixels values and then computing a new gray level based on the weighted distances of these points as seen in the figure.
- The bilinear interpolation is computed according to this equation:

$$g^T(r, s) = (1 - m)(1 - n) g(i, j) + m(1 - n) g(i + 1, j)$$

$$+ n(1 - m) g(i, j + 1) + (mn) g(i + 1, j + 1)$$

with

$$i = \text{int}(r); m = r - i$$

$$j = \text{int}(s); n = s - j$$

Bilinear interpolation

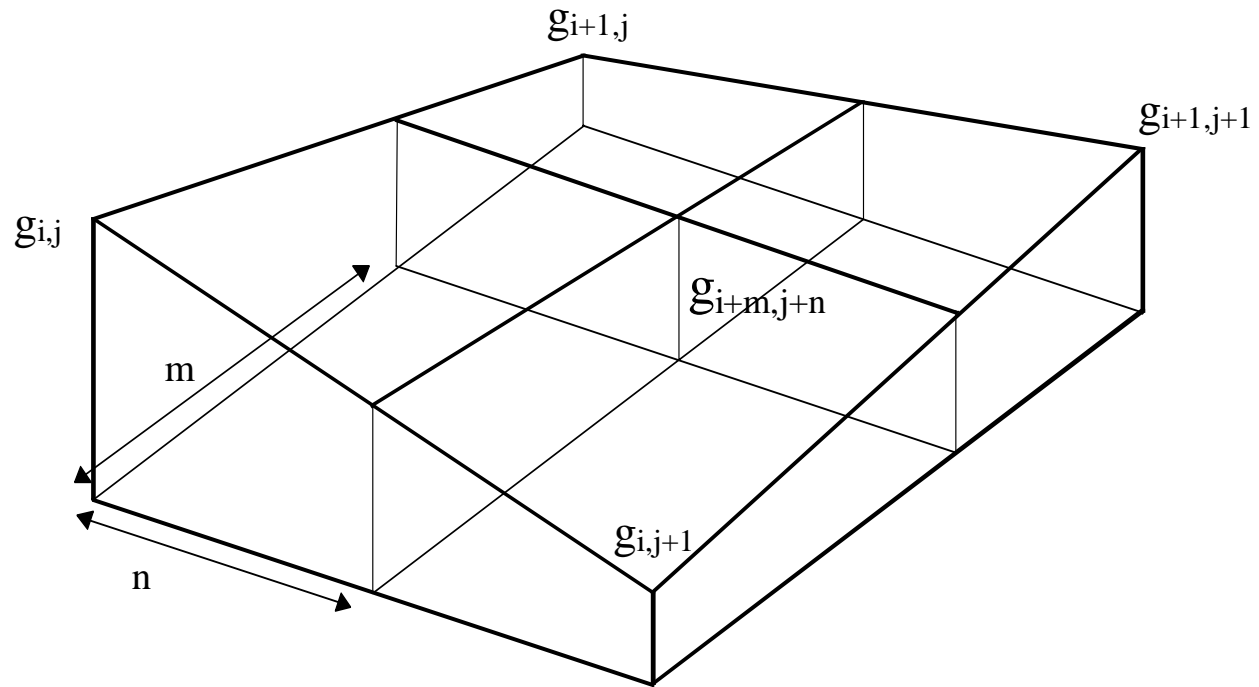

Bicubic interpolation

- The resampling accuracy can be further increased by modeling the image locally with a polynomial surface.
- Bicubic interpolation is more complicated and computationally extensive.
- The assignment of values to output pixels is done in the same manner as bilinear interpolation, except that the weighted values of 16 input pixels surrounding the location of the desired pixel are used to determine the value of the output pixel.

Bicubic interpolation

- The cubic interpolation with the 4 nearest neighbors in one dimension can be employed as:

$$h(x) = \begin{cases} 1 - 2|x|^2 + |x|^3 & 0 \leq |x| < 1 \\ 4 - 8|x| + 5|x|^2 - |x|^3 & 1 \leq |x| < 2 \\ 0 & |x| \geq 2 \end{cases}$$

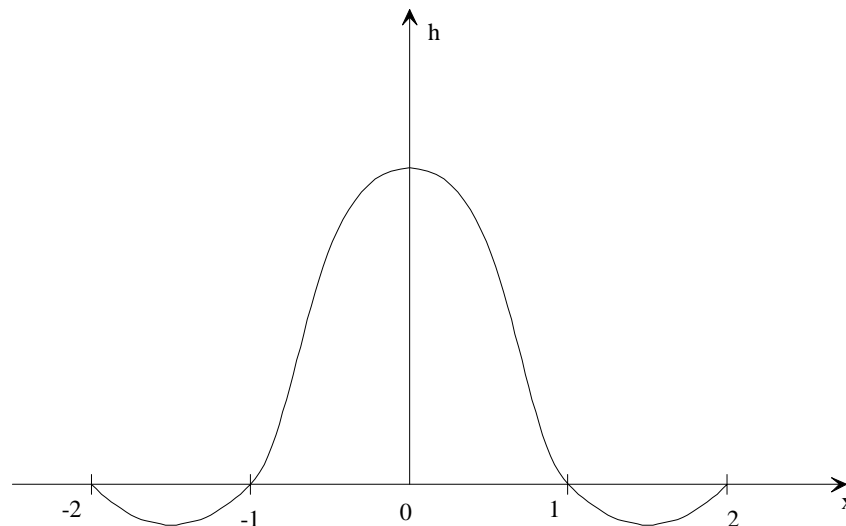

Bicubic interpolation

- A two dimensional implementation of the cubic interpolation is accomplished using a 4x4 pixel subimage about the resample location.
- First, a vertical line is passed through the resample location (see the figure).
- Next, four horizontal lines are made through the four rows of pixels.
- At the intersection of the vertical line and each of the four horizontal lines an interpolation is computed as follows:

Bicubic interpolation

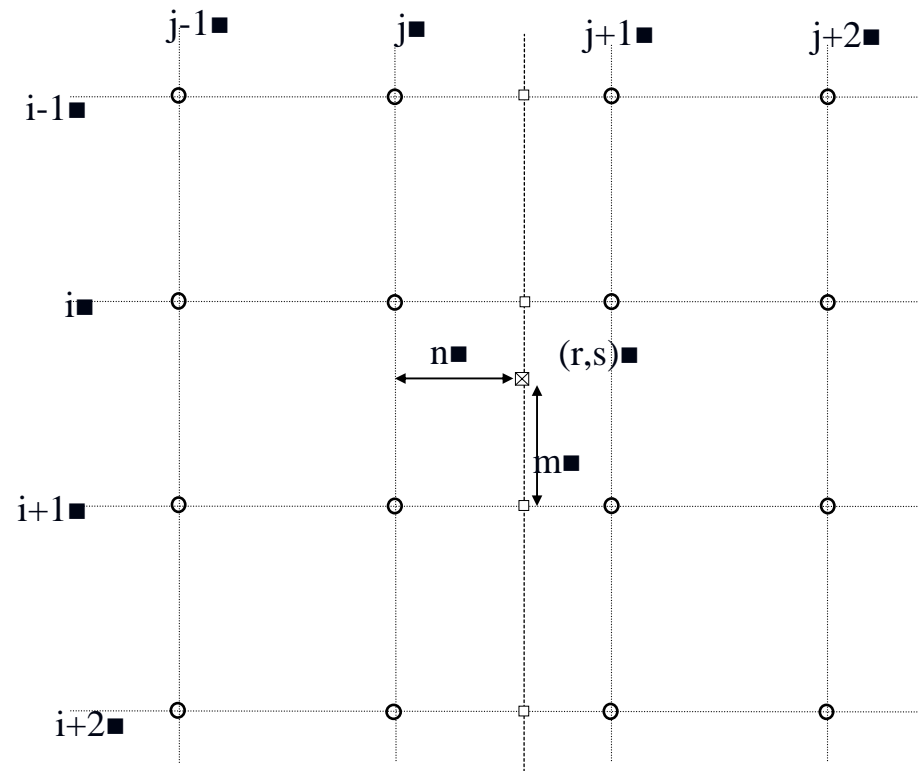

Bicubic interpolation

- At the intersection of the vertical line and each of the four horizontal lines an interpolation is computed as follows:

$$g(k, s) = -n(1-n)^2 g(k, j-1) + (1-2n^2+n^3)g(k, j) \\ + n(1+n-n^2)g(k, j+1) - n^2(1-n)g(k, j+2)$$

$$k = i-1, i, i+1, i+2$$

- Finally, these four interpolated values are reinterpolated along the vertical line to produce a value at the resample location using

$$g^T(r, s) = -m(1-m)^2 g(i-1, s) + (1-2m^2+m^3)g(i, s) \\ + m(1+m-m^2)g(i+1, s) - m^2(1-m)^2 g(i+2, s)$$

where $g(x,y)$ is the final interpolated value for the transformed output pixel at location x,y .

Digital photogrammetric products

- Main digital photogrammetric products:
 - Digital maps
 - Digital elevation models
 - Digital orthophotos

Digital Elevation Models

- Digital Elevation Models are one of the most common photogrammetric products used to represent the Earth's surface elevation as a set of points.
- Digital Elevation Models (DEMs) are digital files consisting of points of elevations, sampled systematically at equally spaced intervals.
- It represents the Earth's surface elevation digitally as an array of points
- It is called DTM when information is limited to ground elevation.
- It called DSM when information contains elevations of each point on ground or above ground (trees, buildings, etc..)

■ **DEM representation**

1. Regular raster grid describe a regularly sampled representation of elevation points
 - Regular raster grid have the geometry of an image (grey levels represent elevations.)
2. Triangular irregular networks (TIN)
 - Collecting sparse points elevations and then describing the surface by irregular triangles.
 - Irregular spaced sample points are measured with more points in areas of rough terrain and fewer in smooth terrain.

From Computer Desktop Encyclopedia
Reproduced with permission.
© 1999 Research Systems, Inc. and Rivix, LLC

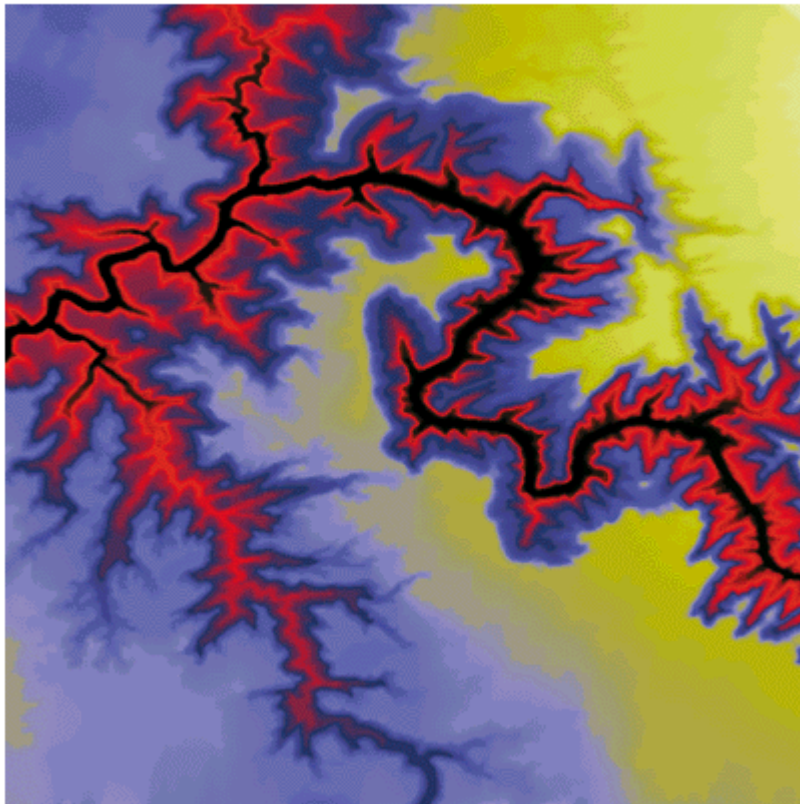

MTM -05/277 E: Tithonium Chasma (3.X Vertical Exaggeration)

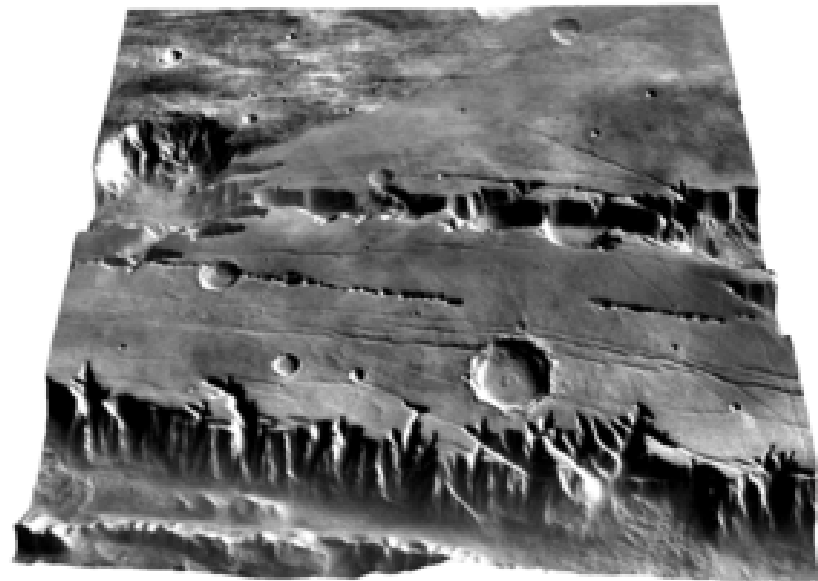

Creation of DEM

- DEM may be compiled in three different ways:
 - Photogrammetric compilation
 - Derivation from existing map products
 - Digital image matching

- Photogrammetric compilation
 - an operator looks at a pair of stereophotos through a stereoplotter and must move two dots together until they appear to be one lying just at the surface of the ground
 - Photogrammetric compilation generally produces the best results. (regular grid + breaklines)
 - Reliable but slow and expensive for large areas

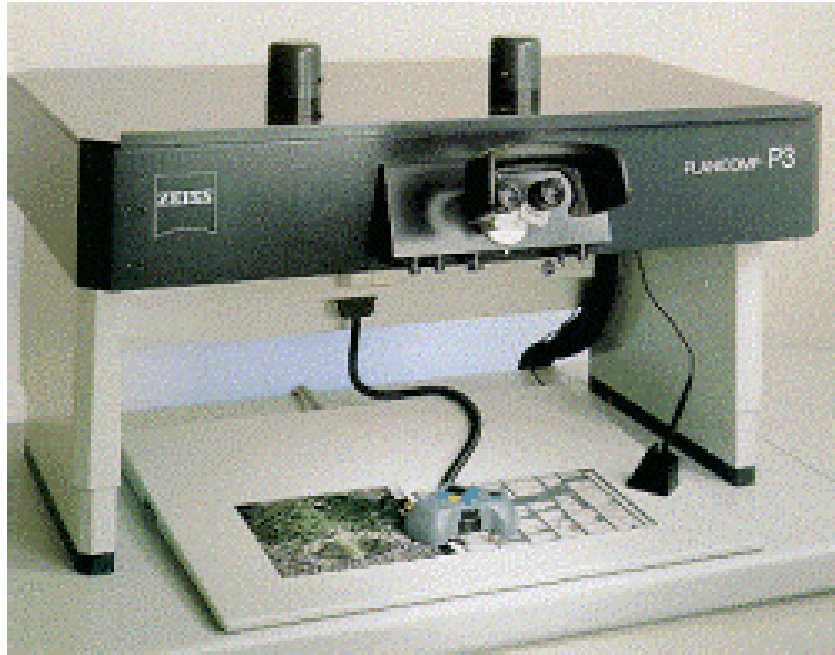

■Zeiss P-3

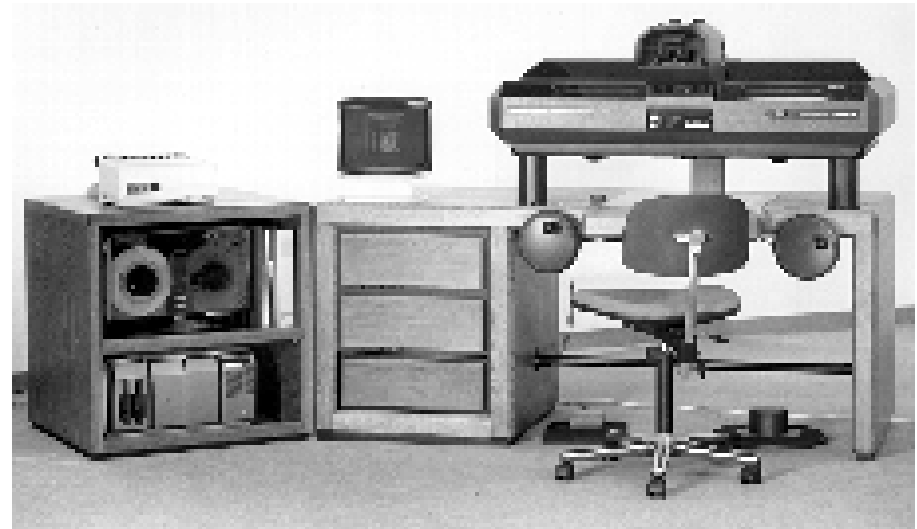

■Wild BC-1

- Derivation from existing map products
 - conversion of printed contour lines
 - existing plates used for printing maps are scanned
 - the resulting raster is vectorized and edited
 - contours are "tagged" with elevations
 - finally, an algorithm is used to interpolate elevations at every grid point from the contour data
 - Derivation from contour maps "smooths" the surface.

■ Digital image matching

- Automated system uses computer vision techniques to perform the operator's task of determining the ground surface elevation by matching corresponding points of two stereo images.
- automatically, an instrument calculates the parallax displacement of a large number of points
- It is extremely efficient and cost effective.
- Unfortunately, it does not work well in broken terrain or in areas of dense vegetation ground cover
- Fast and relatively inexpensive but fail in complicated areas.
- Manual editing of automated results is nearly always required.

- The choice of option is dependent upon the photo scale, ground cover, terrain characteristics, and accuracy.
- DEM collected on a grid of 2 to 3 mm on a diapositive and supplemented by breaklines will provide a good basis for orthorectification in most terrain.
- The greater the complexity of the terrain, the more dense the DEM must be.



Uses of DEMs

- Determining attributes of terrain, such as elevation at any point, slope and aspect
- Main input to orthoimage production.
- Can be used for GIS modelling.
- Finding features on the terrain, such as drainage basins and watersheds, drainage networks and channels, peaks and pits and other landforms
- Modeling of hydrologic functions, energy flux and forest fires

- Several factors play an important role for derived products-quality of DEM:
 - Terrain roughness
 - Elevation data collection (sampling density method)
 - Grid resolution or pixel size
 - Interpolation algorithm
 - Terrain analysis algorithm

Orthophotos

- An orthophoto is a photograph based on an orthophotographic projection, rather than the perspective projection of a regular frame photograph.
- An orthophoto is a photograph showing images of objects in their true orthographic positions.

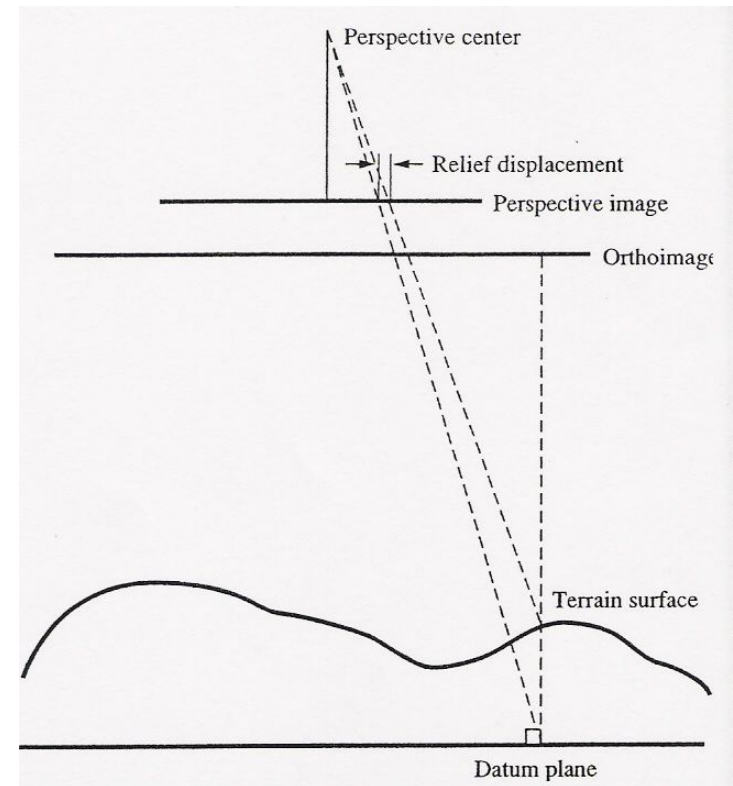

Orthophotos

- Orthophotos are “photomaps”
 - Like maps, they have one scale (even in varying terrain)
 - Like photographs, they show the terrain in actual details (not by lines and symbols)
- It is a product that can be readily interpreted like a photograph, but one on which true distances, angles, and areas may be measured directly.
- Orthophotos make excellent base maps for compiling data to be input to a GIS or overlaying and editing data already incorporated in a GIS.

Perspective Versus Orthogonal Projection



- Orthogonal Projection

- Perspective Projection

Perspective Versus Orthogonal Projection

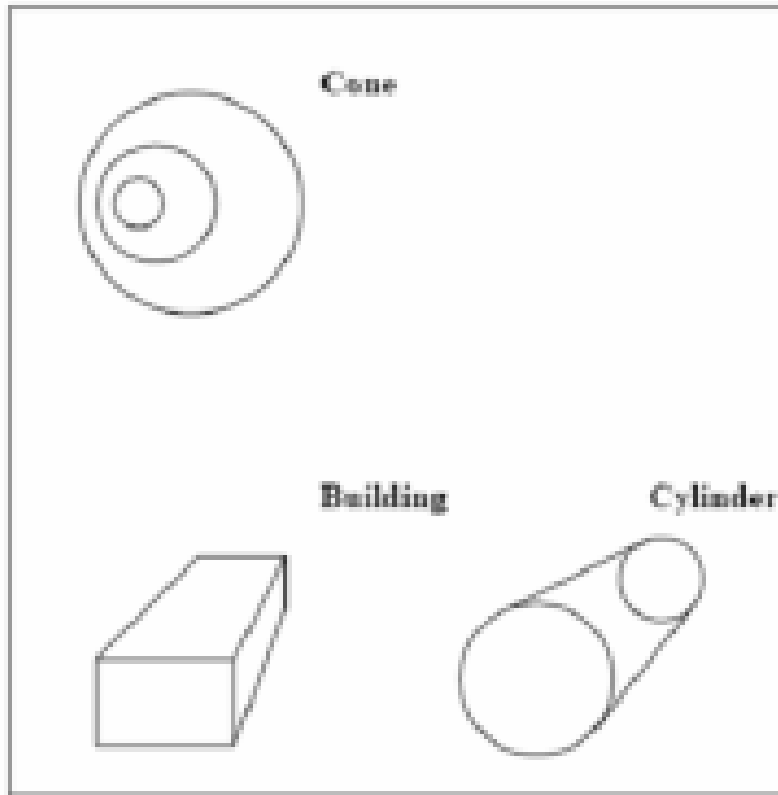

(A) Perspective projection

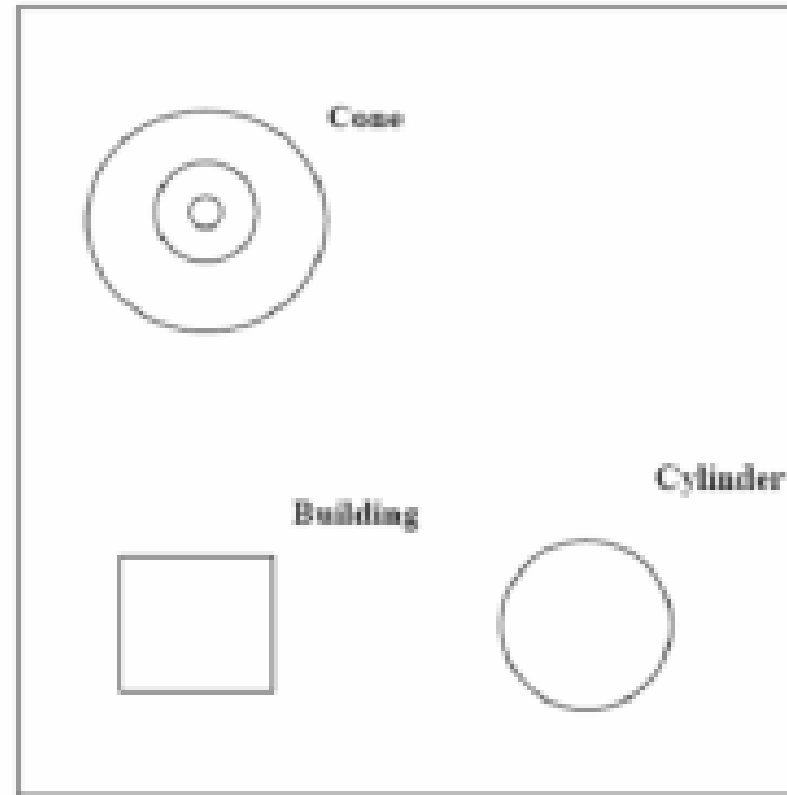

(B) Orthogonal Projection



Normal Ortho Mode

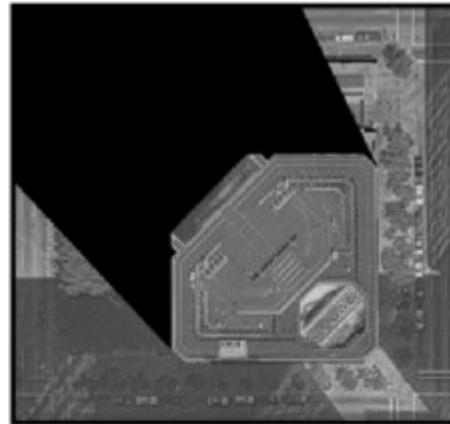

True Ortho Image 1

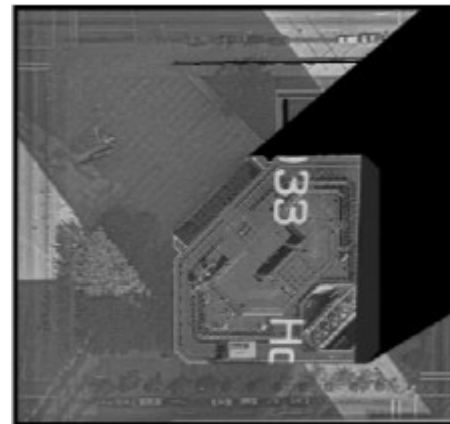

True Ortho Image 2

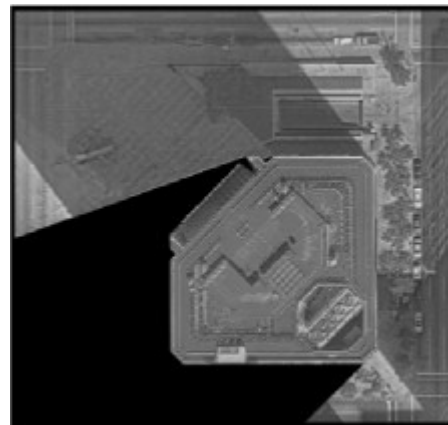

True Ortho Image 3

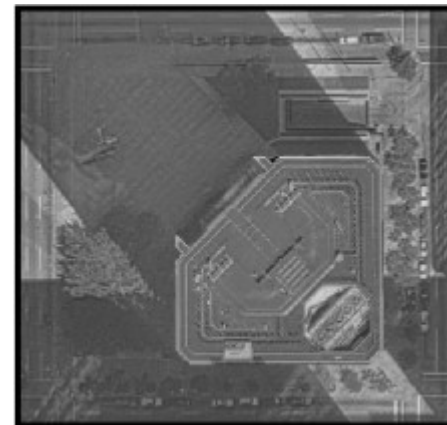

True Ortho Mosaic: Images 1, 2 and 3

Orthophotos

- Digital orthophoto is a comprised of a computer-compatible raster image which has been *analytically* rectified to eliminate distortions arising from:
 1. the attitude of the camera at the time of exposure
 2. The image displacement occurring as a function of relief
 3. the camera system
- “Analytical” rectification simply means that the process is entirely mathematical and is fully implemented in software.
- The only optical-mechanical components in the process take place in the scanning and hardcopy output phases.

Orthophotos

- Orthophotography has been in existence for many years in hardcopy form.
- It is compiled by means of optical-mechanical instrumentation and the final image is exposed on photographic film.
- The process was conceived in the 1900's, became operational in the 1950's, but did not achieve practicality until the late 1960's.
- Orthophotos are produced from stereopairs of aerial photographs through the process of differential rectification.

Orthophotos

- Gigas-Zeiss Orthoprojector GZ1
- Uses components of C-8 Stereoplanigraph
- Exposure slit moves in strips across the projection surface
- Scale of image continuously varied according to the relief by means of z-motion

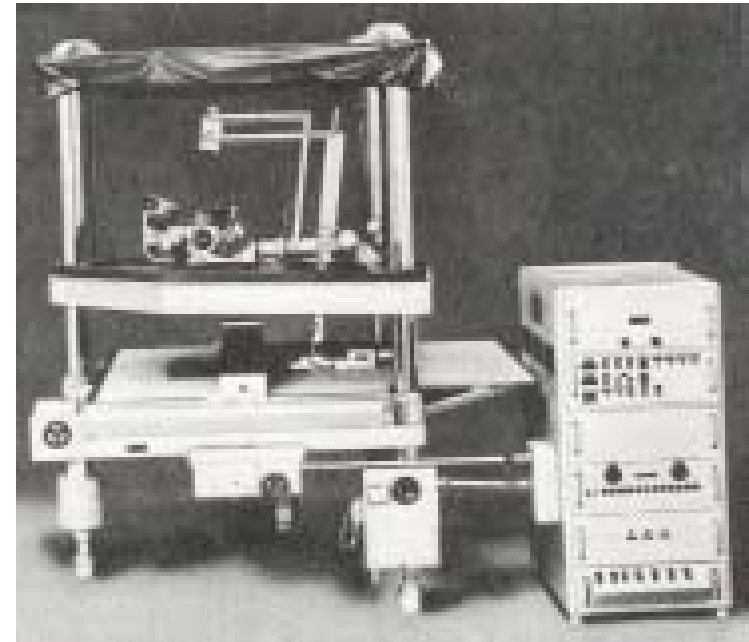

Orthophotos

- This term “**rectification**” has its origin in the concept that the image is rectified in numerous very small areas and then “assembled” into the composite product.
- The geometry of the image is changed from that of conical bundle of rays to parallel rays which are orthogonal to the ground and to image plane.
- The quality of the analog orthophoto is a function of many factors:
 - The stereoscopic acuity of the operator
 - The scanned speed
 - The width of the strip
 - The character of the terrain
 - The quality of the original photography, ground control, and the aerial triangulation.

Orthophotos

- A digital orthoimagery is analogous to the conventional product described above in theory, but is far superior in execution.
- The two most significant traits of this imagery relative to analog orthophoto are geometric fidelity of the image and the fact it is digital.
- The inputs of the process are four:
 - Aerial photography
 - Aerial triangulation results
 - Digital elevation model
 - Camera calibration report.

Orthophotos

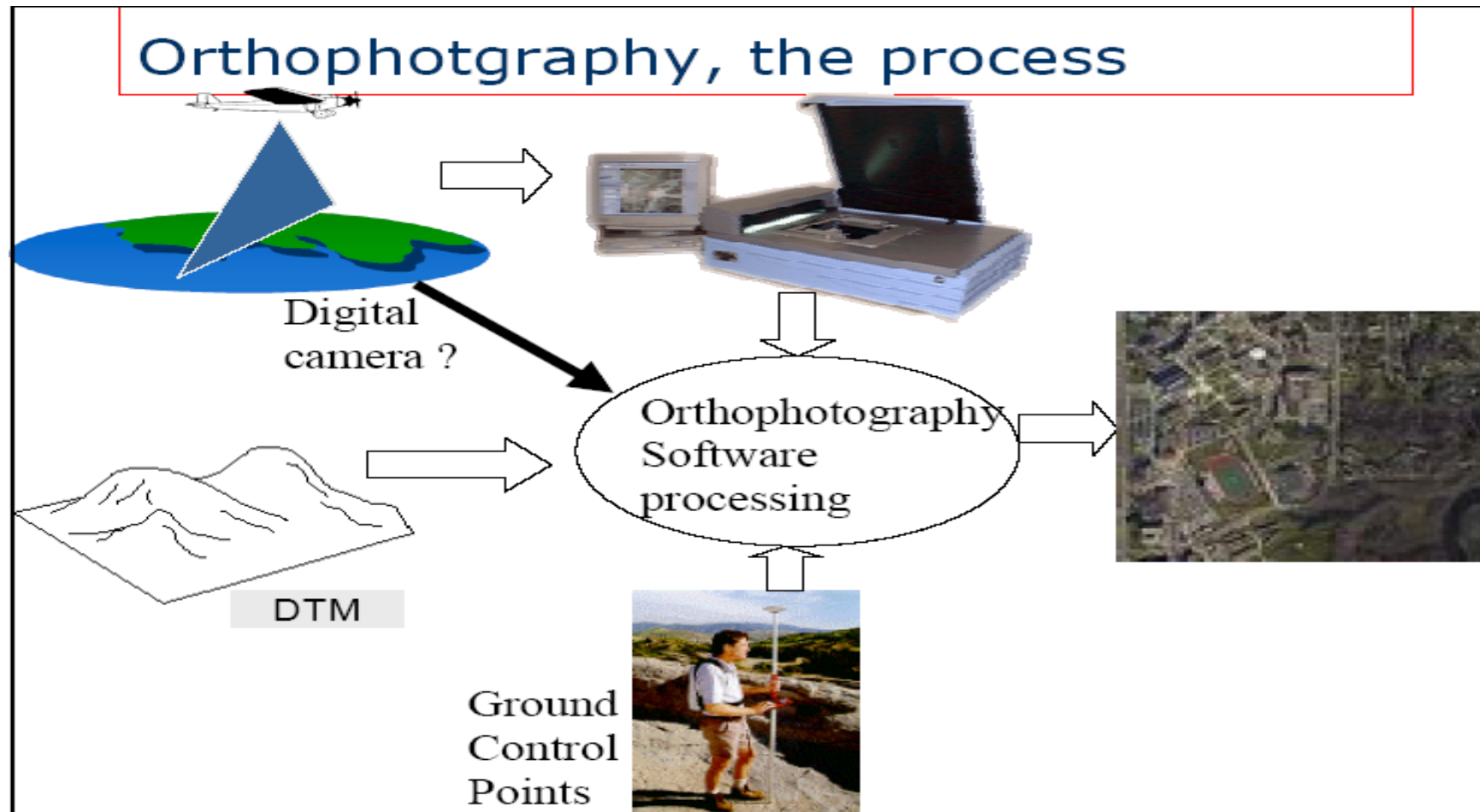

Orthophotos

- DEM information is then used to remove the elevation effects from the perspective image by projection.
- Orthoimages are often produced from more than one source image to obtain the required coverage for the final product.
- Selecting only the central portions of images minimizes the relief displacement shown by buildings or elevated objects.
- Another way to reduce the relief displacement in images intended for orthoimage production is to use lenses with longer focal lengths than the standard 152-mm lens.

Orthophotos

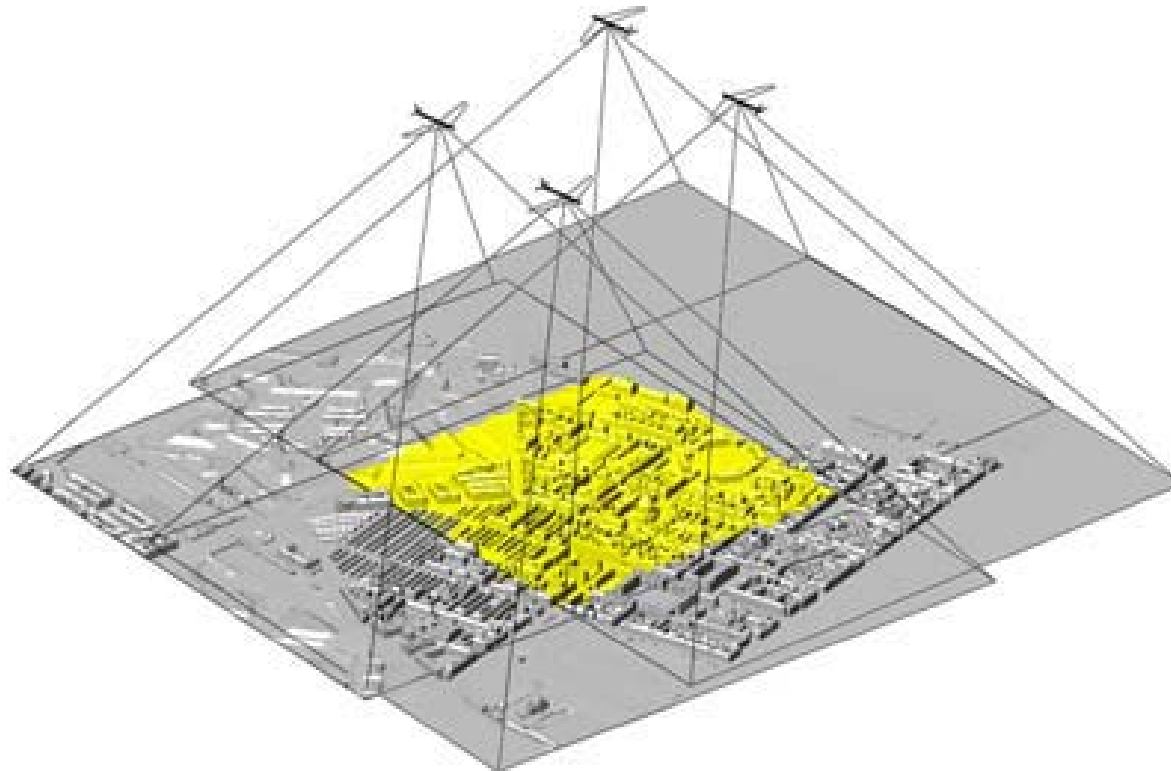

Approaches of generating an orthoimage:

- Forward projection:
 - Pixels in the source image are projected onto the DEM and their object space coordinates are determined.
 - The object space points are then projected into the orthoimage.
 - This results in irregularly spaced points in the orthoimage.
 - It requires interpolation to produce a regular array of pixels.

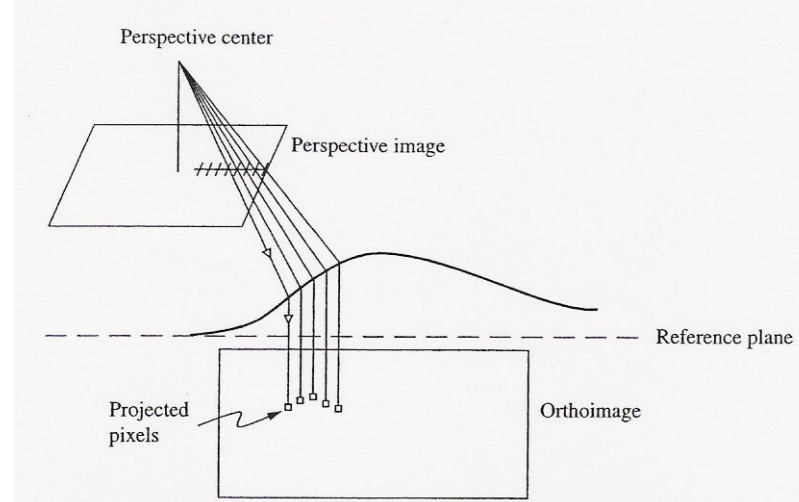

- Backward projection:

- The object space X, Y coordinates corresponding to each pixel of the final orthoimage are calculated.
- The elevation Z at the X, Y location is determined from the DEM.
- This X, Y, Z object space coordinates are projected into the source image to obtain the gray level for the orthoimage pixel.
- Since the projected object space coordinates will not fall exactly at pixel centers in the source image, interpolation or resampling must be done in the source image.

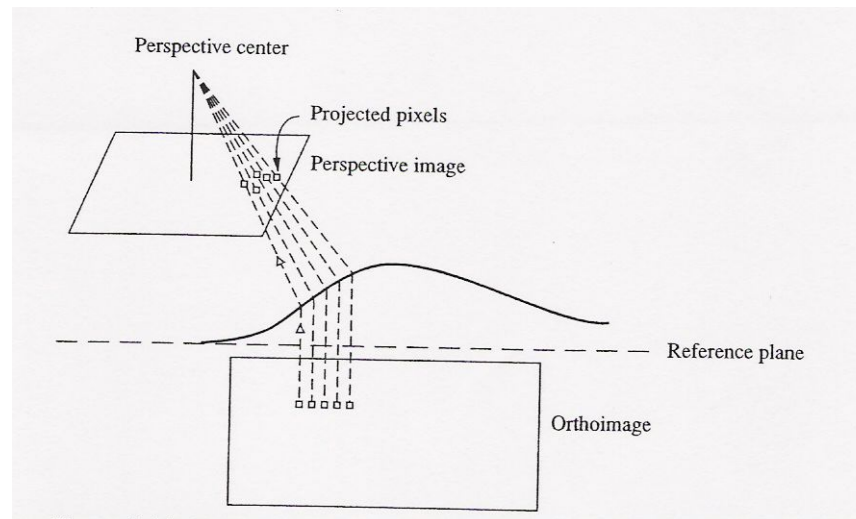

Orthophotos

- The accuracy of a digital orthoimagery is a function of:
 - The quality of the photography
 - The control
 - The photogrammetric adjustment
 - The DEM.

Advantages of digitally produced orthophotos

- the geometric accuracy is basically higher since a very close mesh of points is used to approximate the ground surface.
- Image content can be modified quite simply by contrast manipulation of the densities and color.
- An elegant matching of densities at the edges of neighboring images in an orthophoto mosaic can be achieved.
- Further improvements, such as edge enhancement, can be introduced by appropriate filtering.
- The digital orthophoto can be stored as a level of information in a geographic information system.
- Digital orthophotos can be analyzed by the methods of multispectral classification, image segmenting, pattern recognition, etc.

