

CEN 444

Computer networks

Associate-Professor: **Mohamed M. Abd-Eldayem**

Dept. of Comp. Engineering

College of Computer and Information Sciences (CCIS)

King Saud University

Email: mdayem@ksu.edu.sa

Chapter Outline

I. Communication Systems

1. Centralized
2. Distributed

II. Intro. To Computer Networks

1. Needs and Definition
2. Objectives
3. Network Essentials
 1. Types of computer networks
 2. Network layout
 3. Network technologies
 4. Client-server and peer-to-peer models
4. Network features
 1. Components
 2. Classification of computer networks
 3. protocols
5. Internet technology

I. Communication Systems

➤ Diversity of Applications

- Information (traffic) type Signal, data, audio, video
- Processing type request-reply, real time, secured
- Required performances rapidity, reliability, QoS : Quality of Service

➤ Types of Communication Systems

- Centralized Communication Systems
- Distributed Communication Systems

I. Communication systems

1. Centralized communication systems

Central unit (processor)

- Queuing tasks to be executed,
- Manage these tasks,

sequentially, concurrent, mixed

Disadvantages

- high cost (performance)
- bottleneck (Center Point of Failure)
 - *Incapable to support requests,*
 - *Incapable to offer desired performances.*

I. Communication systems

2. Distributed Systems

- A distributed system is a set of computer processes that appear to the user as a single system.
- The distributed system must coordinate all of these processes.
- Distributed systems are implemented using middleware that creates a communication topology.

II. Intro. to Computer Networks

- Evolution of electronic devices,
- Apparition of computer science

➔ Telecommunications: new structure

Last model: single computer

- not valid,
- doesn't satisfy all the processing needs.

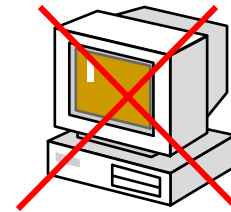

Current model: set of computers

- Separated,
- Interconnected,
- Executing different tasks.

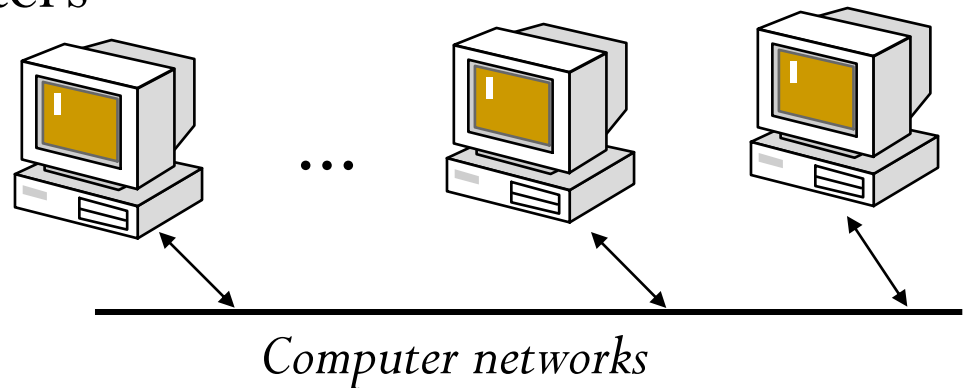

1. What is a Computer Network?

- **Computer Network** is a set of computers connected together using a communication system.
- **The purpose of computer network** is for computers to communicate and share files.
- **Data Networks** is a digital networks used to send data between computers.
- Interconnection may be within a medium (networking medium) capable of communicating information.
- **Medium (Media)**: is a physical medium in which data is transferred, for examples:
 - Copper Wire (**UTP**)
 - Lasers
 - Microwave
 - Satellite link
- Example of Networks: **Ethernet**

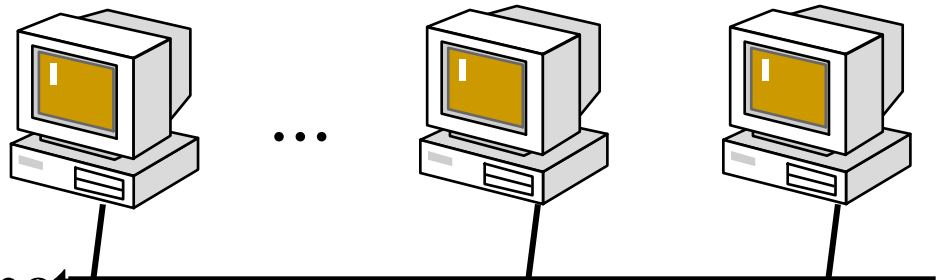

1. What is a computer network?

Definition. Two or more computers or communication devices connected by transmission media and channels and guided by a set of rules for communication purposes that allow users to communicate with each other and share applications and data.

Hardware:

- *Computer*
- *Network card*
- *Routers*
- *Modem ...*

Media:

- *Cable*
- *Wire*
- *Microwave ...*

Components of a Computer Network

Software:

- *Network OS*
- *Utilities ...*

Network Design:

- *Physical layout*
- *Logical layout*

2. Why use a network?

1. Exchange information

2. Share available resources

- Data, messages, graphics ...
- Applications ...
- Devices, e.g., hard drives, backups, printers, modems, fax machines ...

Resources become available regardless of the user's physical location

2. Why use a network?

3. Load Sharing

- Jobs processed on least crowded machine

4. Centralized administration

- Installing and upgrading application software

5. Communication and collaboration

- Teleconferences, Human-to-Human Communication
- e.g., Telephone, IP telephony

6. High Reliability

- Alternative source of supply (multiple copies)

3. Network Categories

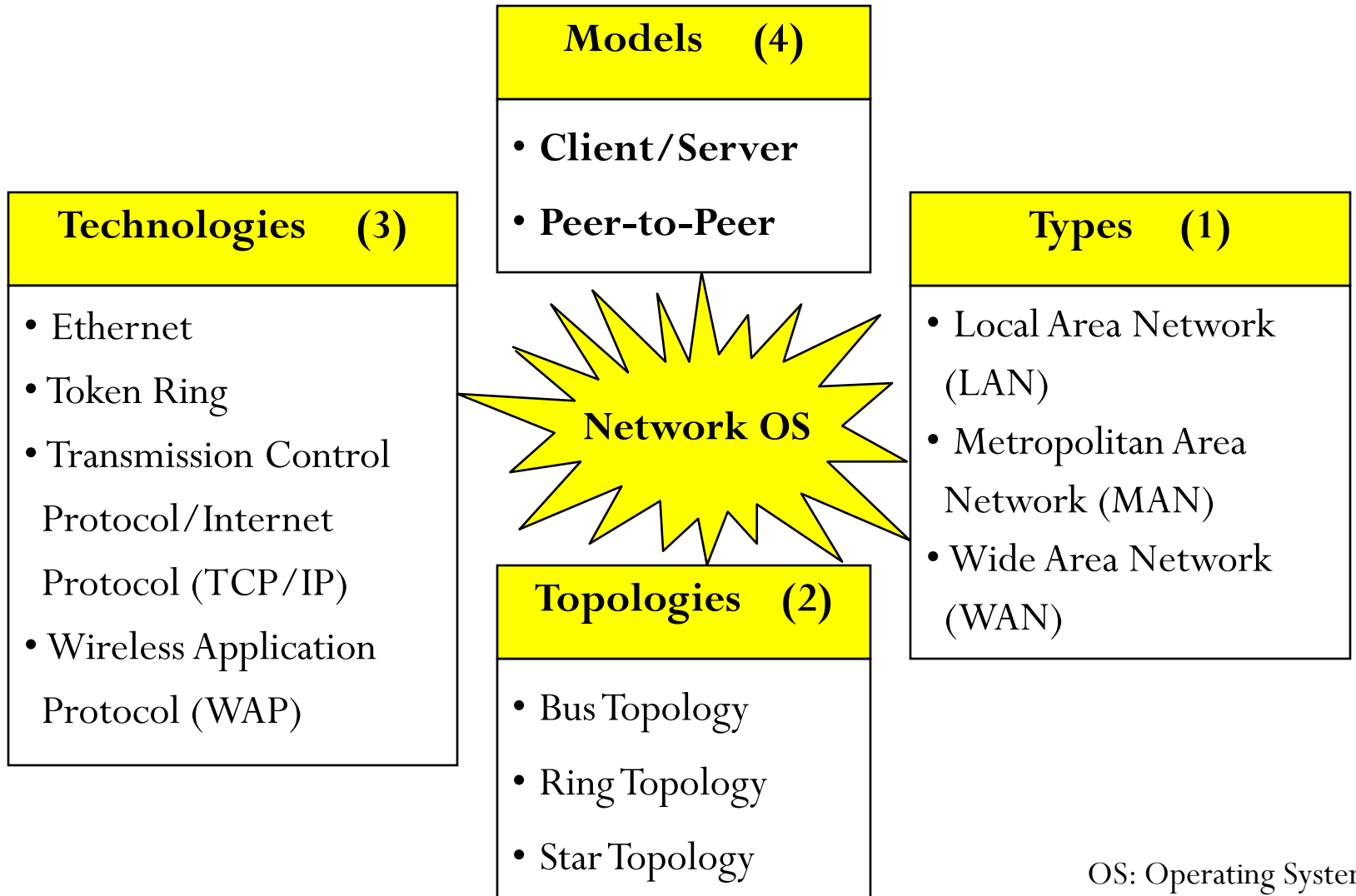

OS: Operating System

3.1. Three major types of networks

- **Local Area Network (LAN)**
 - Serves users within a confined geographical area (usually within a mile).
- **Metropolitan Area Network (MAN)**
 - Covers a geographic area the size of a city or suburb. The purpose of a MAN is often to bypass local telephone companies when accessing long-distance service.
- **Wide Area Network (WAN)**
 - Covers a wide geographical area, such as a state, a country, or many countries. Examples: Internet.

Local Area Network (LAN)

- An individual network usually spans a single geographical area,
- Providing services and applications to people within a common organizational structure, such as a single business, campus or region.
- A LAN is usually administered by a single organization.
- The administrative control that governs the security and access control policies are enforced on the network level.

Wide Area Network (WAN)

- When a company or organization has locations that are separated by large geographical distances, it may be necessary to use a telecommunications service provider (TSP) to interconnect the LANs at the different locations.
- Telecommunications service providers operate large regional networks that can span long distances.
- Individual organizations usually lease connections through a telecommunications service provider network.
- These networks that connect LANs in geographically separated locations are referred to as Wide Area Networks (WANs).
- Although the organization maintains all of the policies and administration of the LANs at both ends of the connection, the policies within the communications service provider network are controlled by the TSP.

Other Distinctions

- Metropolitan Area Network (MAN)
 - Single urban area (city and its suburbs)
 - Faster than long-distance WANs
 - Still slower than LANs
- Personal Area Network (PAN)
 - A person's body or desk area
- Storage Area Network (SAN)
 - To link servers to shared storage devices
- Wireless Networks (WLAN)

3.2. Network Topologies

- ❖ **Topology:** The geometric arrangement of devices on the network. In general, devices can be arranged in a:
 - Star
 - Bus
 - Ring
 - Hierarchical
- ❖ **Logical Topology:** The map of devices on a network and how they communicate with one another, shows the flow of data on a network

3.2.1. Network Topologies: Star

This arrangement connects all the network's devices to a central host computer (hub), through which all communications must pass.

- Adding and removing device in the hub is trivial
- All information must be sent through the hub to the devices
- Hub provides single point of inspection of all traffic through the topology
- If the hub fails then the entire system fails (Center point of failure)
- The hub can become overloaded and the system will experience slowdown

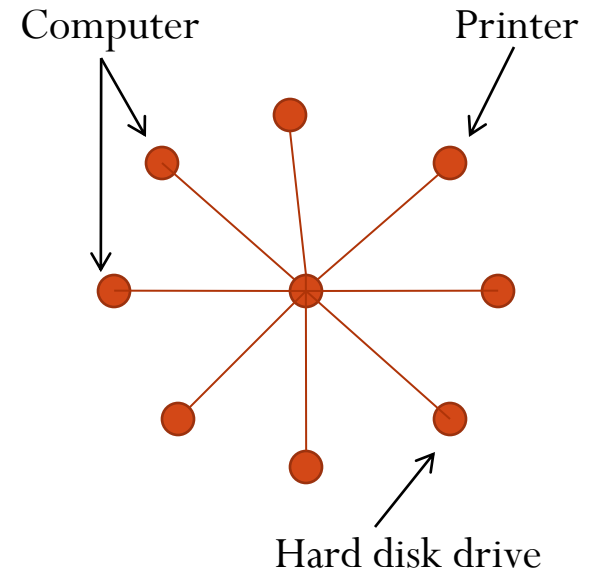

3.2.2. Network Topologies: Bus

A single channel connects all communications devices.

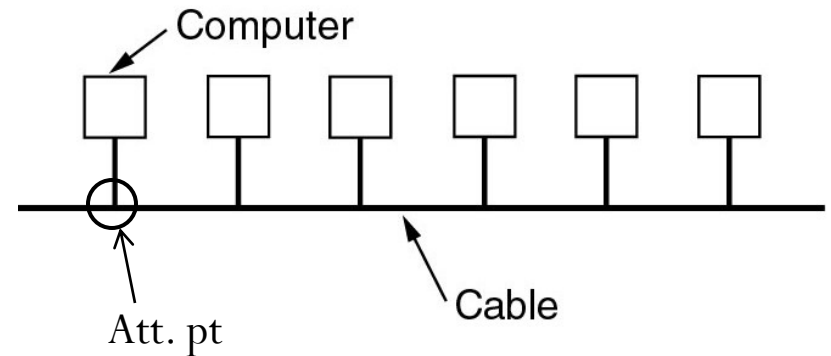

- LAN (1 Km)
- Attachment unit to the bus is necessary for interconnection
- Limited number of computers

Only one computer allowed to transmit information (master)

broadcasting topology → arbiter: access control mechanism

3.2.3. Network Topologies: Ring

This arrangement connects the network's devices in a closed loop.

- Involves only one connection between any two nodes.
- Successive point-to-point links

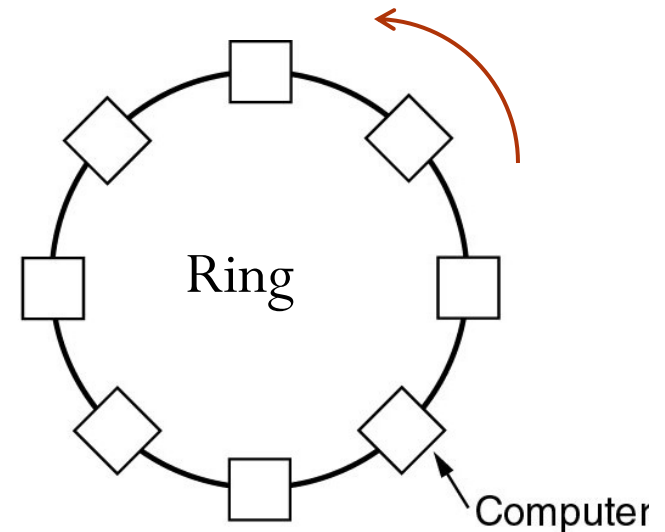

In a classic ring topology, messages are passed from node to node around the ring in a specific direction.

3.2.4. Network Topologies: Hierarchical

Tree

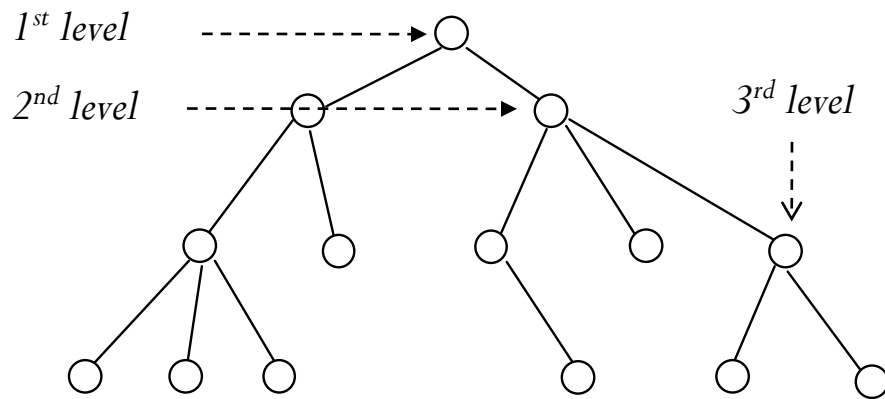

Mesh

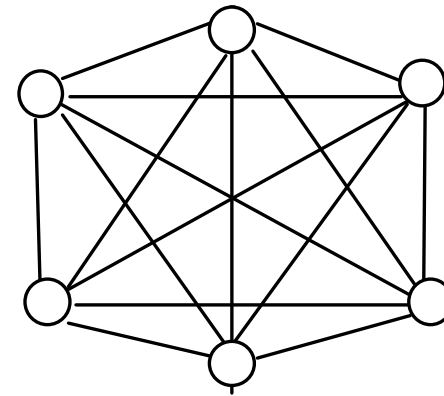

- A Tree topology consists of root node that is connected to second-level nodes.
- The second level nodes are connected to a 3rd level nodes...

- Full mesh topology: Connects all nodes together with a direct connection.
- Partial mesh topology: Only a subset of nodes are connected together.

3.3. Network Technologies

Ethernet

- Can be used in star topology and tree topology
- Most popular: inexpensive, easy to install and maintain.

Token Ring

- Can be used in ring topology
- Token-passing scheme to prevent collision of data.

TCP/IP

- Uses packet switching technique for data transmission;
- Commonly used for Internet applications.

WAP

- Allows wireless devices to access the Internet and WWW;
- Meets increasing demands for wireless Internet access.

3.4. Network Models (1)

Client/Server Model

Microcomputer users, or *clients*, share services of a centralized computer called a *server*.

Client: Get services

Server: Provide services

The client-server model involves requests and replies.

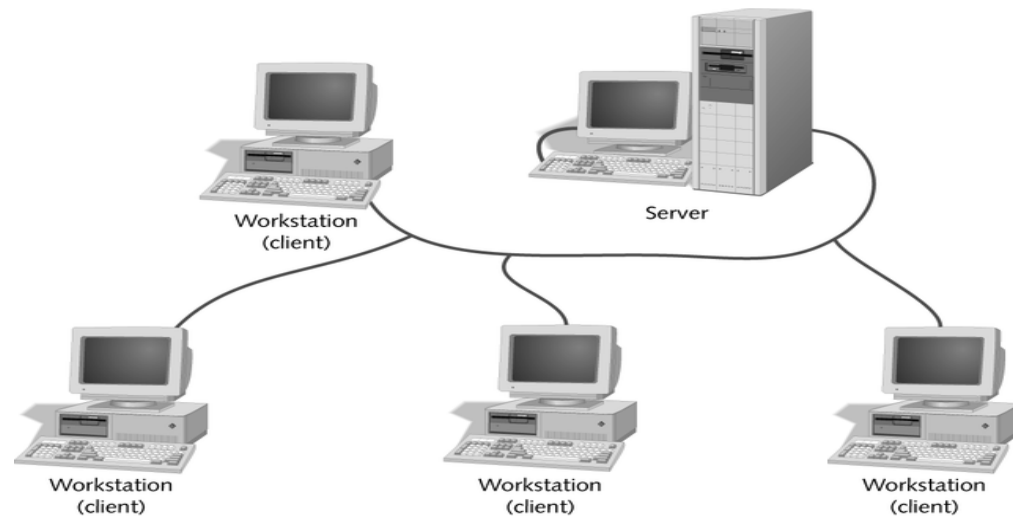

Principle:

1. Message from client (request to server)
2. Server →
 - achieves task(s)
 - returns reply (result)
 - ensures reliability

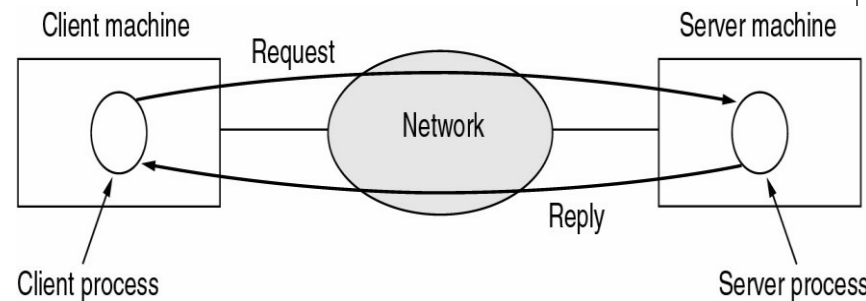

3.4. Network Models (2)

Client/Server Model

Pros:

- Very secure
 - Centralized servers easy to manage
 - Physically centralized
 - Secure OS
- Better performance
- Centralized backups
- Reliability
 - Simple job to do plus built in redundancy

Cons:

- Require professional administration
- More hardware intensive

3.4. Network Models (3)

Peer-to-Peer Model

Computers on the network communicate with each others as equals and each computer is responsible for making its own resources available to other computers on the network (without having a central server).

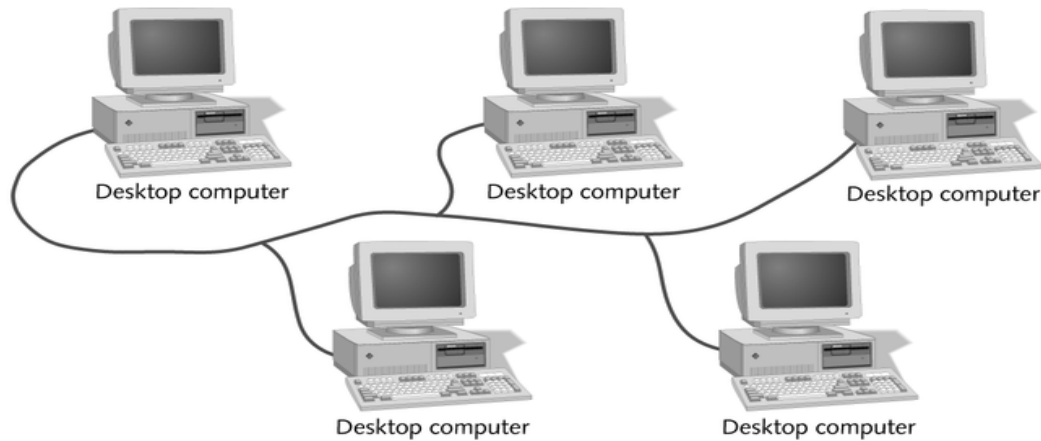

3.4. Network Models (4)

Peer-to-Peer Model

Pros:

- Uses less expensive computer networks
- Easy to administer
- No NOS (network operating system) required

Cons:

- Individual user performance easily affected
- Not very secure (no guarantee others will administer their resources properly)
- Hard to back up.

4. Network features

- Components (devices)
- Classification of computer networks
- Protocols

4.1. Components of a Network (1)

- **Server**
 - A computer that provides services to other networked computers
- **Client**
 - A computer in a client/server relationship, It gets services from server
- **Media**
 - is a physical medium in which data is transferred
- **Hardware/Software**
 - Network card, router, modem, hub, programs, soft tools, utilities ...
- **Data**
 - Files to be shared by network computers
- **Resources**
 - Peripherals, e.g., printers, to be used by network computers

4.1. Components of a Network (2)

Media of Networking

- Coaxial cable
- Twisted pair cable
- Fiber optic cable
- Microwave
- Satellite link
- Cellular phones

4.1. Components of a Network (3)

Transmission Modes

- **Simplex Mode.** One way of transmission
- **Half-Duplex Mode.** provides both directions, but only one direction at a time (not simultaneously).
- **Full-Duplex Mode.** allows transmission in both directions, simultaneously.

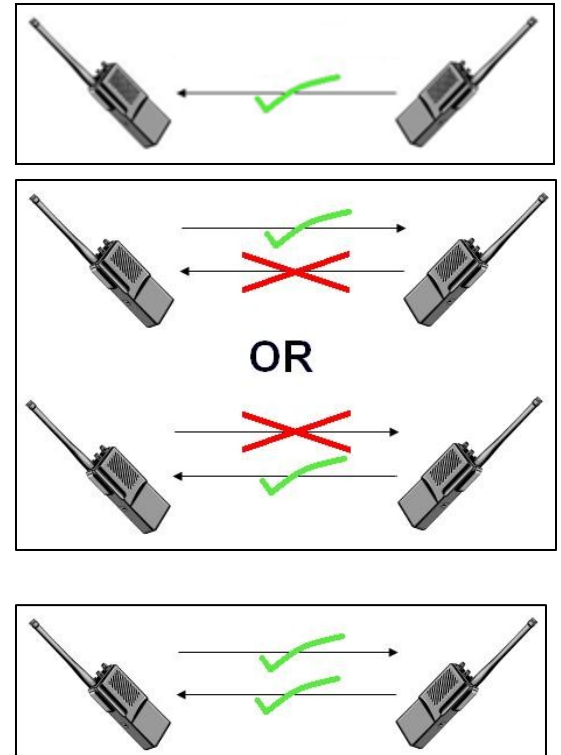

4.1. Components of a Network (4)

Networking Hardware

- Workstations
- Servers
- Hubs
- Switches
- Bridges
- Routers
- Gateways

4.1. Components of a Network (5)

Networking Hardware

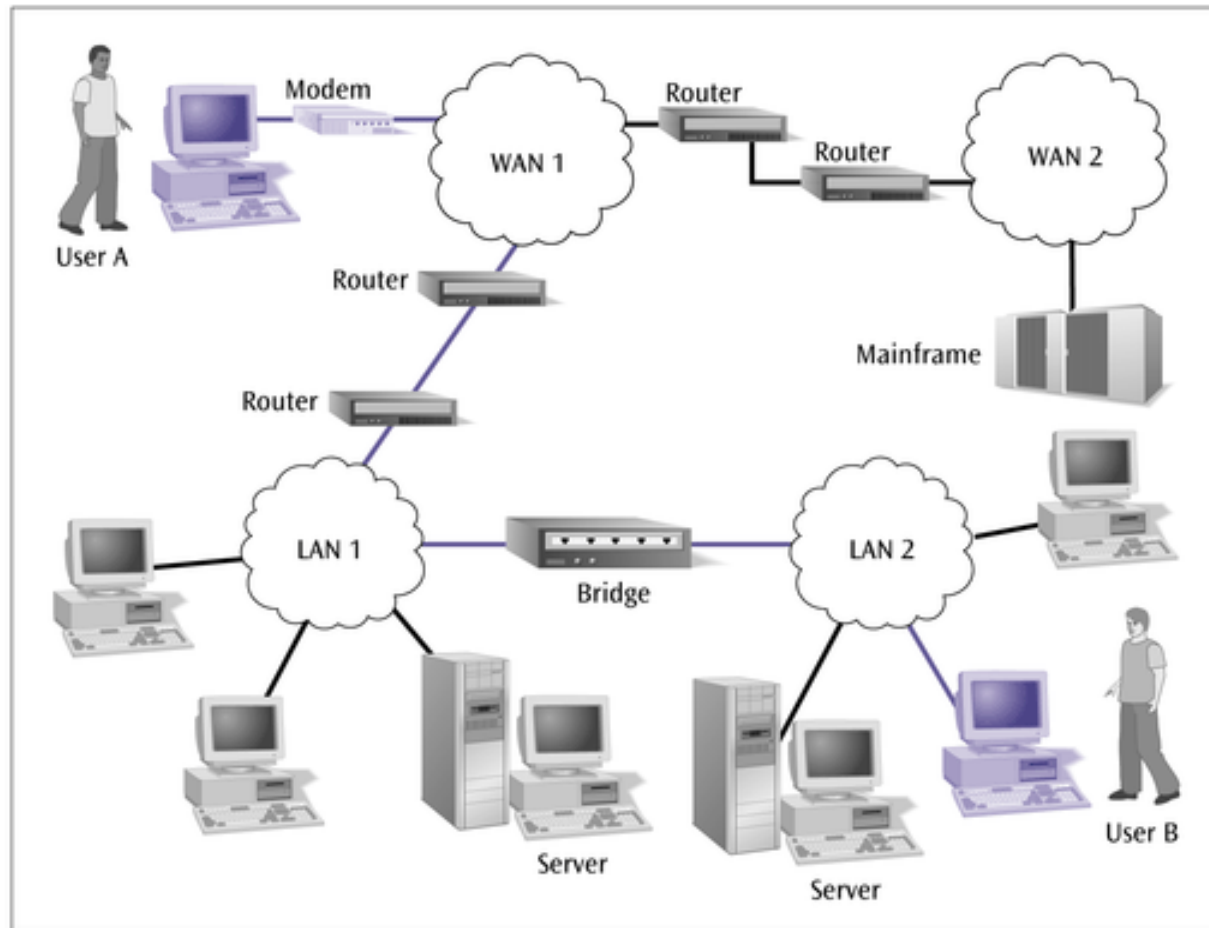

4.2. Classification of computer networks (1)

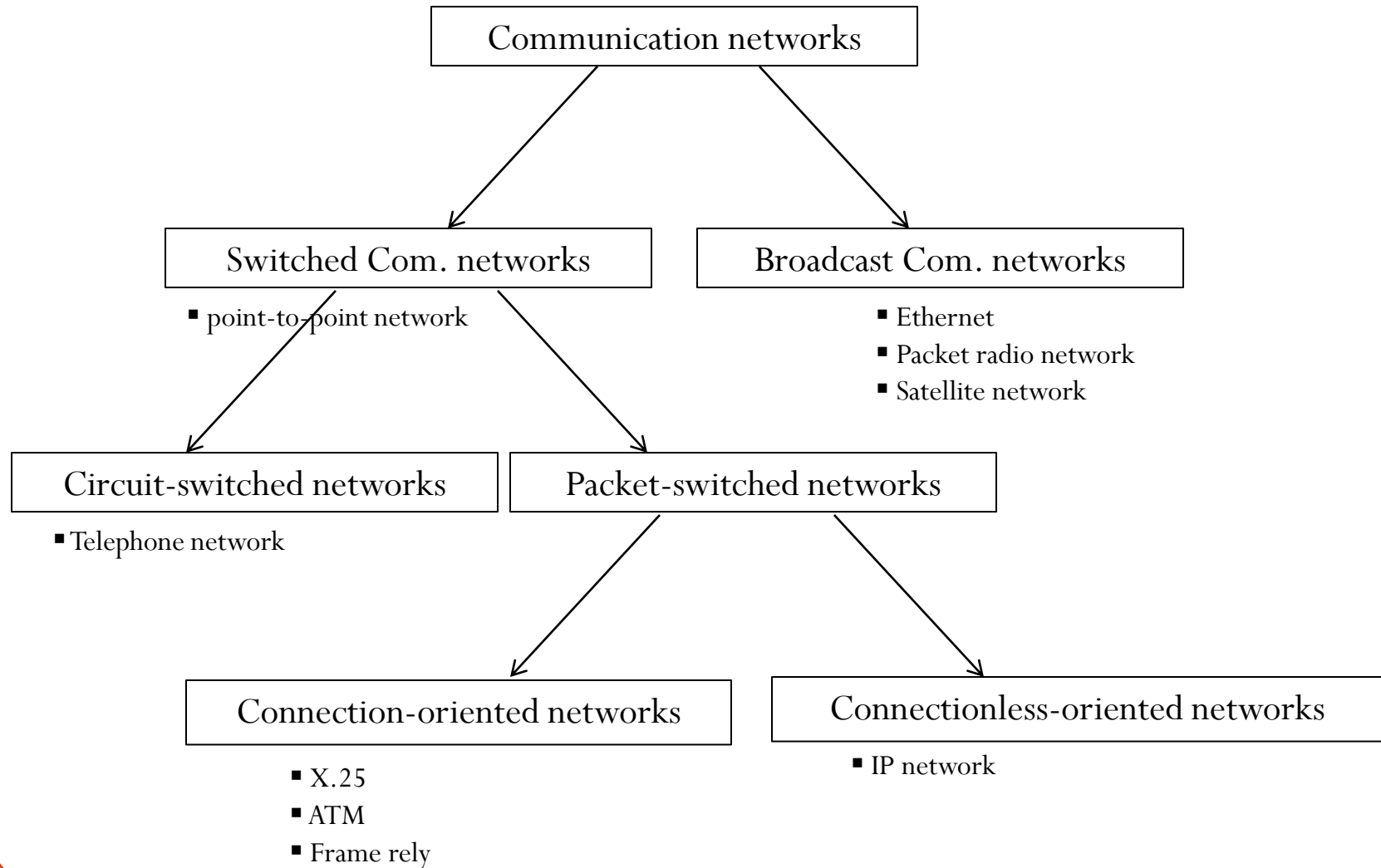

4.2. Classification of computer networks (2)

Broadcast communication networks

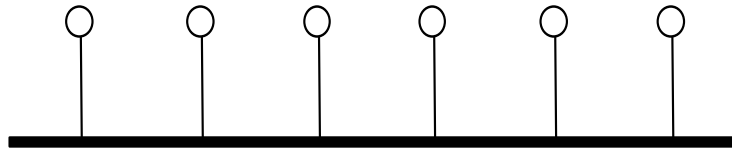

Bus

Multi-access Ethernet

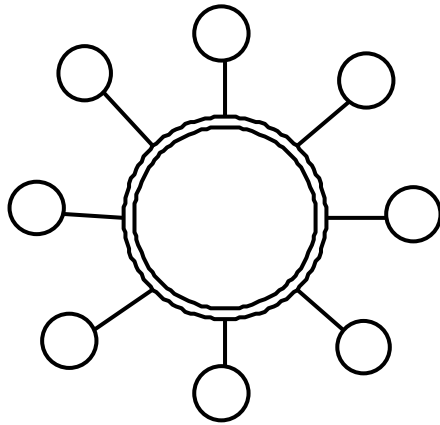

Ring

Satellite

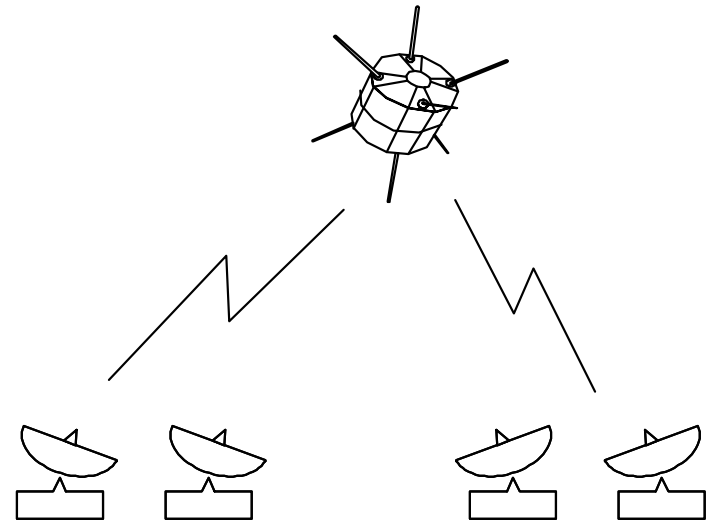

Satellite network

4.2. Classification of computer networks (3)

Switched (Point-to-point) communication networks

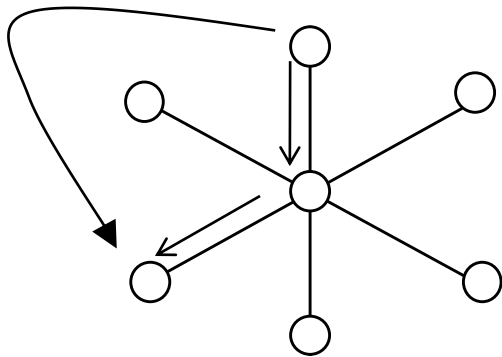

Star

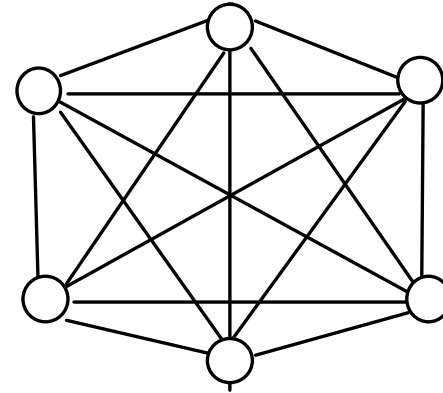

Mesh

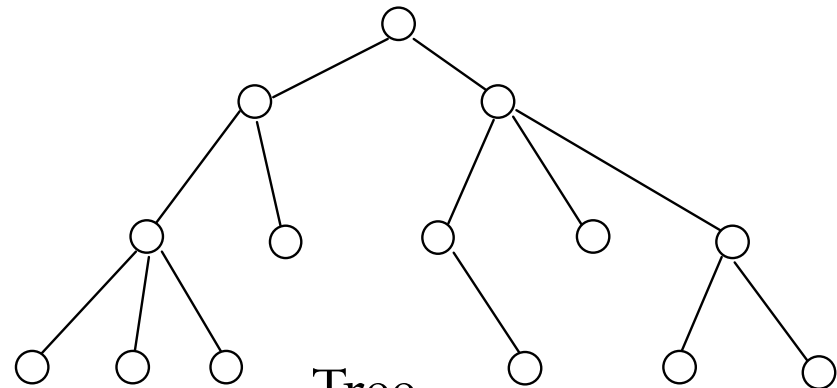

Tree

4.2. Classification of computer networks (4)

Connection-oriented networks

In order for two users to communicate a circuit or a connection has to be first established by the network. Specifically, the following three phases are involved:

- Connection establishment,
- Data transfer, and
- Disconnection.

Examples: ATM, Frame Relay, MPLS

4.2. Classification of computer networks (5)

Connection-oriented networks

Handshaking phase before transmitting data = Signaling step

Get agreement (rate, maximal data size, loss rate, QoS...)

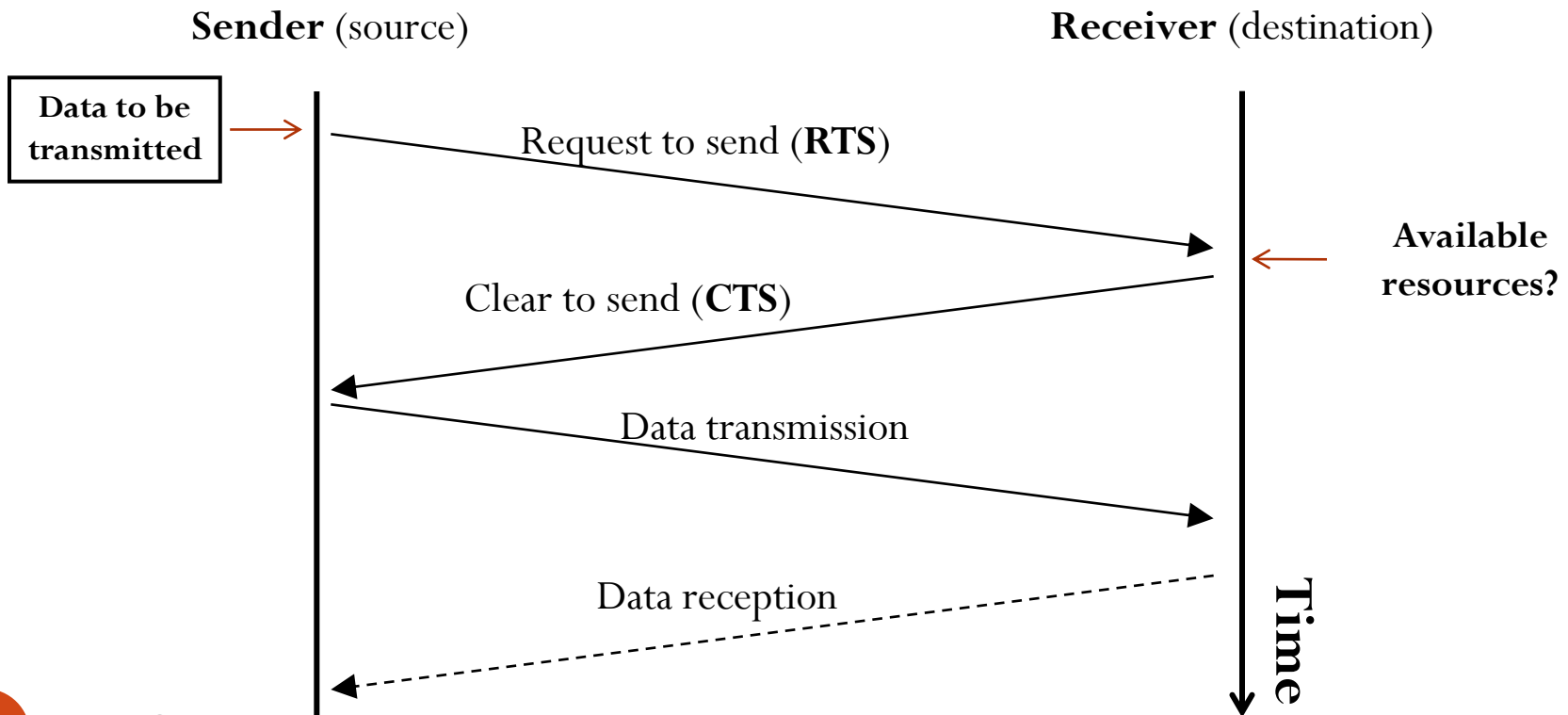

4.2. Classification of computer networks (6)

Connectionless-oriented networks

- In an IP network, a user can send packets to a destination without having to set up a connection first, i.e., without informing the network prior to transmitting them.
- This simplifies the network, as there is no need for a special signaling protocol.

4.3. Protocols (1)

Basically, a **protocol** is an agreement between the communicating parties on how communication is to proceed. It includes the rules and encoding specifications for sending data. The protocols also determine whether the network uses a peer-to-peer or client/server model.

The key elements of a protocol are:

- **Syntax.** includes such things as the data format, coding and signal levels.
- **Semantics.** includes control information for co-ordination and error handling.
- **Timing.** includes speed matching and sequencing.

4.3. Protocols (2)

New

Layered Network Architecture (model in layer)

- To reduce their design complexity,
 - Most networks are organized as a stack of layers or levels,
 - Each one built upon the one below it.
- The number of layers, the name of each layer, the contents of each layer, and the function of each layer differ from network to network.
- The purpose of each layer is to offer certain services to the higher layers, shielding those layers from the details of how the offered services are actually implemented.
- In a sense, each layer is a kind of virtual machine, offering certain services to the layer above it.

4.3. Protocols (2)

Layered Network Architecture (model in layer)

- **Network architecture:** A set of layers and protocols.
- The higher layer includes the **application** level,
- Below layer 1 (**physical layer**) is the physical transmission medium through which actual communication occurs,
- **Interface:** Defines which primitive operations and services the lower layer offers to the upper layer,
- **Protocol stack:** A list of protocols used by a certain system, one protocol per layer.

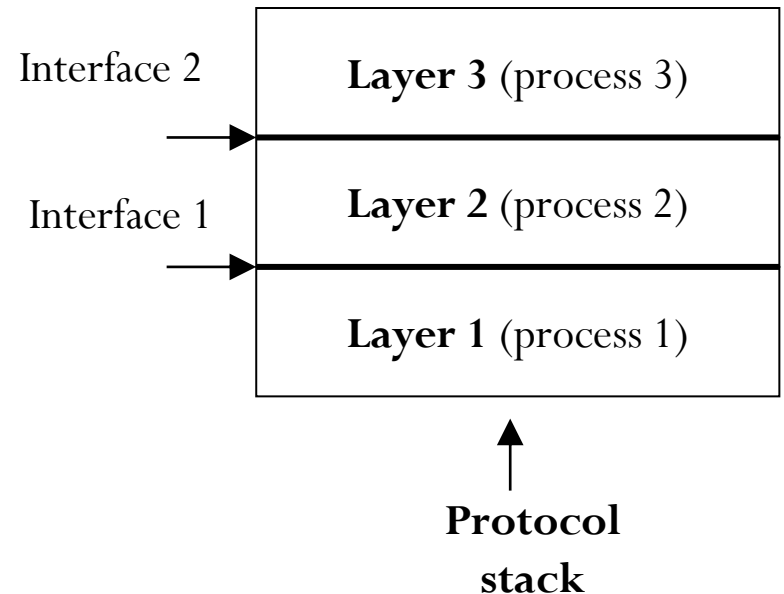

4.3. Protocols (3)

Why protocol and network architectures?

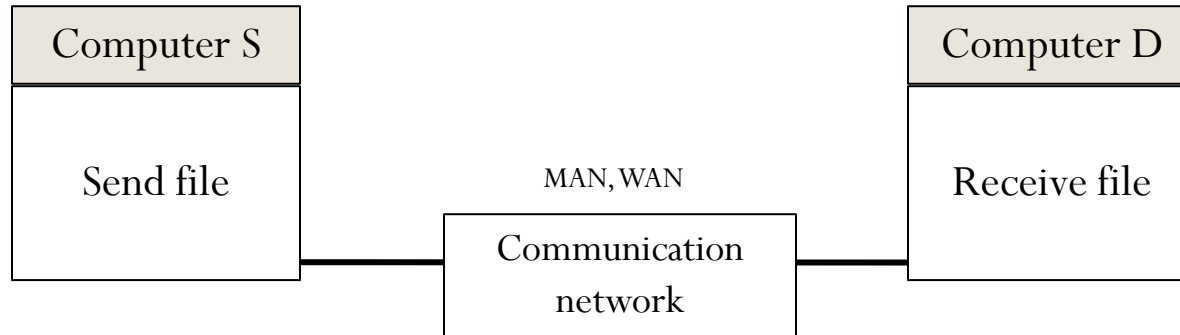

Source → Destination :

Information meets many processing types: transmission, media, reception, extraction...

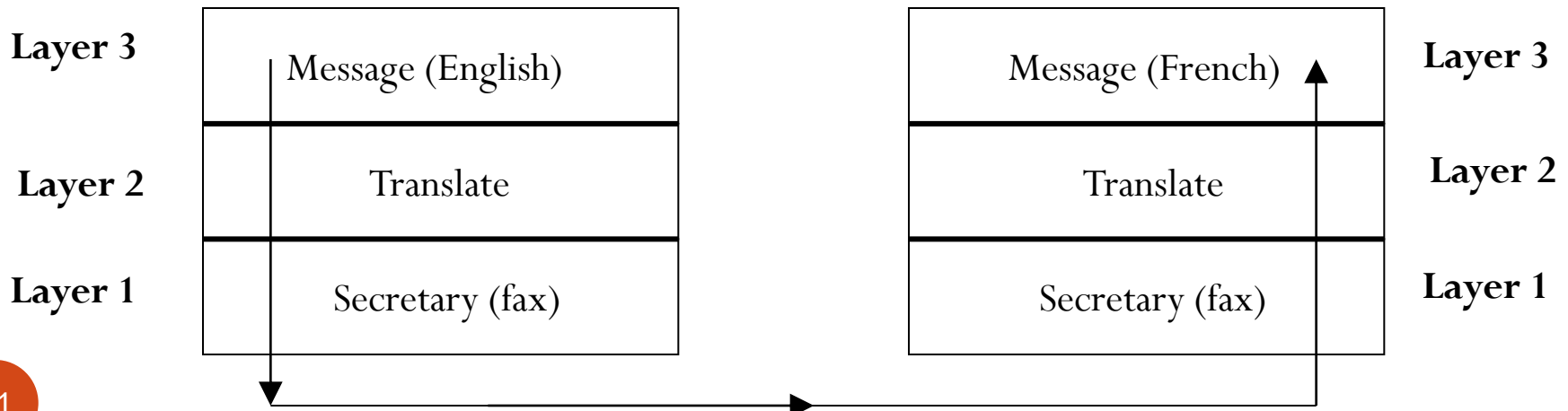

4.3. Protocols (4)

Service Primitives

A service is formally specified by primitives (operations) available to a user (or other entity) to access the service. These primitives tell the service to perform some action (or report) on an action taken by a peer entity.

Four classes of service primitives:

Primitive	Meaning
Request	An entity wants the service to do some work
Indication	An entity is to be informed about an event
Response	An entity wants to respond to an event
Confirm	The response to an earlier request has come back

4.3. Protocols (5)

Service Primitives

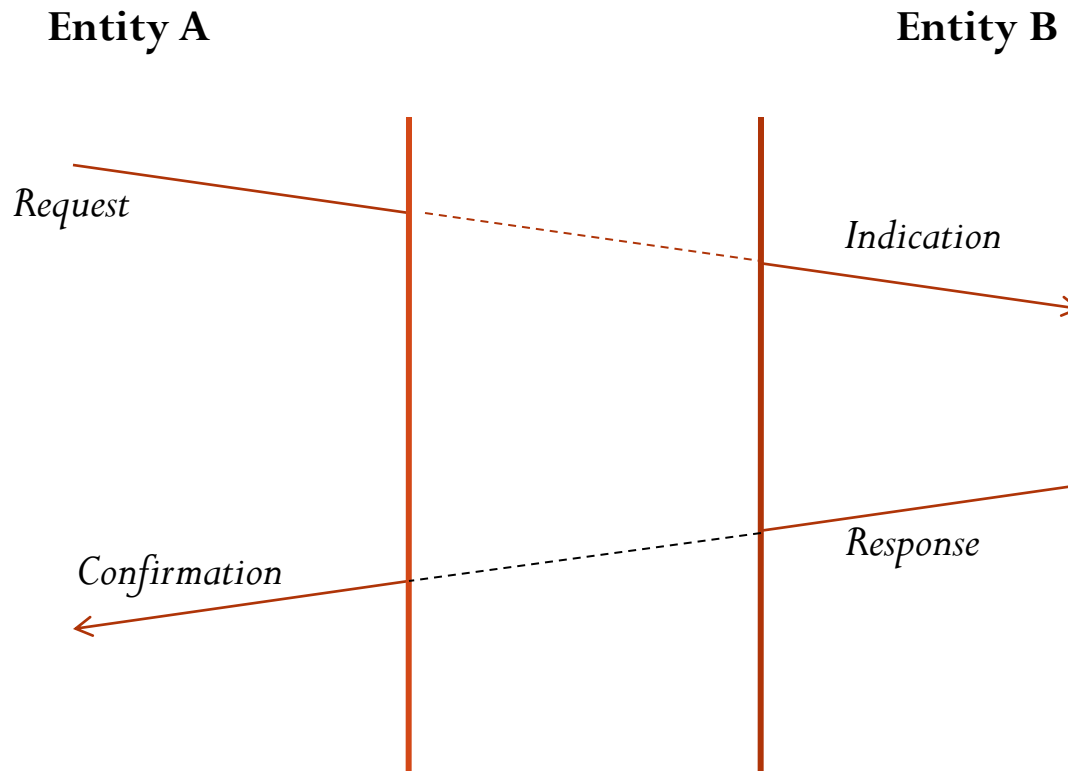

4.3. Protocols (6)

Service Primitives – Example. Connection Establishment

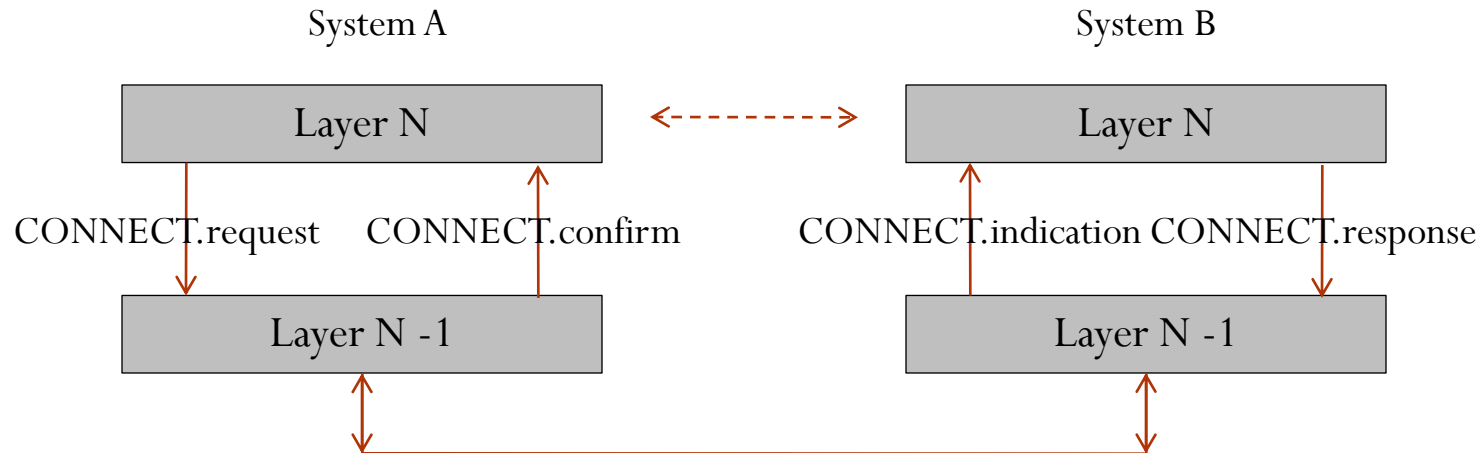

- Layer N of System A, requests layer N - 1 to establish a connection by requesting its service CONNET by issuing a CONNET.request primitive. This results in a message being send by the layer N - 1 entity in System A to layer N – 1 in System B.
- The CONNECT service in layer N - 1 of System B notifies layer N of the establishment request by issuing a CONNECT.indication.
- Layer N uses the CONNECT.response primitive to tell layer N - 1 whether it wants to accept or reject the proposed connection.
- The layer N - 1 entity in System B sends a message to the layer N -1 entity in System A with the response of the layer N entity in System B.
- The entity in layer N - 1 of System A informs the requesting Layer N entity in a CONNET.confirm primitive of the outcome of the connection establishment.

4.3. Protocols (7)

Service Primitives

Services can either be confirmed or unconfirmed.

- In a confirmed service there is a request, indication, response, and confirm.
Example. connection establishment.
- In an unconfirmed service, there is just a request and an indication.
Example. data exchange on an established connection , which typically uses the primitives DATA.request and DATA.indication.

5. What is Internet Technology?

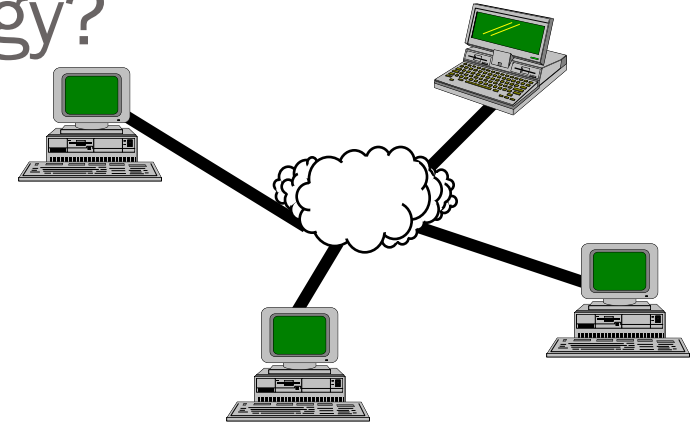

- What is an internet?
 - Network of networks
 - Intranet: A private version of the Internet (operates within the organization for internal purposes & can exist as isolated)
- What is *the* Internet?
 - A global internet based on the IP protocol. A collection of com. Networks interconnected by bridges and/or routers.
- To what does “Internet technology” refer?
 - Architecture, protocols and services

5.1. Internet devices

- **End systems.** A device attached to one of the Networks that is used to support end-user applications or services.
- **Intermediate system (IS).** A device used to connect two networks and permit com. between end systems attached to different networks.
- **Bridge.** An IS used to connect two LANs that use similar protocols.
- **Router.** An IS used to connect two networks that may and may not be similar.

5.2. Sample Internet Applications

- Electronic mail
- Remote terminal
- File transfer
- Newsgroups
- File sharing
- Resource distribution
- World Wide Web
- Video conferencing
- Games

5.3. Impact of the Net on People

- Access to remote information
 - HW assignments from my server
- Person to person and group communication
 - email, collaborative tools
- Interactive entertainment
 - Corporate video, news clips

5.4. Impact of the Net on Society

- The good
 - Access to information, e-commerce
- The bad
 - drudge report, gossip, too much information, jenny cam
- The ugly
 - Fraud ...
- But, it is just a mirror of society

5.5. Internet Actors

- Users, people who use the applications
 - Everyone (mom and pop, kids)
 - get something done (hopefully useful)
- Designers
 - You: protocol design and implementation
 - performance, cost and scale
- Service Providers
 - Administrators and ISPs (Internet Service Providers)
 - Management, revenue, deployment

5.6. Internet

- An internet is a *group of networks* linked together with *routers* in a way that allows an application program on any station on any network in the internet to be able to communicate with an application program on another station on any other network.

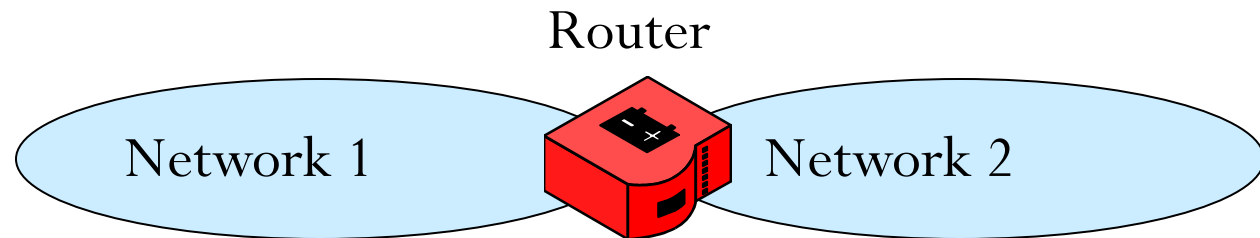

Reference

- Slides, Dr. Ridha Ouni
- A. S. Tanenbaum
 - “Computer Networks”, 4rd Ed., Prentice-Hall, '03.
- Panko’s *Business Data Networks and Telecommunications*, 4th edition
- J. Kurose and K. Ross
 - “Computer Networking: A Top-Down Approach Featuring the Internet” 1st Ed., Addison-Wesley, '00