

Introduction To Materials Science, Chapter 6, Mechanical Properties of Metals

Chapter Outline

Mechanical Properties of Metals

How do metals respond to external loads?

- **Stress and Strain**
 - Tension
 - Compression
 - Shear
 - Torsion
- **Elastic deformation**
- **Plastic Deformation**
 - Yield Strength
 - Tensile Strength
 - Ductility
 - Toughness
 - Hardness

Not tested: true stress-true strain relationships, resilience, details of the different types of hardness tests, variability of material properties



**Mechanical Engineering Department, King Saud University, P.O. Box 800,
Riyadh 11421, Saudi Arabia**



Introduction To Materials Science, Chapter 6, Mechanical Properties of Metals

Introduction

To understand and describe how materials deform (elongate, compress, twist) or break as a function of applied load, time, temperature, and other conditions we need first to discuss standard test methods and standard language for mechanical properties of materials.

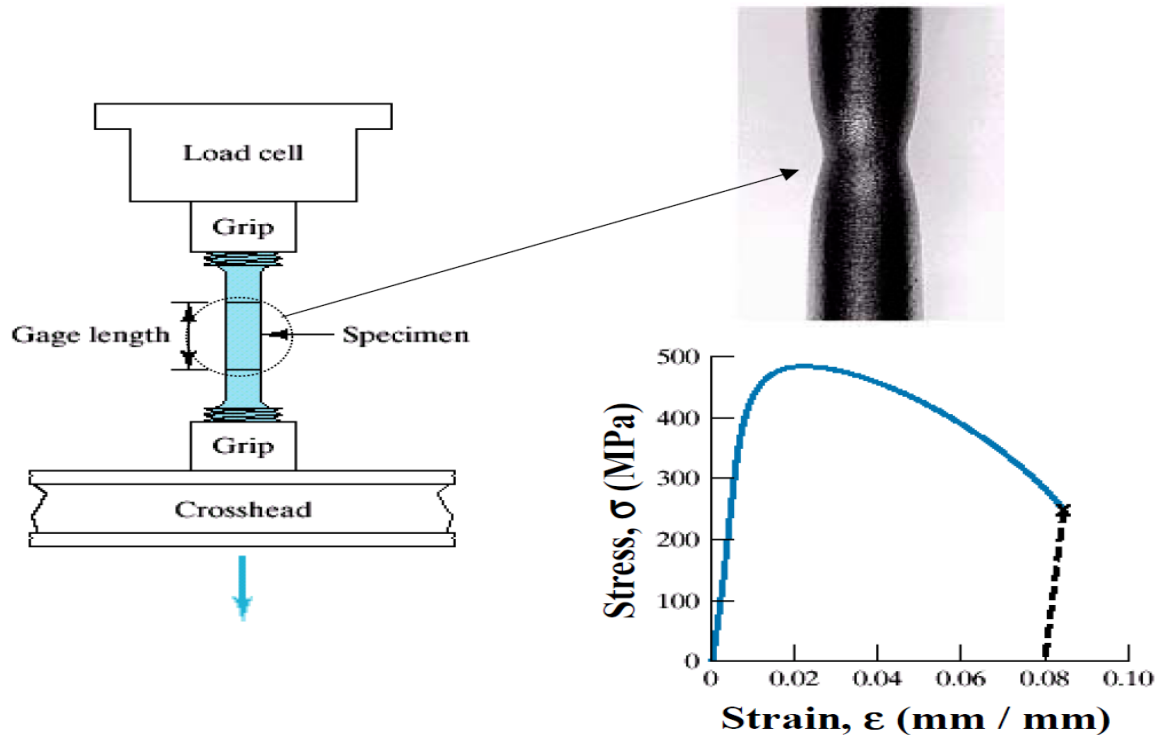

Mechanical Engineering Department, King Saud University, P.O. Box 800,
Riyadh 11421, Saudi Arabia



Introduction To Materials Science, Chapter 6, Mechanical Properties of Metals

Types of Loading

Tensile

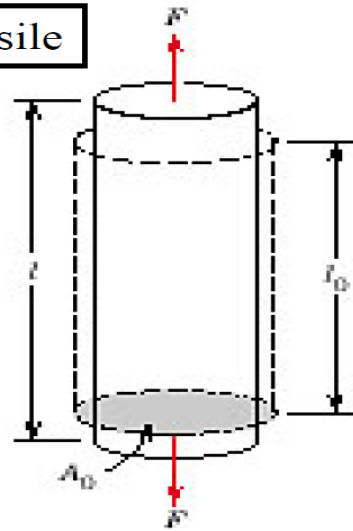

Compressive

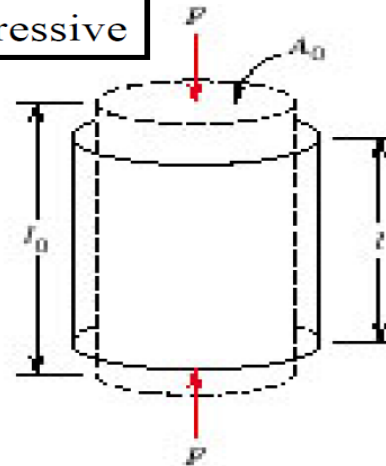

Shear

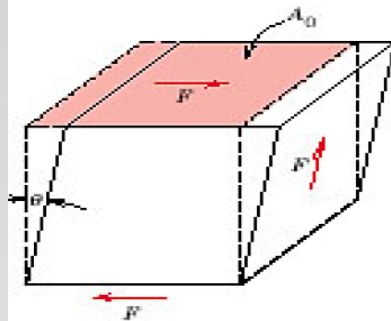

Torsion

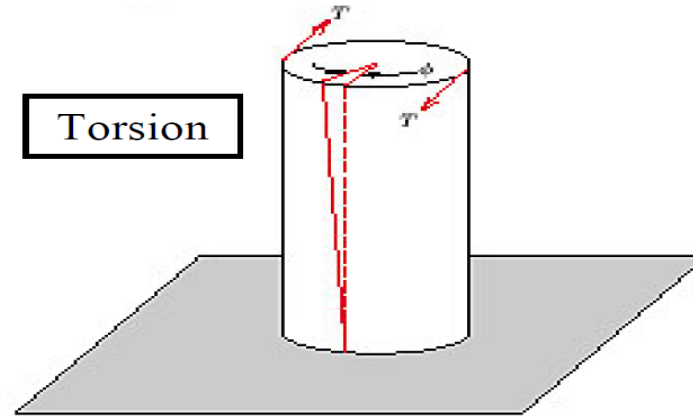

Introduction To Materials Science, Chapter 6, Mechanical Properties of Metals

Concepts of Stress and Strain (tension and compression)

To compare specimens of different sizes, the load is calculated per unit area.

Engineering stress: $\sigma = F / A_0$

F is load applied perpendicular to specimen cross-section; A_0 is cross-sectional area (perpendicular to the force) **before** application of the load.

Engineering strain: $\epsilon = \Delta l / l_0 \quad (\times 100 \%)$

Δl is change in length, l_0 is the original length.

These definitions of stress and strain allow one to compare test results for specimens of different cross-sectional area A_0 and of different length l_0 .

Stress and strain are positive for tensile loads, negative for compressive loads



Mechanical Engineering Department, King Saud University, P.O. Box 800,
Riyadh 11421, Saudi Arabia



Concepts of Stress and Strain (shear and torsion)

Shear stress: $\tau = F / A_0$

F is load applied parallel to the upper and lower faces each of which has an area A_0 .

Shear strain: $\gamma = \text{tg}\theta$ ($\times 100 \%$)

θ is strain angle

Torsion is variation of pure shear. A shear stress in this case is a function of applied torque T, shear strain is related to the angle of twist, ϕ .

Shear

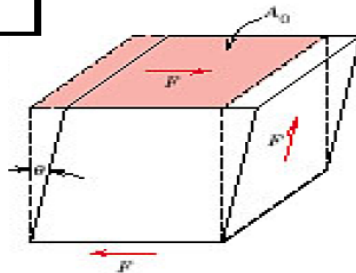

Torsion

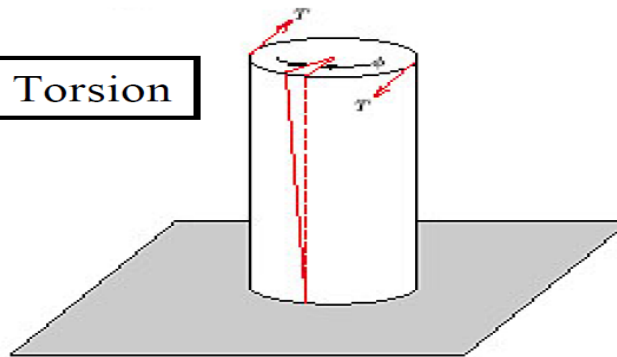

Stress-Strain Behavior

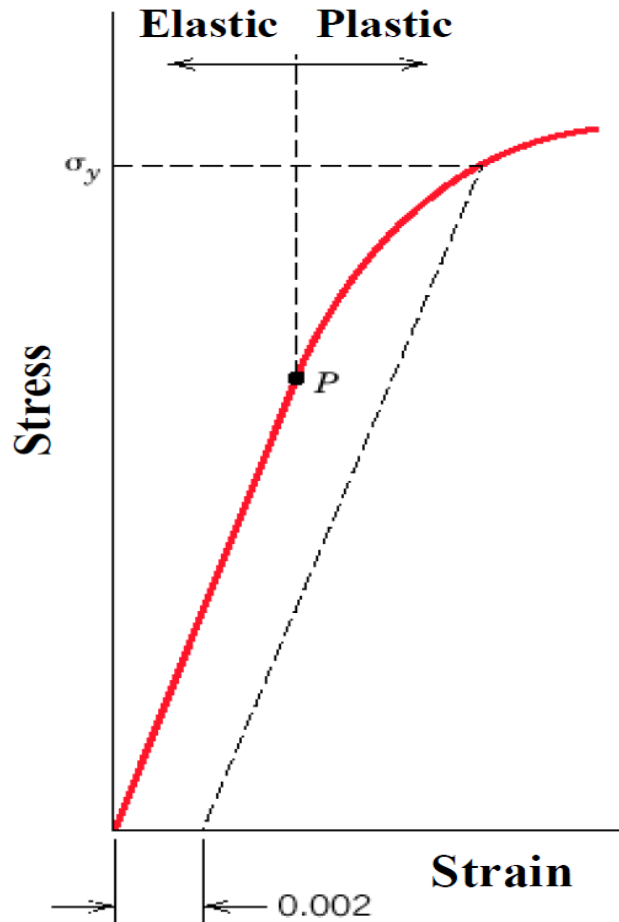

Elastic deformation

Reversible: when the stress is removed, the material returns to the dimension it had before the loading.

Usually strains are small (except for the case of plastics).

Plastic deformation

Irreversible: when the stress is removed, the material does not return to its previous dimension.

Introduction To Materials Science, Chapter 6, Mechanical Properties of Metals

Stress-Strain Behavior: Elastic deformation

In tensile tests, if the deformation is elastic, the stress-strain relationship is called **Hooke's law**:

$$\sigma = E \epsilon$$

E is **Young's modulus** or **modulus of elasticity**, has the same units as σ , N/m² or Pa

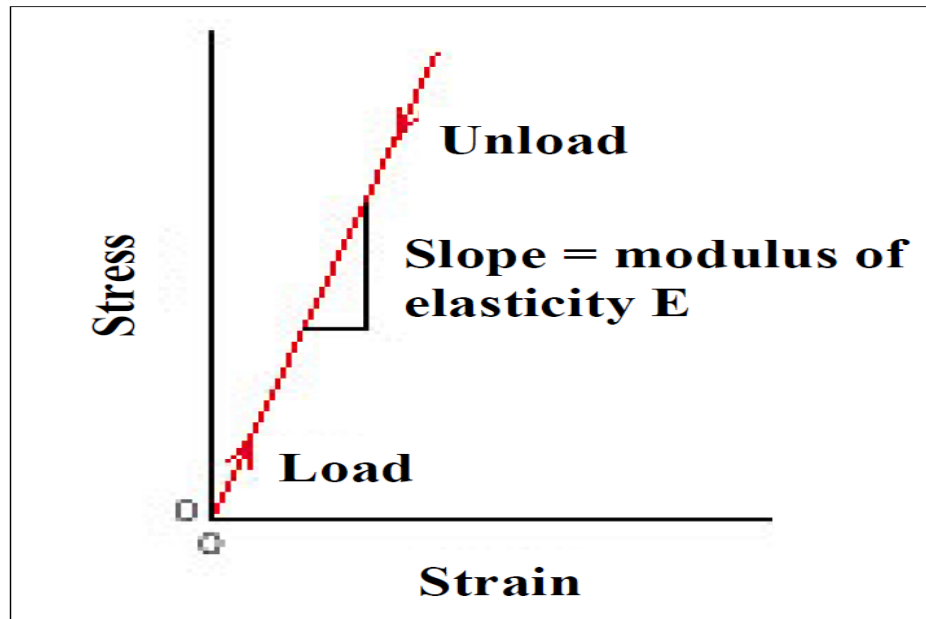

Higher E → higher “stiffness”

Elastic Deformation: Nonlinear elastic behavior

In some materials (many polymers, concrete...), elastic deformation is not linear, but it is still reversible.

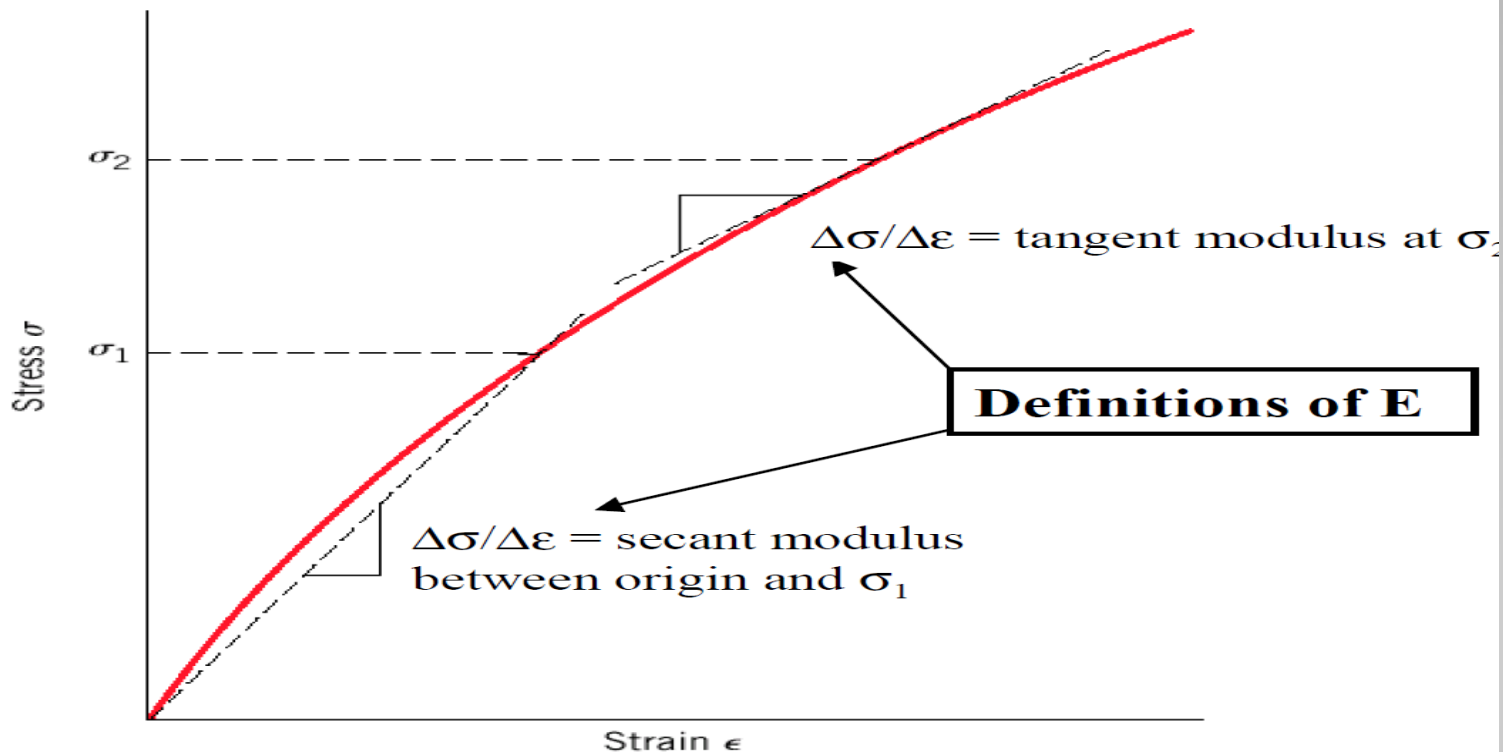

Elastic Deformation: Anelasticity (time dependence of elastic deformation)

- So far we have assumed that elastic deformation is time independent (i.e. applied stress produces instantaneous elastic strain)
- However, in reality elastic deformation takes time (finite rate of atomic/molecular deformation processes) - continues after initial loading, and after load release. This time dependent elastic behavior is known as **anelasticity**.
- The effect is normally small for metals but can be significant for polymers (“**visco-elastic behavior**”).



Elastic Deformation: Poisson's ratio

Unloaded

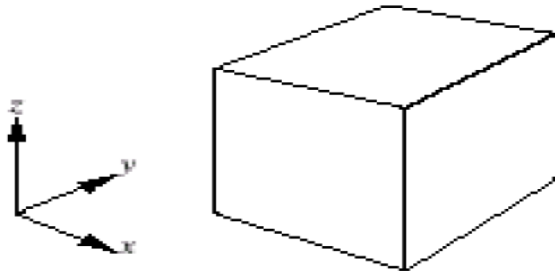

Loaded

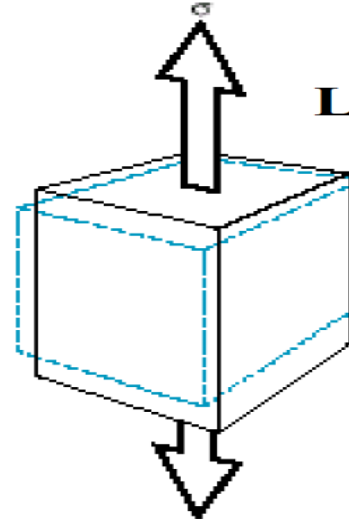

$$\nu = -\frac{\epsilon_x}{\epsilon_z} = -\frac{\epsilon_y}{\epsilon_z}$$

Materials subject to tension shrink laterally. Those subject to compression, bulge. The ratio of lateral and axial strains is called the Poisson's ratio ν .

ν is dimensionless, sign shows that lateral strain is in opposite sense to longitudinal strain

Theoretical value for isotropic material: 0.25

Maximum value: 0.50, Typical value: 0.24 - 0.30

Elastic Deformation: Shear Modulus

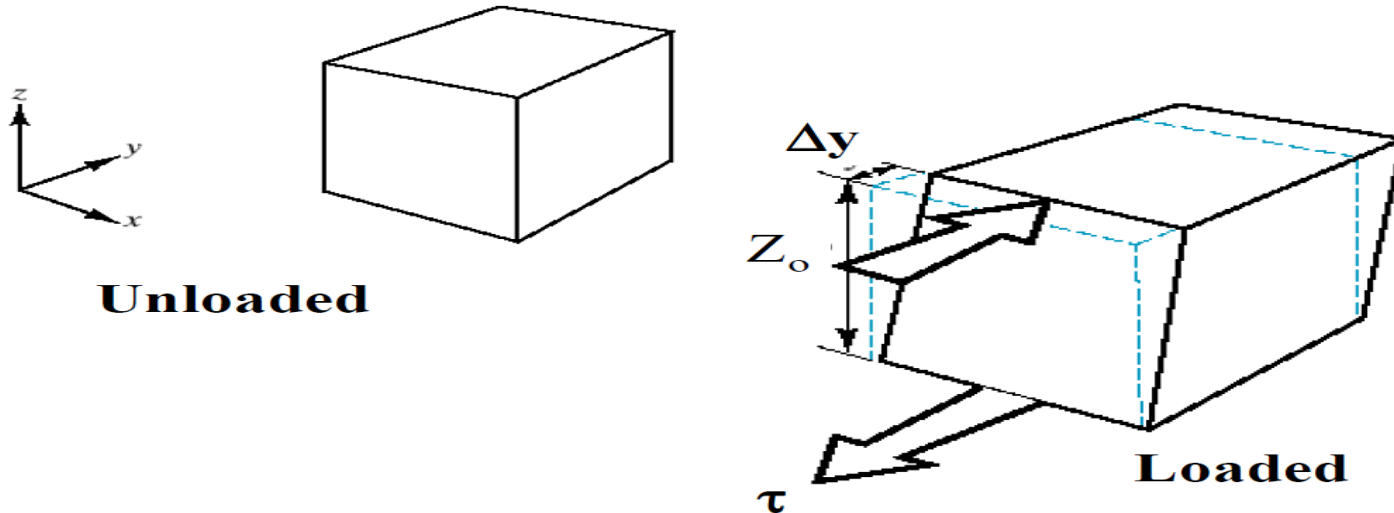

Relationship of shear stress to shear strain:

$\tau = G \gamma$, where: $\gamma = \text{tg}\theta = \Delta y / z_0$
G is Shear Modulus (Units: N/m²)

For isotropic material:

$E = 2G(1+\nu) \rightarrow G \sim 0.4E$

(Note: single crystals are usually elastically anisotropic: the elastic behavior varies with crystallographic direction, see Chapter 3)

Introduction To Materials Science, Chapter 6, Mechanical Properties of Metals

Stress-Strain Behavior: Plastic deformation

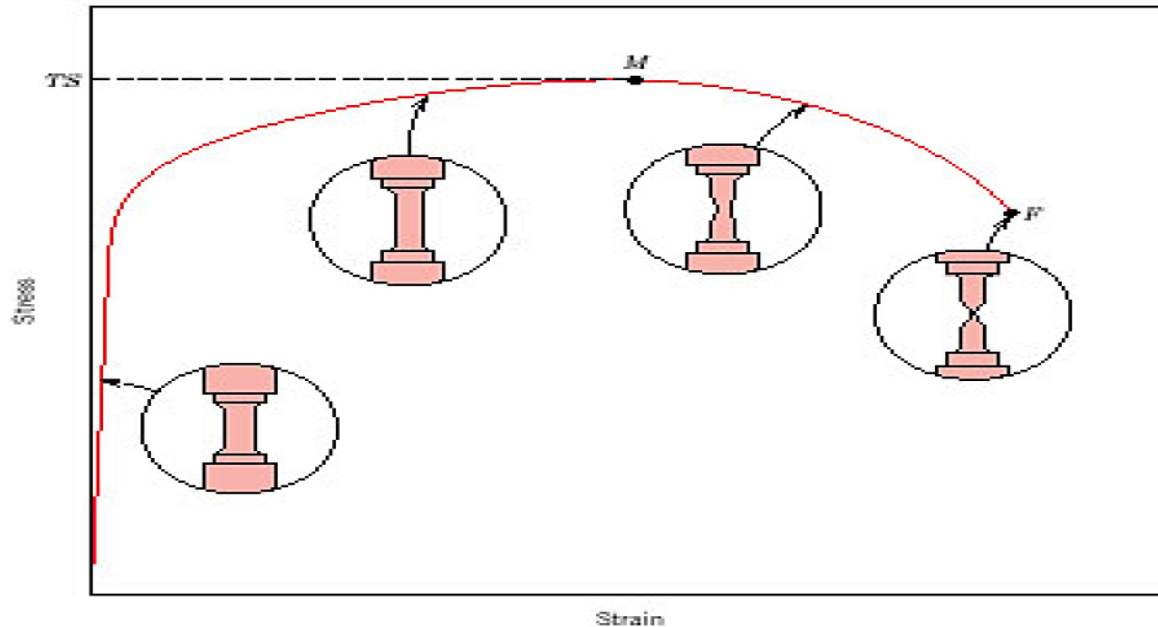

Plastic deformation:

- stress and strain are not proportional
- the deformation is not reversible
- deformation occurs by breaking and re-arrangement of atomic bonds (in crystalline materials primarily by motion of dislocations, Chapter 7)

Tensile properties: Yielding

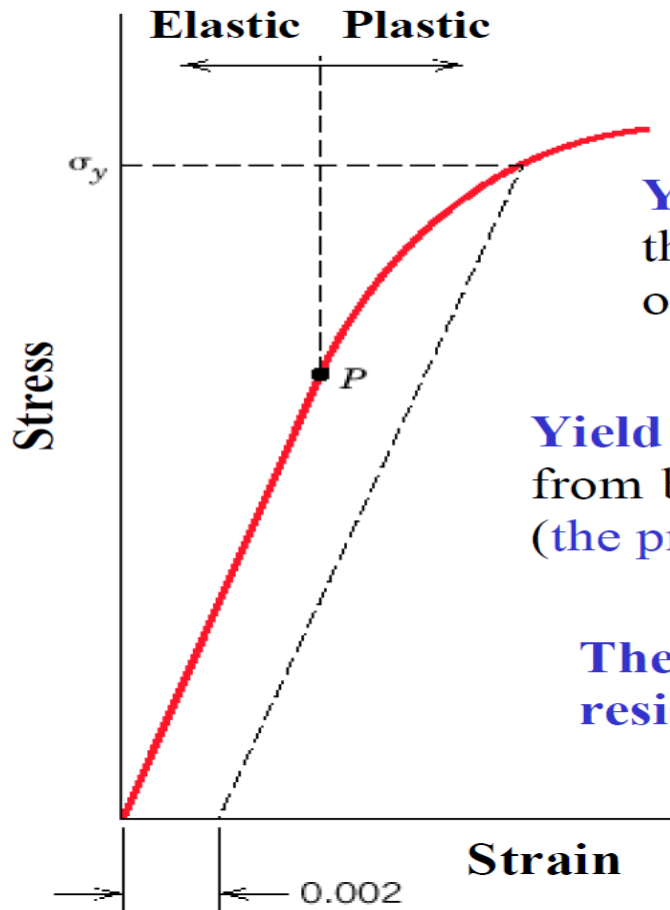

Yield strength σ_y - is chosen as that causing a permanent strain of 0.002

Yield point P - the strain deviates from being proportional to the stress (the proportional limit)

The yield stress is a measure of resistance to plastic deformation

Tensile properties: Yielding

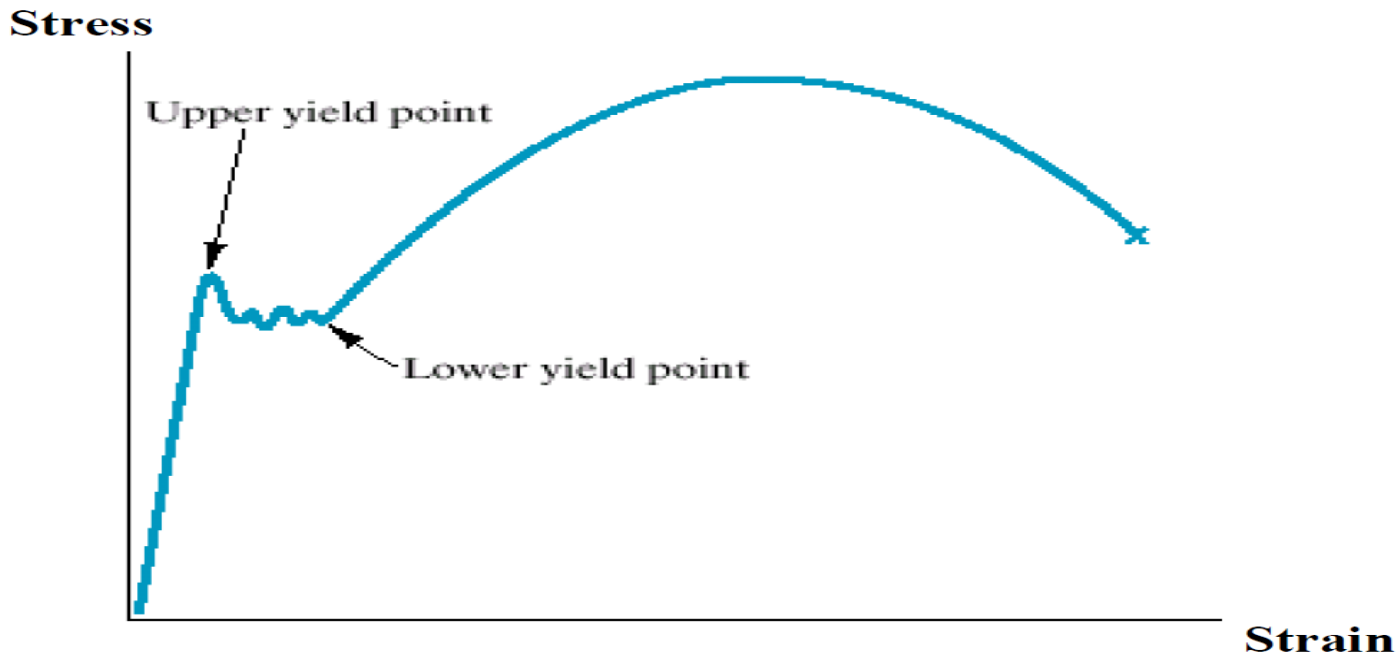

For a low-carbon steel, the stress vs. strain curve includes both an upper and lower yield point. The yield strength is defined in this case as the average stress at the lower yield point.

Tensile Strength

If stress = tensile strength is maintained then specimen will eventually break

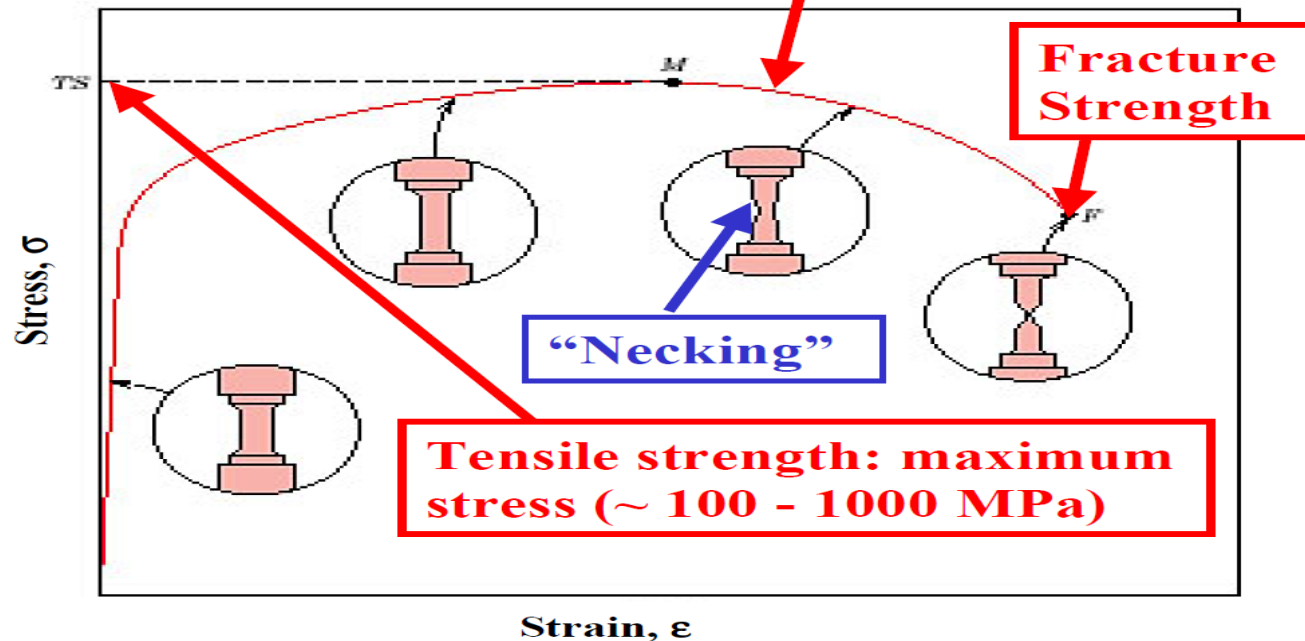

For structural applications, the yield stress is usually a more important property than the tensile strength, since once the yield stress has passed, the structure has deformed beyond acceptable limits.

Tensile properties: Ductility

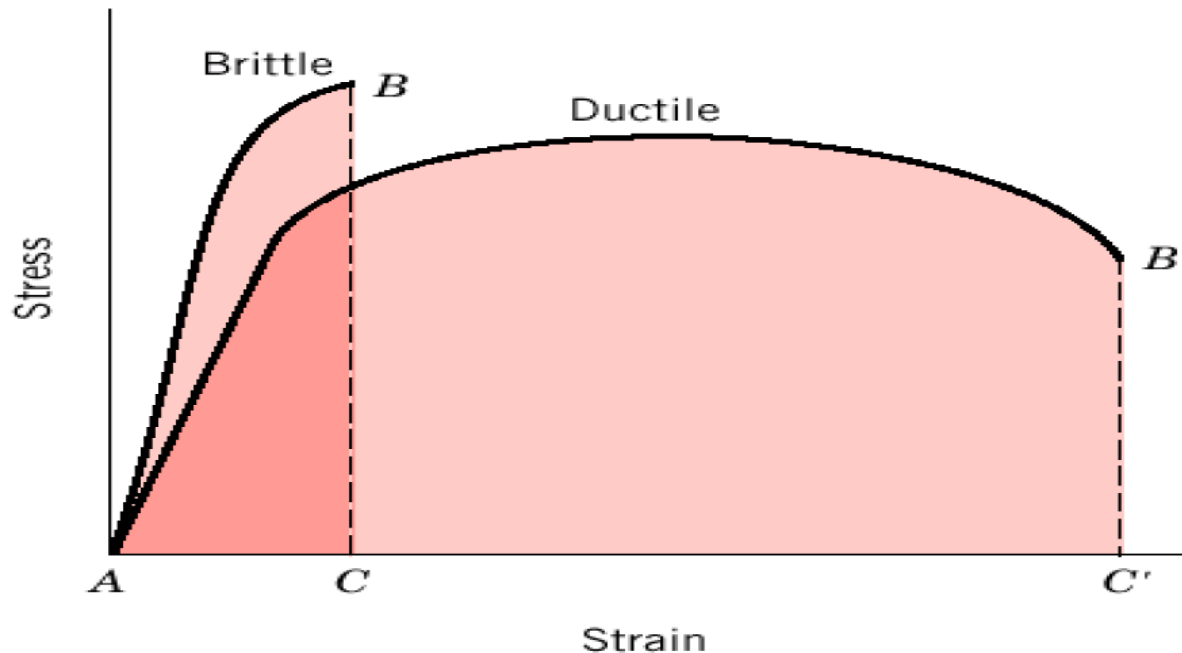

Ductility is a measure of the deformation at fracture

Defined by
percent elongation
or

percent reduction in area

$$\%EL = \left(\frac{l_f - l_0}{l_0} \right) \times 100$$

$$\%RA = \left(\frac{A_0 - A_f}{A_0} \right) \times 100$$



Introduction To Materials Science, Chapter 6, Mechanical Properties of Metals

Typical mechanical properties of metals

<i>Metal Alloy</i>	<i>Yield Strength MPa (ksi)</i>	<i>Tensile Strength MPa (ksi)</i>	<i>Ductility, %EL [in 50 mm (2 in.)]</i>
Aluminum	35 (5)	90 (13)	40
Copper	69 (10)	200 (29)	45
Brass (70Cu–30Zn)	75 (11)	300 (44)	68
Iron	130 (19)	262 (38)	45
Nickel	138 (20)	480 (70)	40
Steel (1020)	180 (26)	380 (55)	25
Titanium	450 (65)	520 (75)	25
Molybdenum	565 (82)	655 (95)	35

The yield strength and tensile strength vary with prior thermal and mechanical treatment, impurity levels, etc. This variability is related to the behavior of dislocations in the material, Chapter 7. But elastic moduli are relatively insensitive to these effects.

The yield and tensile strengths and modulus of elasticity decrease with increasing temperature, ductility increases with temperature.



**Mechanical Engineering Department, King Saud University, P.O. Box 800,
Riyadh 11421, Saudi Arabia**



Toughness

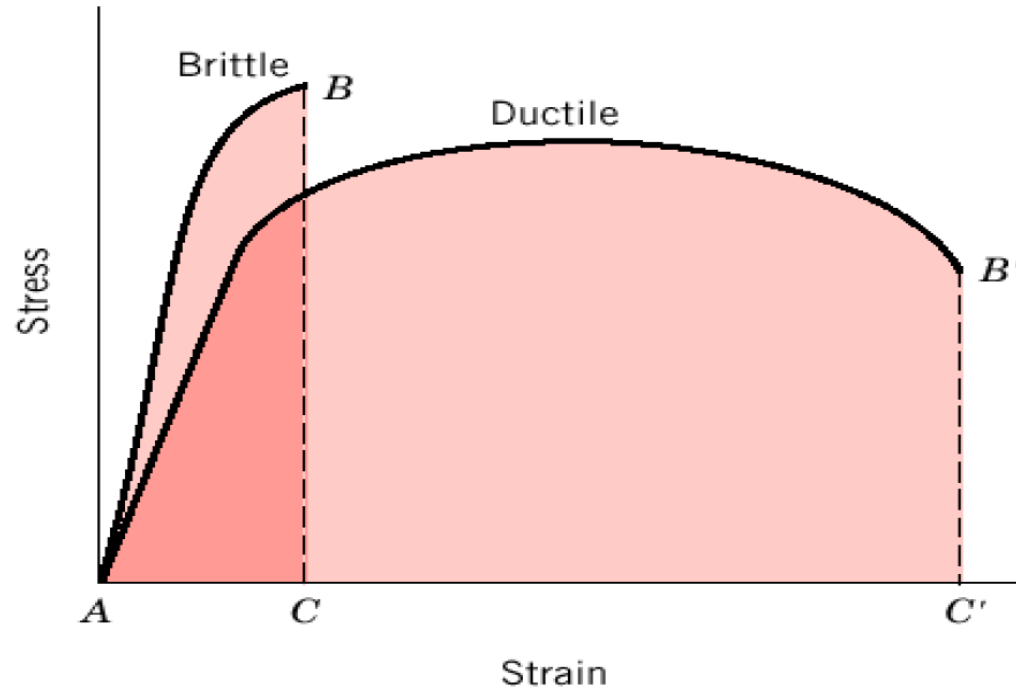

Toughness = the ability to absorb energy up to fracture = the total area under the strain-stress curve up to fracture

Units: the energy per unit volume, e.g. J/m^3

Can be measured by an impact test (Chapter 8).

Introduction To Materials Science, Chapter 6, Mechanical Properties of Metals

True Stress and Strain

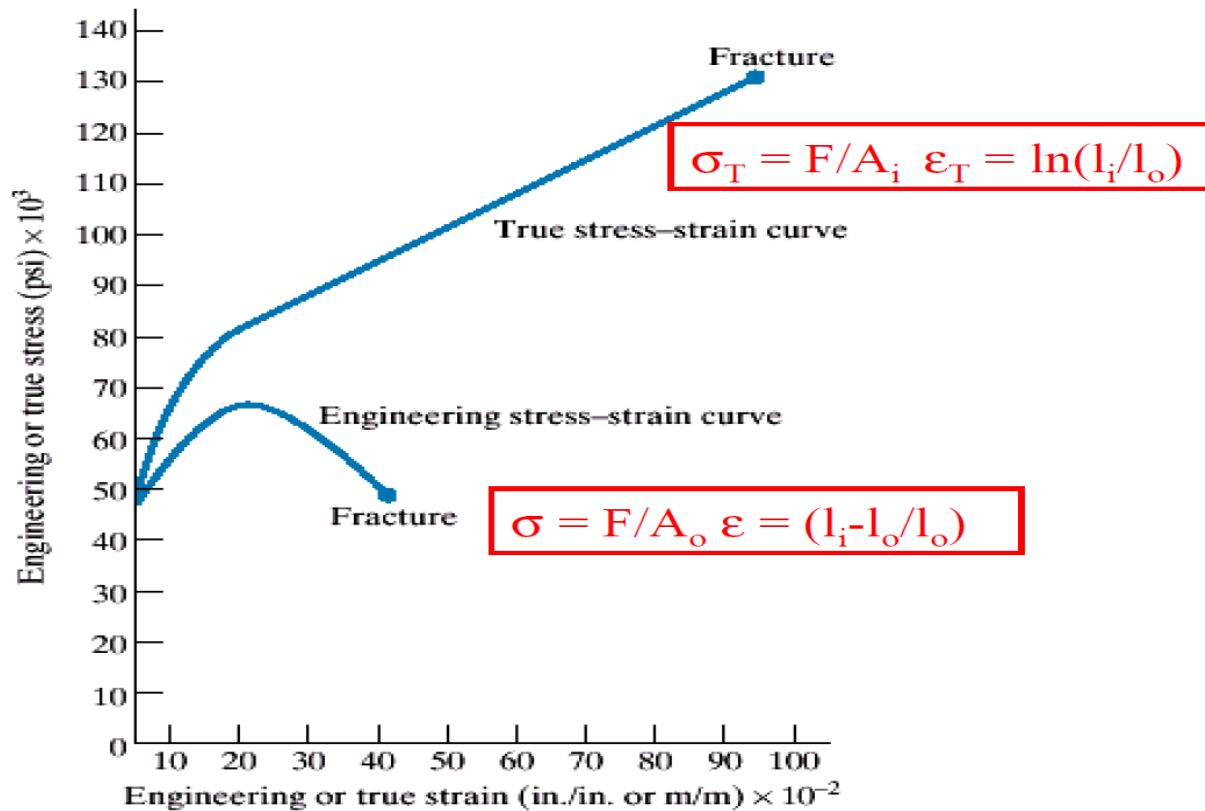

True stress = load divided by **actual area** in the necked-down region, continues to rise to the point of fracture, in contrast to the engineering stress.



Mechanical Engineering Department, King Saud University, P.O. Box 800,
Riyadh 11421, Saudi Arabia



Introduction To Materials Science, Chapter 6, Mechanical Properties of Metals

Elastic Recovery During Plastic Deformation

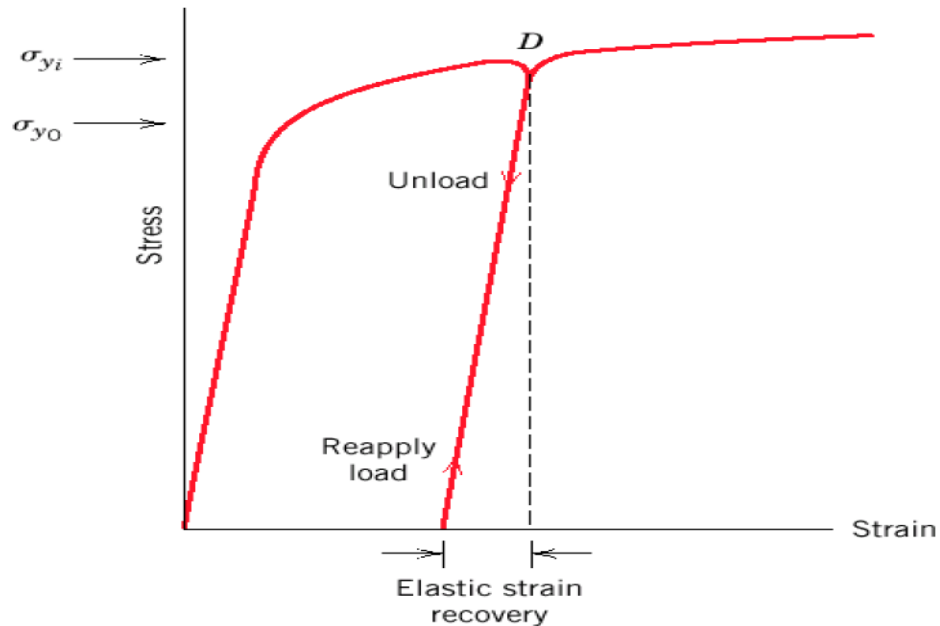

If a material is deformed plastically and the stress is then released, the material ends up with a permanent strain.

If the stress is reapplied, the material again responds elastically at the beginning up to a new yield point that is higher than the original yield point.

The amount of elastic strain that it will take before reaching the yield point is called **elastic strain recovery**.



Mechanical Engineering Department, King Saud University, P.O. Box 800,
Riyadh 11421, Saudi Arabia



Introduction To Materials Science, Chapter 6, Mechanical Properties of Metals

Hardness (I)

Hardness is a measure of the material's resistance to localized plastic deformation (e.g. dent or scratch)

A qualitative Moh's scale, determined by the ability of a material to scratch another material: from 1 (softest = talc) to 10 (hardest = diamond).

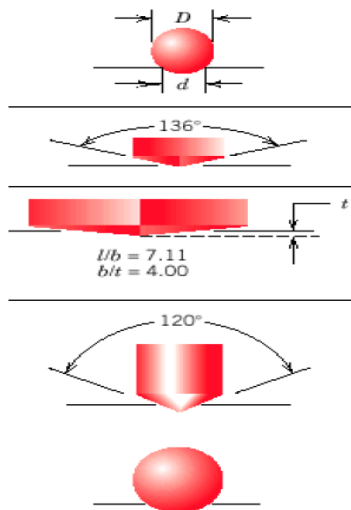

Different types of quantitative hardness test has been designed (Rockwell, Brinell, Vickers, etc.). Usually a small indenter (sphere, cone, or pyramid) is forced into the surface of a material under conditions of controlled magnitude and rate of loading. The depth or size of indentation is measured.

The tests somewhat approximate, but popular because they are easy and non-destructive (except for the small dent).

Introduction To Materials Science, Chapter 6, Mechanical Properties of Metals

Hardness (II)

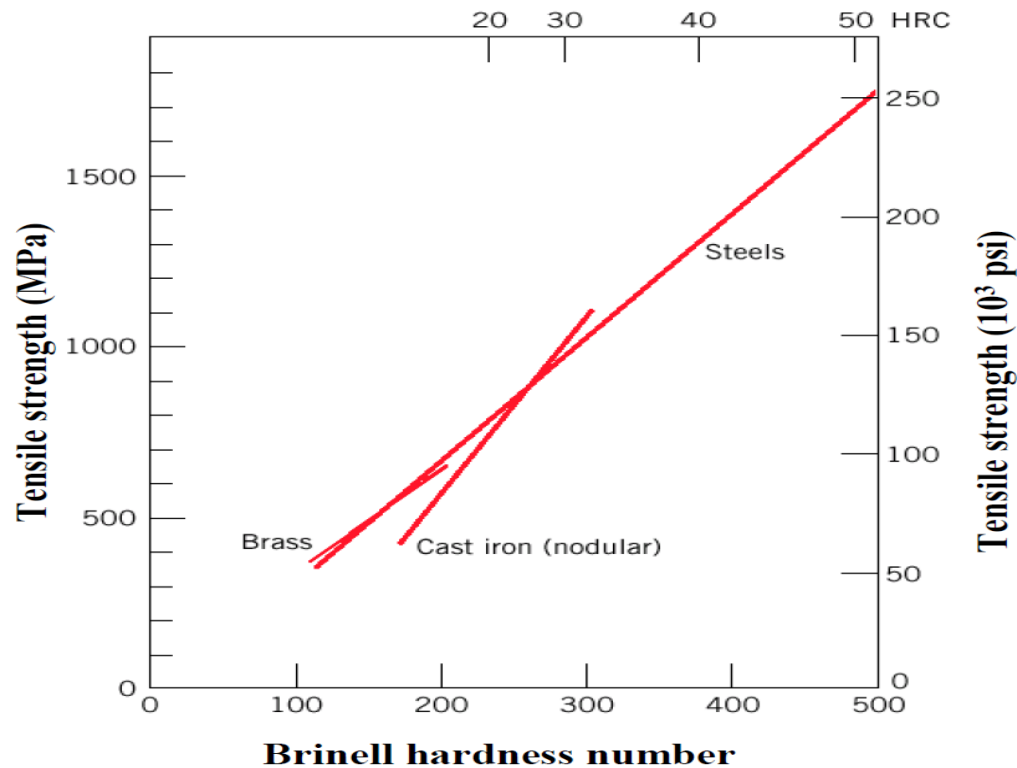

Both tensile strength and hardness may be regarded as degree of resistance to plastic deformation.

Hardness is proportional to the tensile strength - but note that the proportionality constant is different for different materials.



Mechanical Engineering Department, King Saud University, P.O. Box 800,
Riyadh 11421, Saudi Arabia



Introduction To Materials Science, Chapter 6, Mechanical Properties of Metals

Summary

Make sure you understand language and concepts:

- Anelasticity
- Ductility
- Elastic deformation
- Elastic recovery
- Engineering strain
- Engineering stress
- Hardness
- Modulus of elasticity
- Plastic deformation
- Poisson's ratio
- Proportional limit
- Shear
- Tensile strength
- Toughness
- Yielding
- Yield strength



**Mechanical Engineering Department, King Saud University, P.O. Box 800,
Riyadh 11421, Saudi Arabia**



Introduction To Materials Science, Chapter 6, Mechanical Properties of Metals

Reading for next class:

Chapter 7: Dislocations and Strengthening Mechanisms

➤ Dislocations and Plastic Deformation

- ✓ Motion of dislocations in response to stress
- ✓ Slip Systems
- ✓ Plastic deformation in
 - single crystals
 - polycrystalline materials

➤ Strengthening mechanisms

- ✓ Grain Size Reduction
- ✓ Solid Solution Strengthening
- ✓ Strain Hardening

➤ Recovery, Recrystallization, and Grain Growth

Optional reading (Part that is not covered / not tested):

7.7 Deformation by twinning

In our discussion of slip systems, §7.4, we will not get into direction and plane nomenclature



**Mechanical Engineering Department, King Saud University, P.O. Box 800,
Riyadh 11421, Saudi Arabia**

