



**Manufacturing Processes (2), IE-352**

**Ahmed M El-Sherbeeney, PhD**

**Fall 2021**

**Manufacturing Engineering Technology in SI Units, 6<sup>th</sup> Edition**

**Chapter 24: Machining Processes: Milling  
(Milling, Broaching, Sawing, Filing and Gear  
Manufacturing)**

# Chapter Outline

2

1. Introduction
2. Milling and Milling Machines
3. *Planing and Shaping*
4. *Broaching and Broaching Machines*
5. *Sawing*
6. *Gear Manufacturing by Machining*

# Introduction



3

- Last chapter: processes that produce round shapes
- Milling:
  - One of most common, versatile, economical machining processes
  - Rotating cutter removes material, traveling along various axes w.r.t. workpiece:
    - [Milling cutter](#) – multitooth tool: produces num. of chips / 1 rev
    - Takes place in a variety of configurations
    - Produces parts w/ complex external and internal features
- Similar processes ([not discussed here](#)):
  - Planing, shaping, broaching, sawing, filing, gear manufacturing
  - Either tool or workpiece travel along straight path
  - Produce flat or various shaped surfaces

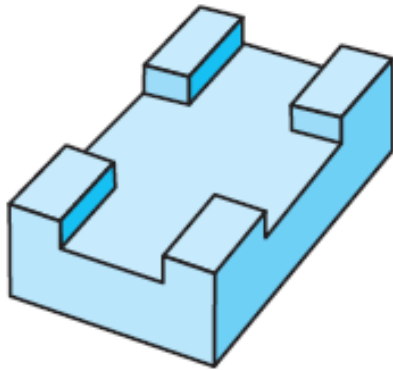

(a)

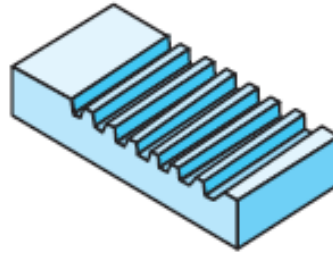

(b)

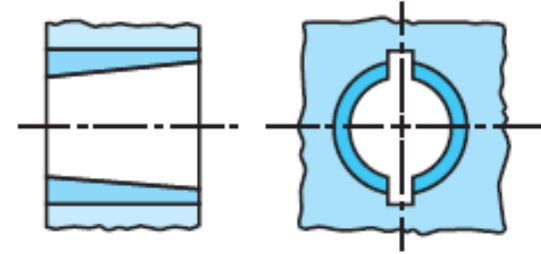

(c)

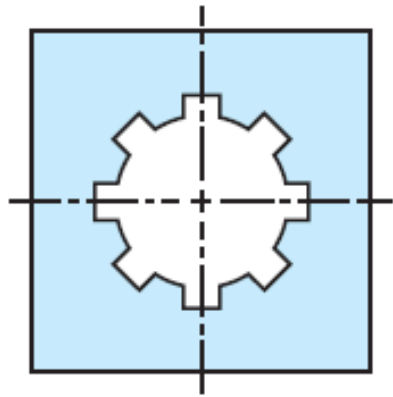

(d)

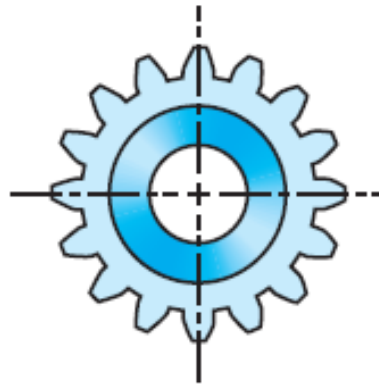

(e)

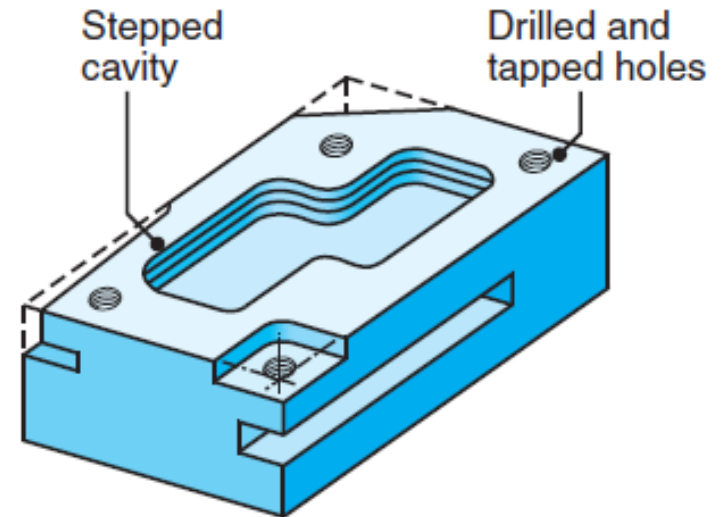

(f)

Typical parts and shapes that can be produced with machining processes described in this chapter. Can you guess how a) – f) are produced?

# Milling and Milling Machines



5

Some basic types of milling cutters and milling operations.

a) Peripheral (aka plain milling)

b) Face milling

c) End milling

d) Ball-end mill (with indexable coated-carbide inserts)

e) End mill using [5-axis](#) NC machine

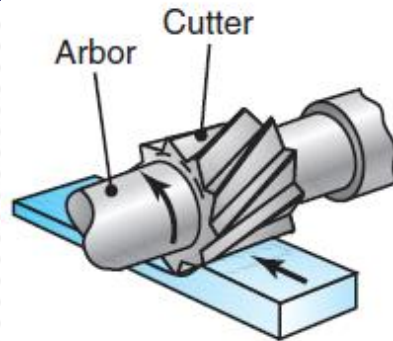

(a) Peripheral milling

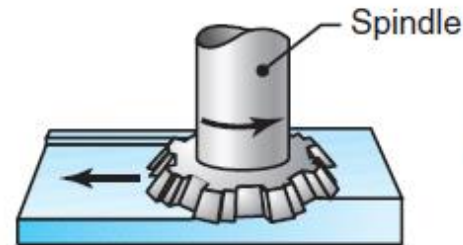

(b) Face milling

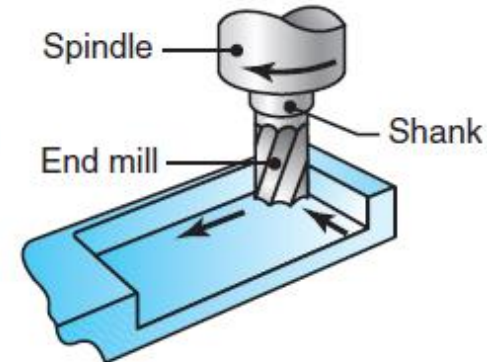

(c) End milling

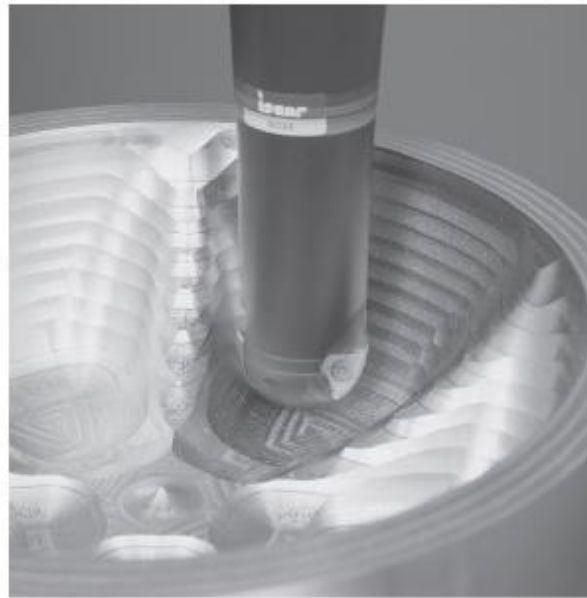

(d)



(e)

# Milling and Milling Machines:

## Peripheral Milling

6

- Axis of cutter rotation: parallel to workpiece surface
- Cutter body:
  - Generally made of high-speed steel
  - Has # of teeth along its circumference
  - Each tooth acts like a single-cutting tool
- When cutter: longer than width of cut
  - $\Rightarrow$  process is called *slab milling*
- Other types of peripheral milling are shown on the [next slide](#)

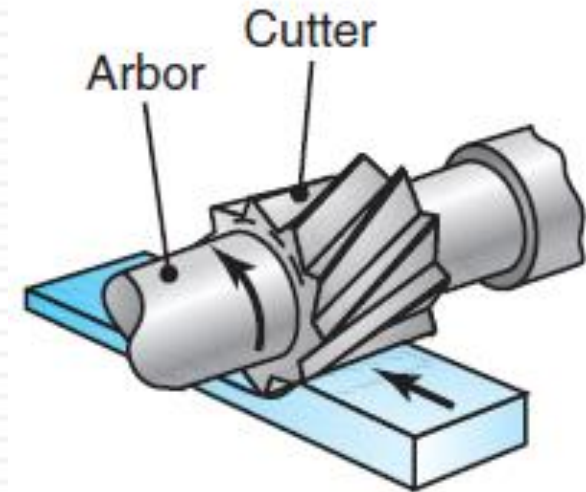
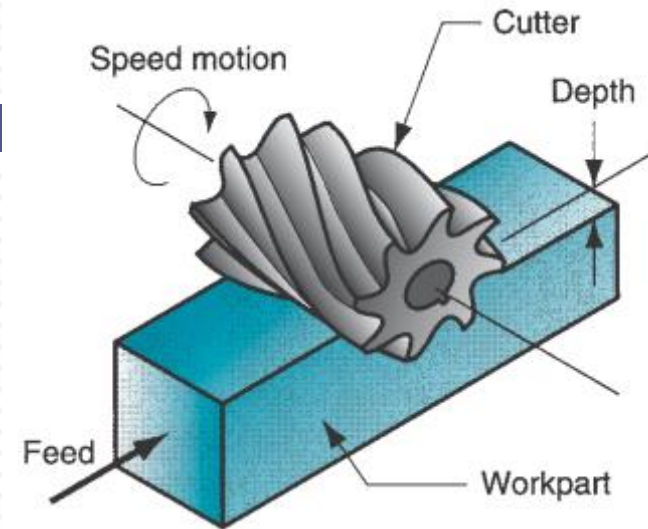

# Milling and Milling Machines:

## Peripheral Milling

7

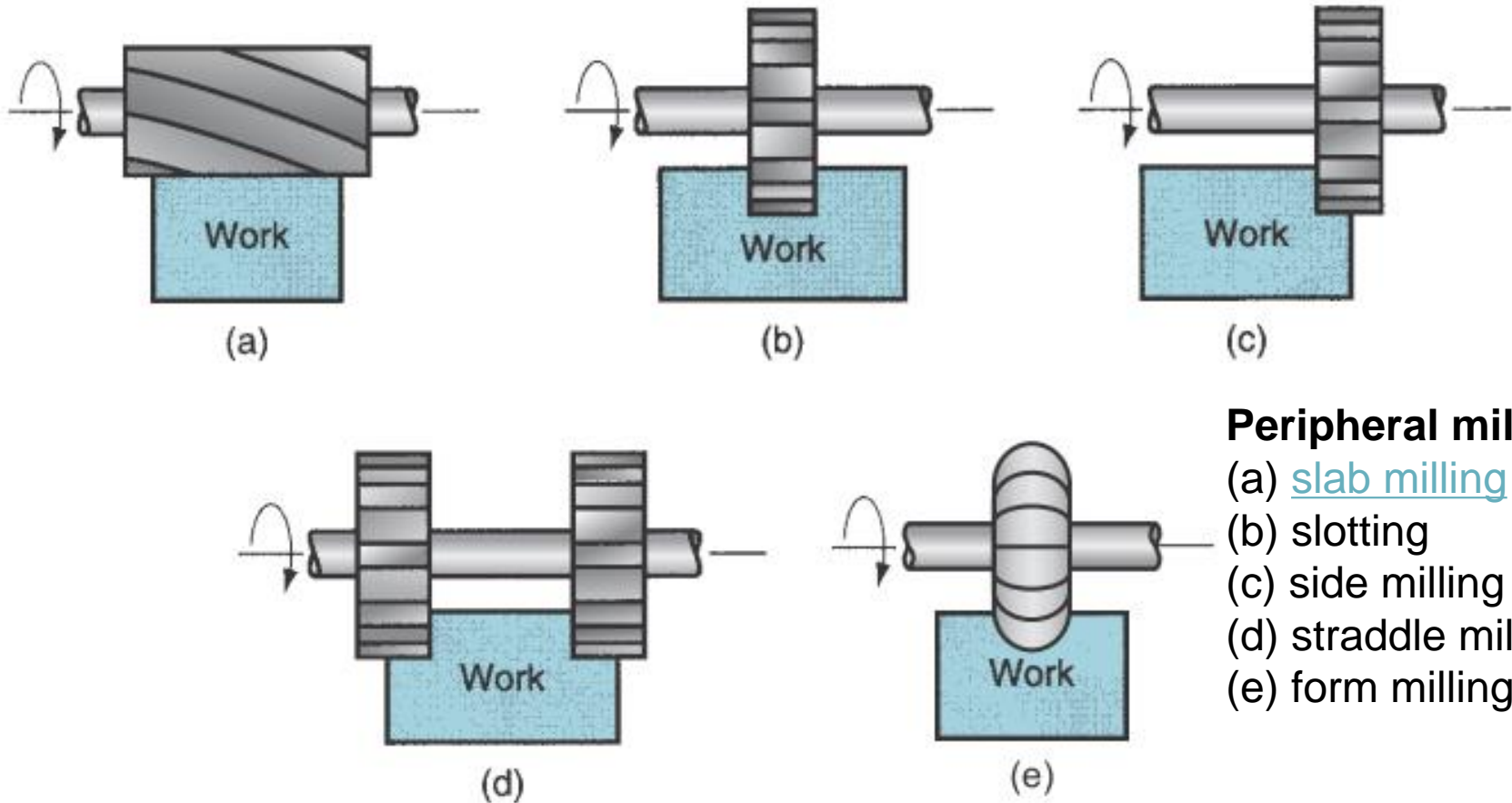

**Peripheral milling:**

- (a) [slab milling](#)
- (b) slotting
- (c) side milling
- (d) straddle milling
- (e) form milling

# Milling and Milling Machines:

## Peripheral Milling

8

- Orthogonal vs. oblique cutting (milling)
  - ▣ Cutters have straight or helical teeth
  - ▣  $\Rightarrow$  result in orthogonal or oblique cutting
  - ▣ Helical teeth preferred since:
    - teeth partially engaged with workpiece
    - $\Rightarrow$  lower  $F_c$  and torque on cutter
    - $\Rightarrow$  smoother operation, reduced chatter

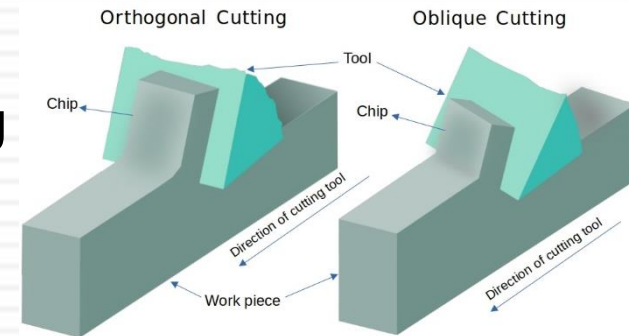

## Conventional Milling and Climb Milling

- Cutter rotation:
  - ▣ Conventional (aka up) milling,
  - ▣ Climb (aka down) milling
  - ▣ This is significant in operation

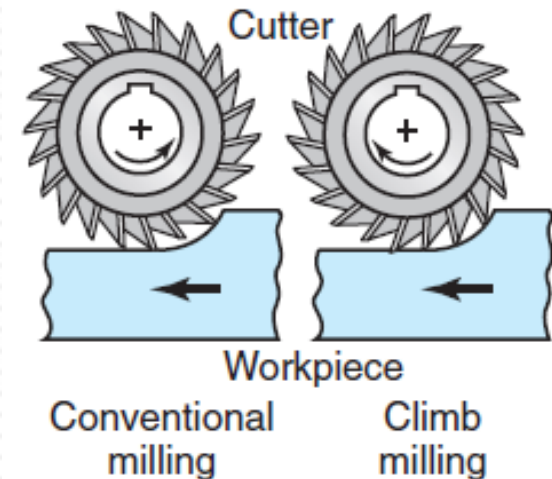

# Milling and Milling Machines:

## Peripheral Milling

9

### Cont. Conventional / Climb Milling

- Conventional (more common) milling
  - max.  $t_c$  is at end of cut
  - i.e. as tooth leaves workpiece ( $\rightarrow$ )
- Advantages:
  - Tooth engagement: not function of workpiece surface characteristics
  - Contamination/scale (oxide layer) on surface doesn't adversely affect  $T$
- Disadvantages:
  - If cutter teeth not sharp  $\Rightarrow$  tooth rubs on surface before cutting
  - Also: tool may chatter; workpiece may be pulled upward

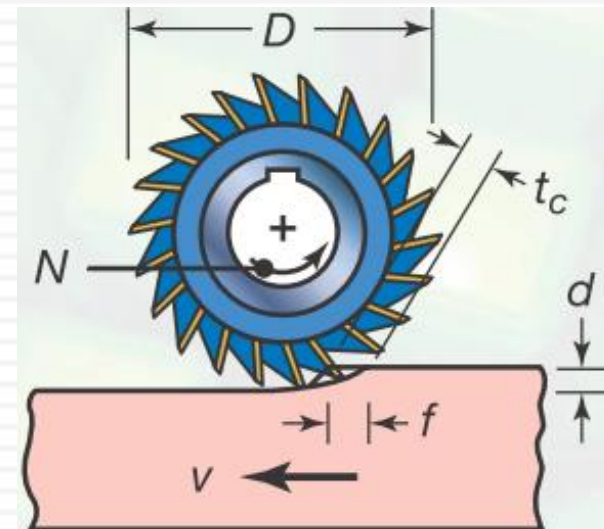
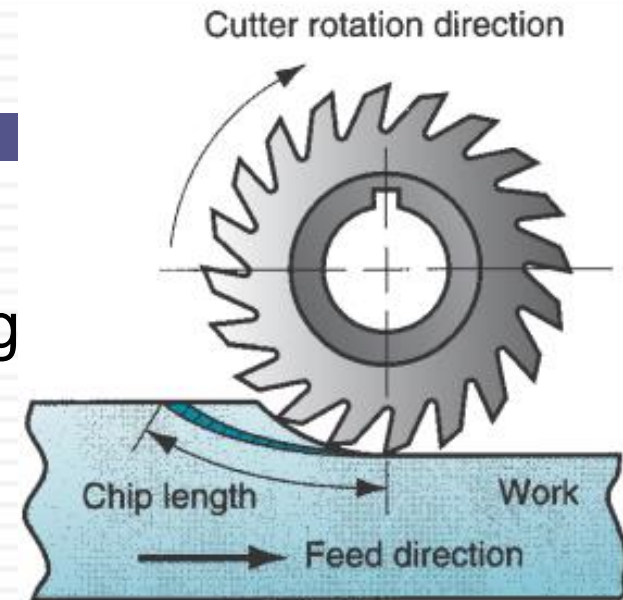

# Milling and Milling Machines:

## Peripheral Milling

10

Slab milling operation showing:

$d$ : depth of cut

$f$ : feed per tooth

$w$ : [width of cut](#) (not shown)

$t_c$ : chip depth of cut

$v$ : workpiece speed (feed rate)

$D$ : cutter diameter

$N$ : cutter rotational speed

$n$ : number of teeth on cutter periphery

Schematic illustration of:

$l_c$ : cutter travel distance (horizontal) to reach full depth of cut

$l$ : length of workpiece

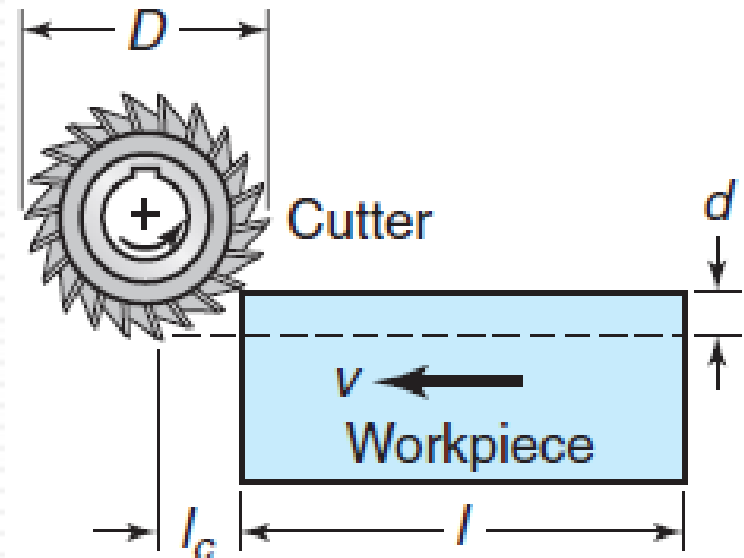
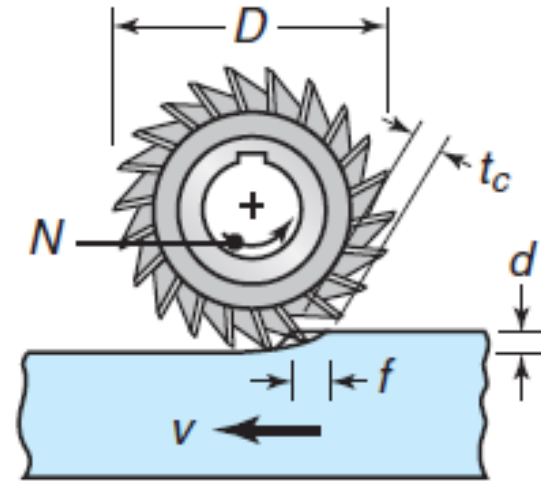

# Milling and Milling Machines:

## Peripheral Milling

11

### Cont. Conventional / Climb Milling

- Climb milling:
  - Cutting starts at surface of workpiece where chip is thickest →
- Advantage:
  - Downward component of  $F_c$  holds workpiece in place (esp. thin parts)
- Disadvantages:
  - Requires rigid work-holding setup
  - Gear backlash must be eliminated
  - Not suitable for workpieces with scale (e.g. hot-worked metals)
  - Note, scale  $\Rightarrow$  more wear  $\Rightarrow$  lower  $T$

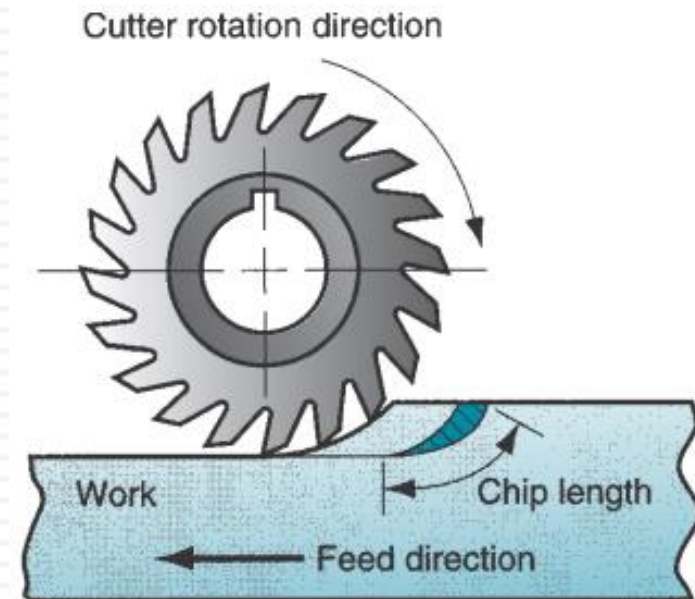

# Milling and Milling Machines:

## Peripheral Milling

12

### Milling Parameters

- Cutting speed in peripheral milling is surface speed of cutter:

$$V = \pi DN$$

- $t_c$  in slab milling:

- ▣ Varies along its length (due to relative longitudinal motion between cutter and workpiece)
- ▣ As  $t_c \uparrow \Rightarrow F_c \uparrow$
- ▣ For straight-tooth cutter, approx. undeformed  $t_c$  (chip depth of cut):

$$t_c = 2f \sqrt{\frac{d}{D}}$$

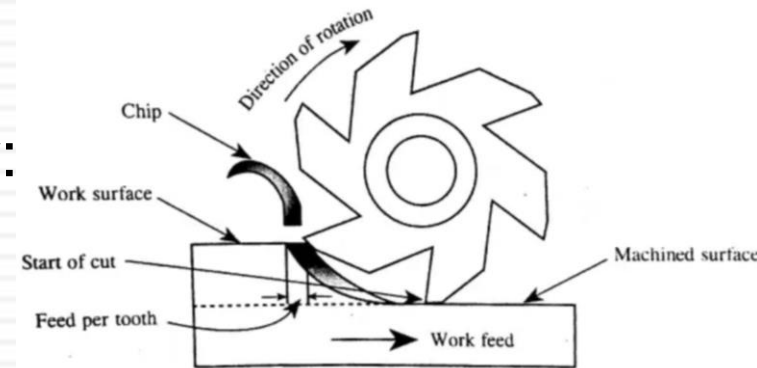

# Milling and Milling Machines:

## Peripheral Milling

13

### Milling Parameters

- $f$ : distance workpiece travels per tooth of cutter:

$$f = \frac{v}{Nn}$$

- Note, dimensional accuracy can be checked:

$$[mm/tooth] = [mm/min] / [rev/min] [num. of teeth/rev]$$

- Cutting time is given by:

$$t = \frac{l + l_c}{v}$$

- Note,  $l_c$ : horizontal extent of cutter's first contact with workpiece
- $l_c$  can be approximated using:

$$l_c = \sqrt{d(D - d)}$$

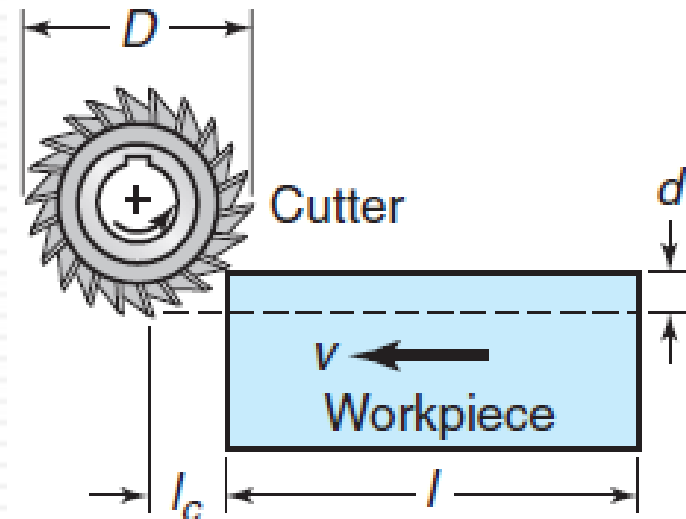

# Milling and Milling Machines:

## Peripheral Milling

14

### Milling Parameters

- Assuming  $l_c \ll l \Rightarrow$  MRR is given by:

$$MRR = \frac{lwd}{t} = wdv$$

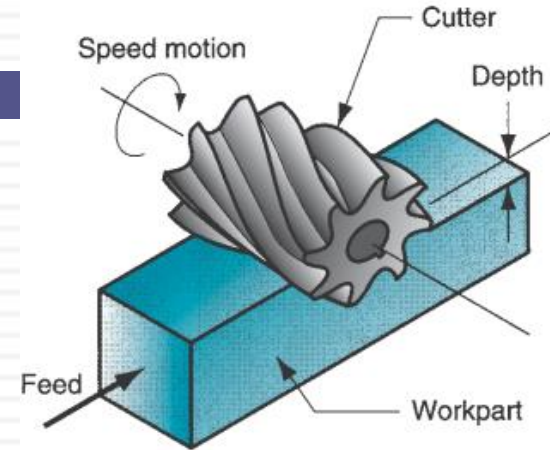

- Note, in slab milling:  $w$  is same as  $w$  of workpiece
- Also, as with turning, non-cutting time should be minimized
- Power requirement and torque on spindle:
  - Calculated similar to technique used in drilling
  - Note, forces on cutter (tangential, radial, axial):
    - Difficult to calculate (since many variables are involved)
    - Many variables related to cutting-tool geometry
  - $Torque = \text{tangential force } (F_c) * \text{cutter radius } (D/2)$ 
    - Note,  $F_c$  per tooth depends on # of teeth engaged during cutting

# Milling and Milling Machines:

## Peripheral Milling

15

### Summary of Peripheral Milling Parameters and Formulas

$N$  = Rotational speed of the cutter, rpm

$F$  = Feed, *mm/rev*

$D$  = Cutter diameter, mm

$n$  = Number of teeth on cutter

$v$  = Linear speed of the workpiece or feed rate, mm/min

$V$  = Surface speed of cutter m/min

$$= \pi DN$$

$f$  = Feed per tooth, mm/tooth

$$= v/Nn$$

$$t_c = 2f \sqrt{\frac{d}{D}}$$

$$l_c = \sqrt{d(D - d)}$$

$l$  = Length of cut, mm

$t$  = Cutting time, s or min

$= (l + l_c)/v$ , where  $l_c$  = extent of the cutter's first contact with the workpiece

MRR = mm<sup>3</sup>/min

$= wdv$ , where  $w$  is the width of cut

Torque = N · m

$$= F_c D/2$$

Power = kW

$= (\text{Torque})(\omega)$ , where  $\omega = 2\pi N$  radians/min

# Milling and Milling Machines:

## Peripheral Milling

16

### EXAMPLE 24.1

#### Material-removal Rate, Power, Torque, and Cutting Time in Slab Milling

A slab-milling operation is being carried out on a 300-mm-long, 100-mm-wide annealed mild-steel block at a feed  $f$  0.25 mm/tooth and a depth of cut  $d$  3.0 mm. The cutter is  $D=50$  mm in diameter, has 20 straight teeth, rotates at 100rpm and, by definition, is wider than the block to be machined. Calculate the material-removal rate, estimate the power and torque required for this operation, and calculate the cutting time.

# Milling and Milling Machines: Peripheral Milling

17

## Solution

### Material-removal Rate, Power, Torque, and Cutting Time in Slab Milling

The linear speed of the workpiece is

$$v = fNn = (0.25)(100)(20) = 500 \text{ mm/min}$$

The material-removal rate is

$$MMR = (100)(3)(500) = 150,000 \text{ mm}^3 / \text{min}$$

The power required is

$$Power = (3)(150,000)\left(\frac{1}{60}\right) = 7.5 \text{ kW}$$

# Milling and Milling Machines:

## Peripheral Milling

18

### Solution

#### Material-removal Rate, Power, Torque, and Cutting Time in Slab Milling

The torque acting on the cutter spindle is

$$\text{Torque} = \frac{\text{Power}}{\text{Rotational Speed}} = \frac{(7500)(60)}{(100)(2\pi)} = 716 \text{ Nm}$$

The cutting time is

$$t = \frac{300 + \sqrt{Dd}}{500} = \frac{300 + \sqrt{(50)(3)}}{500} = 0.62 \text{ min} = 37.2 \text{ s}$$

# Milling and Milling Machines:

## Face Milling

19

- Face milling cutter:
  - ▣ Mounted on a spindle
  - ▣ Axis of rotation:  $\perp$  to workpiece surface
  - ▣ Removes material in manner shown ( $\rightarrow$ )
  - ▣ Cutting teeth:
    - Example: carbide inserts
    - Mounted on the cutter body
  
- ▣ Cutter: rotates at rotational speed,  $N$
- ▣ Workpiece: moves along straight path at linear speed,  $v$
- ▣ Rotates as:  
climb or conventional milling ([next slide](#))

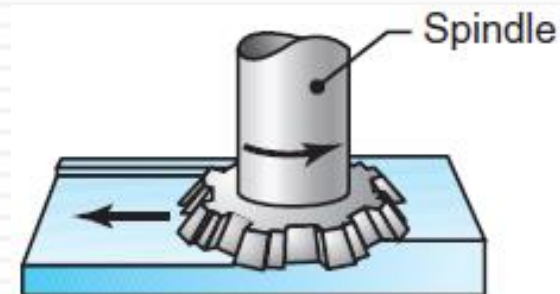
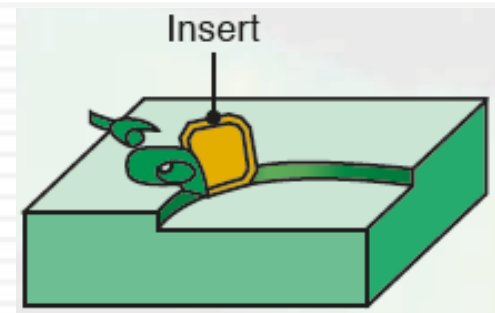

(b) Face milling

# Milling and Milling Machines:

## Face Milling

20

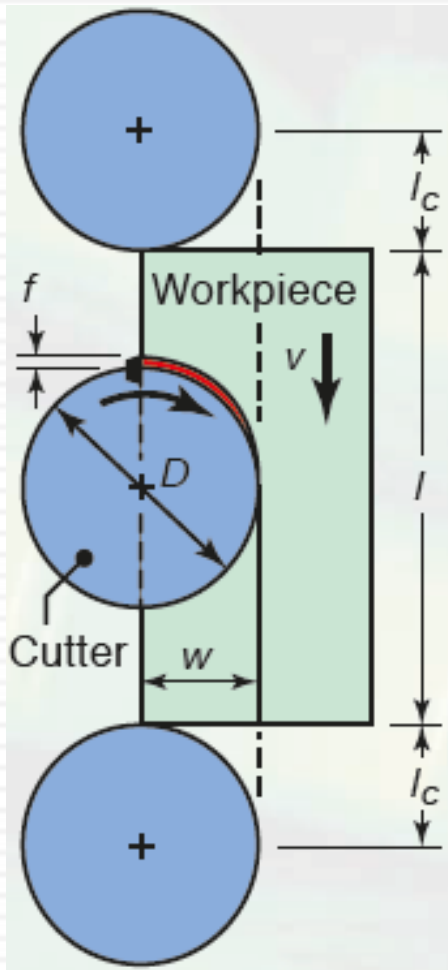

**Climb milling**

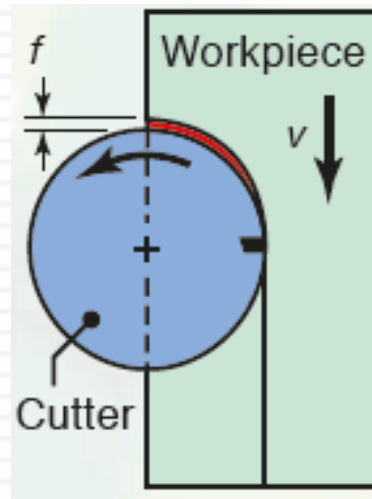

**Conventional milling**

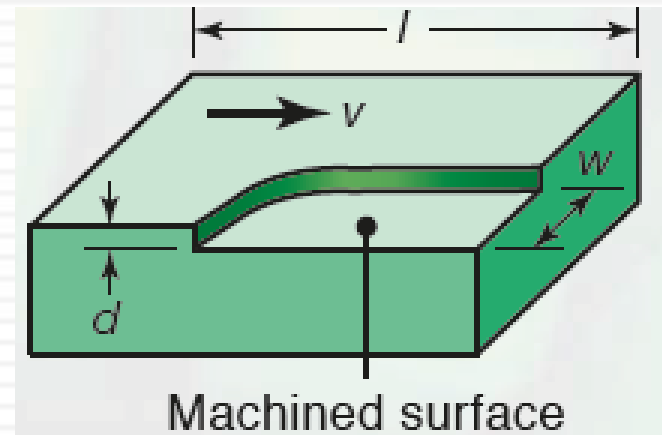

**Machined surface**

**Dimensions in face milling**  
 (note, width of cut,  $w$ , is not necessarily the same as cutter radius,  $D/2$ )

Note,

$l_c$  can be approximated using:  $l_c = \sqrt{w(D - w)}$

$D:w$  ratio should be no less than 3:2 (typical face milling)

# Milling and Milling Machines:

## Face Milling

21

- Relative motion between cutter teeth and workpiece  $\Rightarrow$  **feed marks** on machined surface ( $\downarrow$ )
  - ▣ Note, these marks are similar to those left by turning
  - ▣ Roughness of workpiece depends on: corner geometry and  $f$

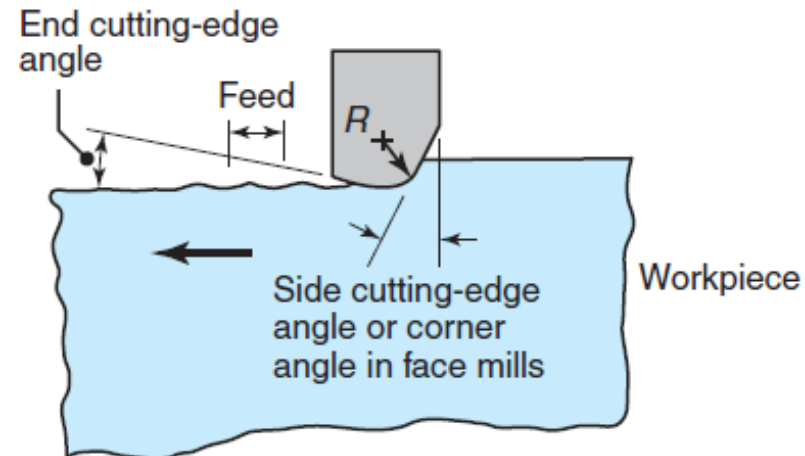
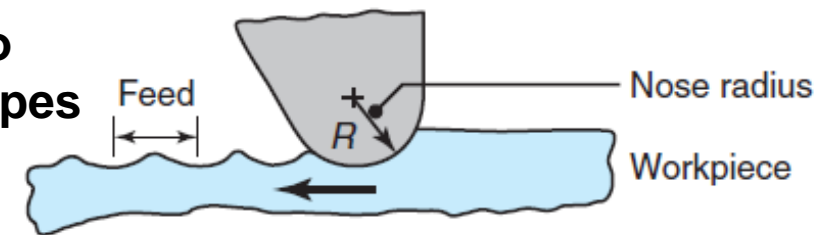
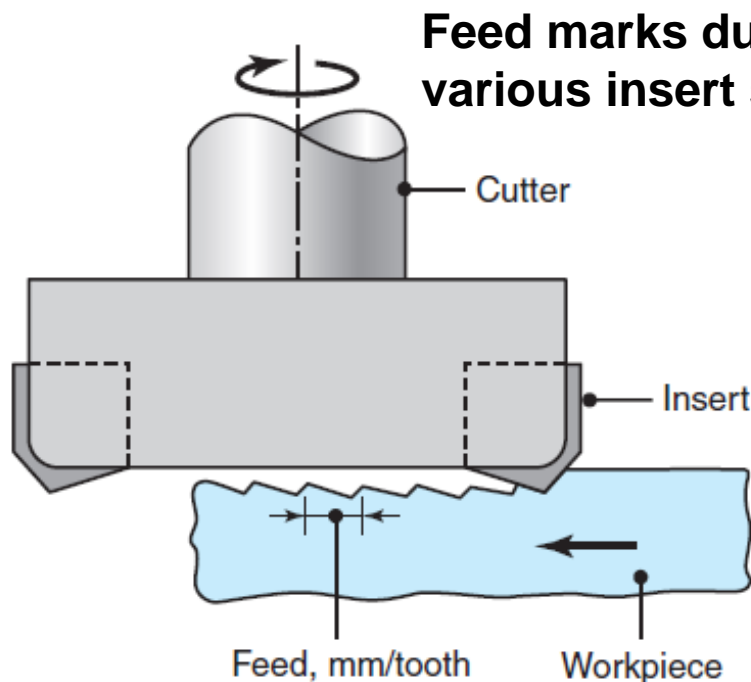

# Milling and Milling Machines:

## Face Milling

22

- Face-milling cutter: terminology and various angles:
  - ▣ 2 cutting angles (side/corner and end)
  - ▣ 2 rake angles (axial and radial)
  - ▣ 2 relief angles (axial and radial)

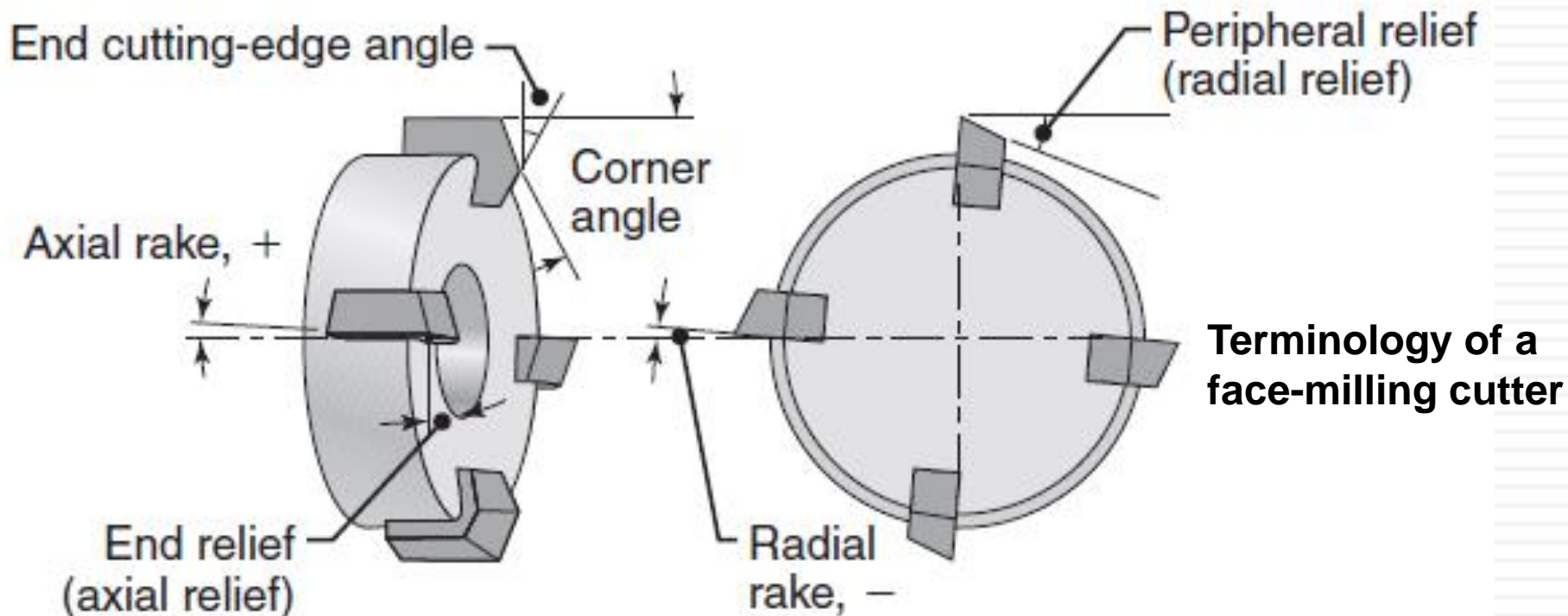

# Milling and Milling Machines:

## Face Milling

23

- **Lead angle:** of insert in face milling
  - ▣ Has direct influence on the **undeformed chip thickness**,  $t_c$
  - ▣ As lead angle  $\uparrow$ 
    - $\Rightarrow t_c \downarrow$  ( $\Rightarrow$  chip thickness  $\downarrow$ )
    - but length of contact ( $\Rightarrow$  width of chip):  $\uparrow$
    - but cross-sectional area of  $t_c$  remains constant
  - ▣ Lead angles usually:  $0^\circ - 45^\circ$
  - ▣ Note, insert must be large to accommodate  $\uparrow$  in contact length

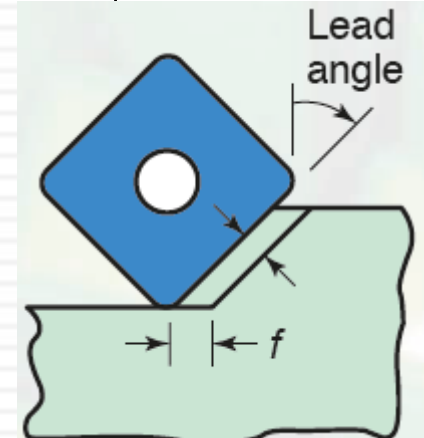
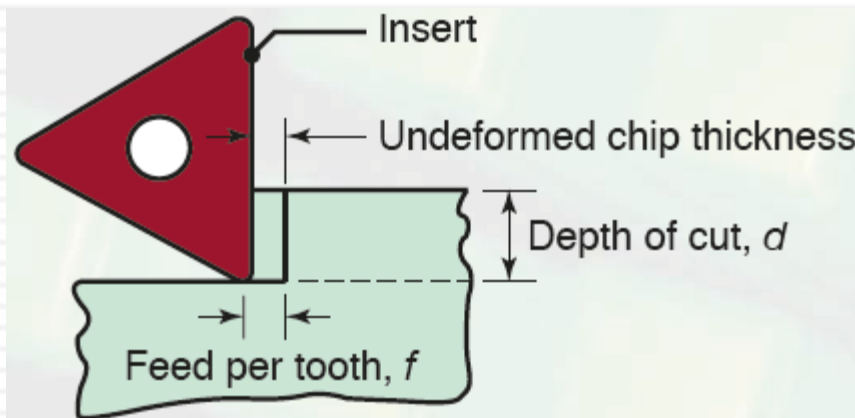

# Milling and Milling Machines:

## Face Milling

24

- Relation between cutter and workpiece (↓):
  - ▣ This determines angle at which insert *enters* & *exits* workpiece

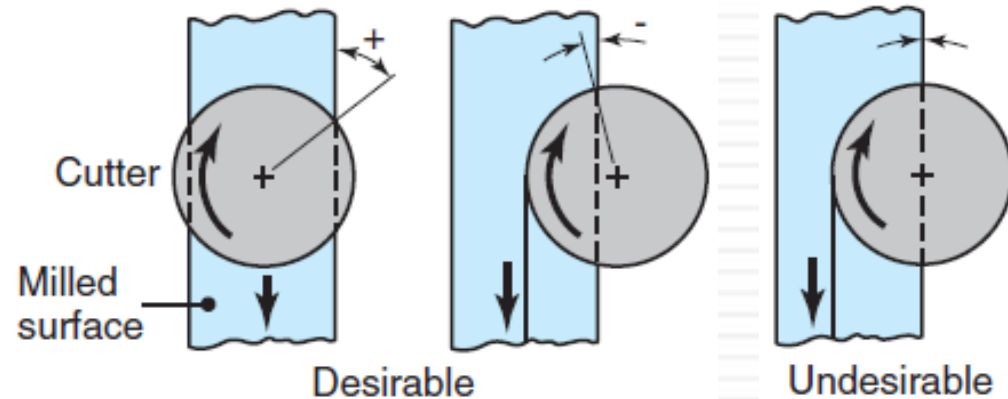
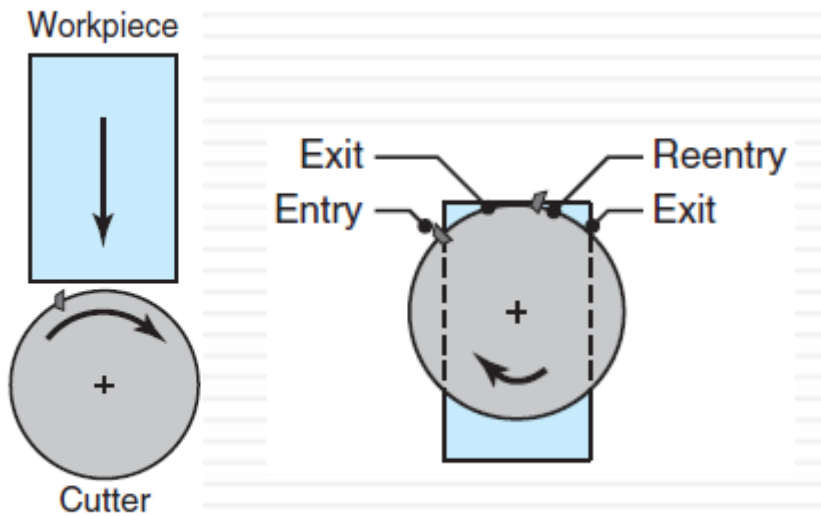

**Tip of insert makes first contact** (⇒ possible for cutting edge to chip off)

**First contact is at an angle, away from insert tip** (⇒ lower tendency of insert to fail)

**Insert exits workpiece at an angle** (⇒ force on insert reduces to zero at a slow rate)

**Insert exits workpiece suddenly** (undesirable for tool life)

# Milling and Milling Machines:

## Face Milling

25

### EXAMPLE 24.2

#### Material-removal Rate, Power Required, and Cutting Time in Face Milling

Assume that  $D = 150$  mm,  $w = 60$  mm,  $l = 500$  mm,  $d = 3$  mm,  $v = 0.6$  m/min and  $N = 100$  rpm. The cutter has 10 inserts, and the workpiece material is a high-strength aluminum alloy. Calculate the material-removal rate, cutting time, and feed per tooth, and estimate the power required.

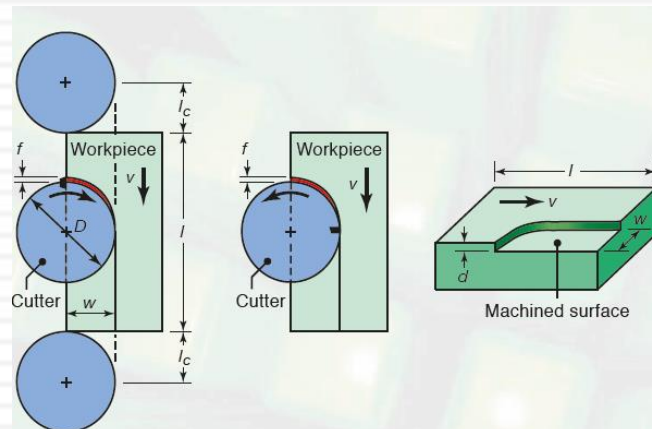

# Milling and Milling Machines:

## Face Milling

26

### Solution

#### Material-removal Rate, Power Required, and Cutting Time in Face Milling

The material-removal rate is

$$MMR = (180)(600) = 108,000 \text{ mm}^3 / \text{min}$$

The cutting time is  $t = \frac{l + 2l_c}{v} = \frac{500 + 2(75)}{10} = 65 \text{ s} = 1.08 \text{ min}$

The feed per tooth is  $f = \frac{10}{(1.67)(10)} = 0.6 \text{ mm/tooth}$

The power is  $Power = (1.1)(1800) = 1980 \text{ W} = 1.98 \text{ kW}$

# Milling and Milling Machines:

## End Milling

27

- End milling:
  - ▣ Important and common machining process
  - ▣ Versatile: produces various profiles, curved surfaces

- Cutter (aka **end mill**):
  - ▣ Has straight shank, or
  - ▣ Tapered shank (for larger sizes)
  - ▣ Mounted into spindle of milling machine
  - ▣ Made of HSS or carbide inserts (like face milling)
  - ▣ Usually rotates on axis  $\perp$  to workpiece surface
  - ▣ Can be tilted to conform to curved surfaces

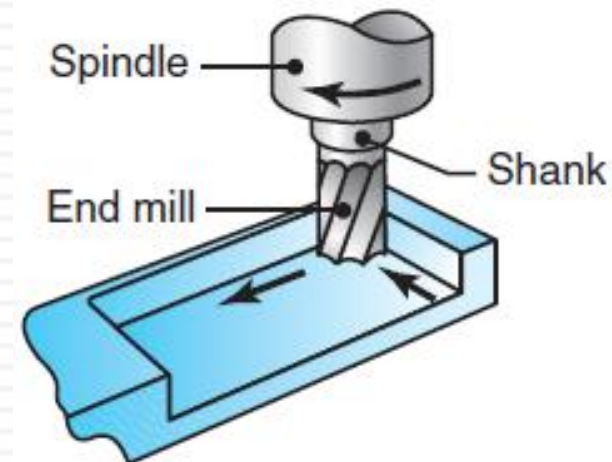

# Milling and Milling Machines:

## End Milling

28

- Cont. end mills:
  - Available with hemispherical ends (aka ball nose mills →)
  - Can produce variety of surfaces, at any depth
  - Used in machining dies and molds
  - Examples:  
curved, stepped, pocketed surfaces (→)
  - Can remove material on both end and cylindrical cutting edges

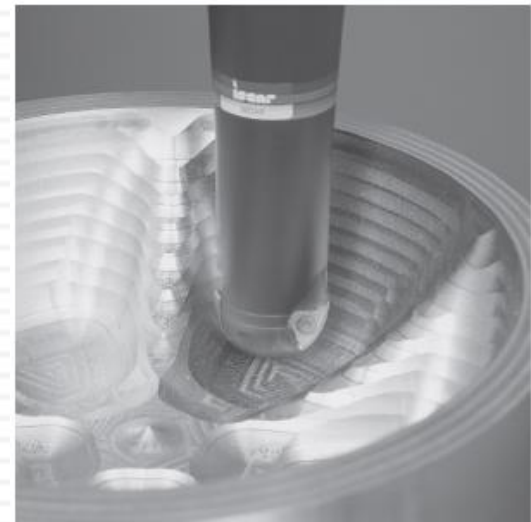

# Milling and Milling Machines: Other Milling Operations and Milling Cutters

29

- **Straddle milling:**
  - ▣ Two or more cutters: mounted on an arbor
  - ▣ Used to machine 2 // surfaces on workpiece
  
- **Form milling:**
  - ▣ Produces curved profiles
  - ▣ Uses cutters with specially shaped teeth
  - ▣ Also used for cutting gear teeth

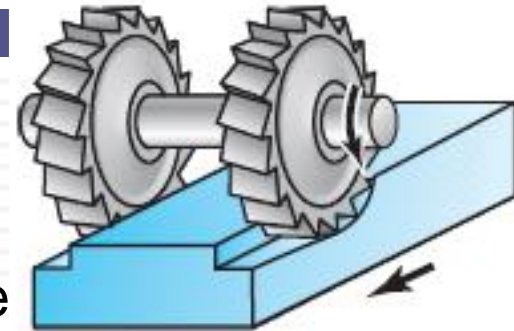

(a) Straddle milling

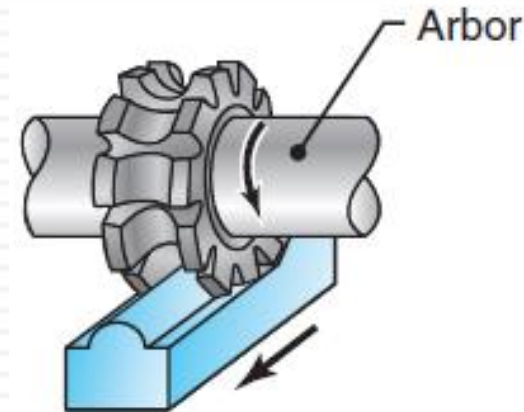

(b) Form milling

# Milling and Milling Machines: Other Milling Operations and Milling Cutters

30

- **Slotting & Slitting operations:**
  - ▣ Performed with circular cutters
  - ▣ Slitting saws: thin (usu.  $< 5\text{ mm}$ )

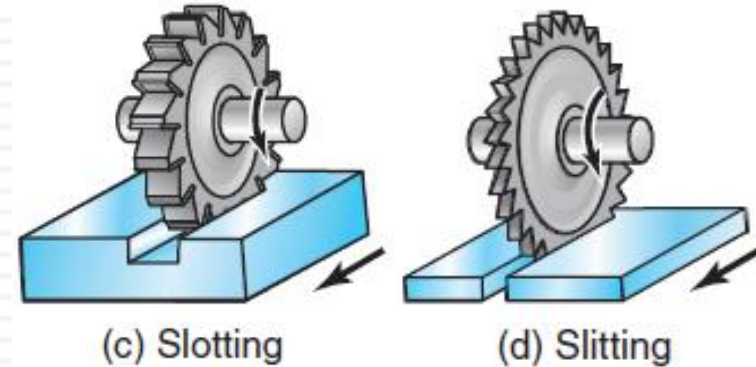

- **T-slot cutters:**
  - ▣ Used to mill T-slots
  - ▣ Application: machine-tool worktables for [clamping workpieces](#)
  - ▣ Step 1: slot is milled with end mill
  - ▣ Step 2: cutter machines profile of T-slot in one pass

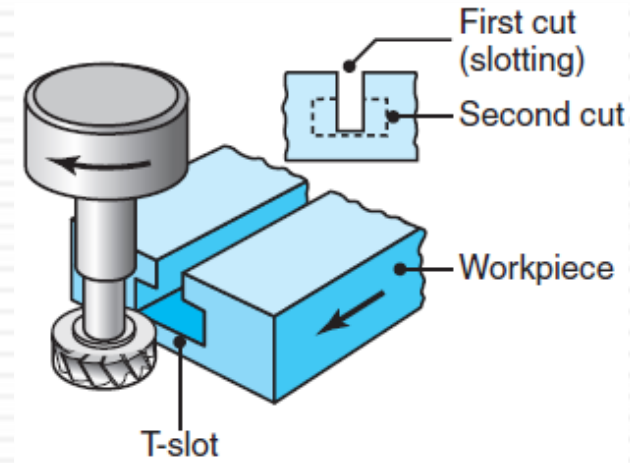

# Milling and Milling Machines:

## Milling Process Capabilities

31

- [Table 24.2](#) shows (for milling), conventional ranges of:
  - ▣ Speeds (vary widely: 30 – 3000 *m/min*)
  - ▣ Feed per tooth (typically: 0.1 – 0.5 *mm*)
  - ▣ Depths of cut (usually: 1 – 8 *mm*)
- Note, large range of values shown is due to variance in:
  - ▣ Workpiece material
  - ▣ Workpiece condition
  - ▣ Cutting-tool material
  - ▣ Process parameters
- Note, cutting fluid recommendations:
  - ▣ Same as those used with turning/hole making operations

## General Recommendations for Milling Operations

Material	Cutting tool	General-purpose starting conditions		Range of conditions	
		Feed mm/tooth	Speed m/min	Feed mm/tooth	Speed m/min
Low-carbon and free-machining steels	Uncoated carbide, coated carbide, cermets	0.13–0.20	120–180	0.085–0.38	90–425
Alloy steels					
Soft	Uncoated, coated, cermets	0.10–0.18	90–170	0.08–0.30	60–370
Hard	Cermets, PcBN	0.10–0.15	180–210	0.08–0.25	75–460
Cast iron, gray	Uncoated, coated, cermets, SiN	0.10–10.20	120–760	0.08–0.38	90–1370
Soft					
Hard	Cermets, SiN, PcBN	0.10–0.20	120–210	0.08–0.38	90–460
Stainless steel, Austenitic	Uncoated, coated, cermets	0.13–0.18	120–370	0.08–0.38	90–500
High-temperature alloys	Uncoated, coated, cermets, SiN, PcBN	0.10–0.18	30–370	0.08–0.38	30–550
Nickel based					
Titanium alloys	Uncoated, coated, cermets	0.13–0.15	50–60	0.08–0.38	40–140
Aluminum alloys					
Free machining	Uncoated, coated, PCD	0.13–0.23	610–900	0.08–0.46	300–3000
High silicon	PCD	0.13	610	0.08–0.38	370–910
Copper alloys	Uncoated, coated, PCD	0.13–0.23	300–760	0.08–0.46	90–1070
Plastics	Uncoated, coated, PCD	0.13–0.23	270–460	0.08–0.46	90–1370

Source: Based on data from Kennametal Inc.

Note: Depths of cut,  $d$ , usually are in the range of 1 to 8 mm. PcBN: polycrystalline cubic-boron nitride. PCD: polycrystalline diamond. See also Table 23.4 for range of cutting speeds within tool material groups.

# Milling and Milling Machines:

## Design and Operating Guidelines for Milling

33

- Additional factors relevant to milling operations include:
  - Standard milling cutters should be used as much as possible
  - Chamfers should be specified (instead of radii)
  - Internal cavities, pockets with sharp corners should be avoided
  - Proper clearance should be provided in design for milling cutters
  - Workpieces should be rigid to minimize deflections
  
- Guidelines for avoiding vibration and chatter in milling:
  - Cutters should be mounted close to spindle base
  - Toolholders and fixturing devices should be rigid
  - In case of vibration/chatter: use cutter with fewer cutting teeth

# Milling and Milling Machines:

## Milling Machines

34

- Milling machines:
  - ▣ Among most versatile/useful machine tools
  - ▣ First milling machines: 1820 (Eli Whitney)
  - ▣ Machines today have many features
  - ▣ Standard milling machines now being replaced with computer controls and machining centers
  - ▣ Manually controlled machines: inexpensive, still used today for small production
  - ▣ Typical machines are described in upcoming slides

# Milling and Milling Machines:

## Milling Machines

35

### Column-and-knee-type Machines

- Used for general-purpose milling operations
- Most common milling machines
- Spindle on which cutter is mounted may be either ([next](#)):
  - ▣ Horizontal (for peripheral milling)
  - ▣ Vertical (for face and end milling, boring, drilling)
- Usually have 3 axes of movement
  - ▣ aka plain milling machines
  - ▣ Motion takes place manually or powered

# Milling and Milling Machines:

## Milling Machines

36

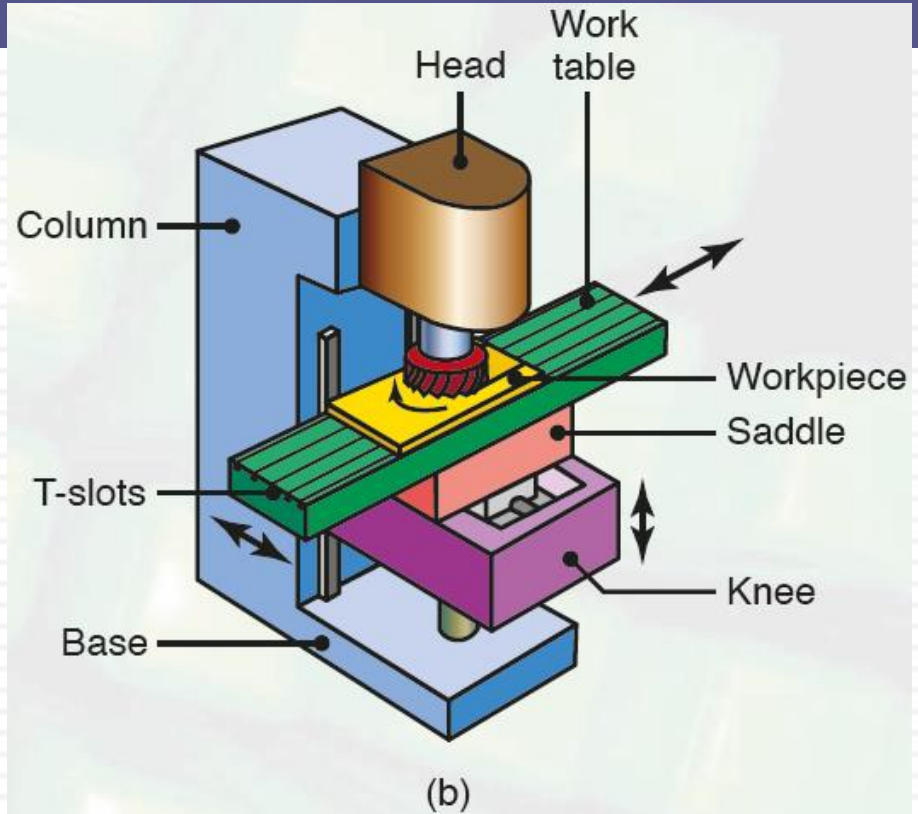
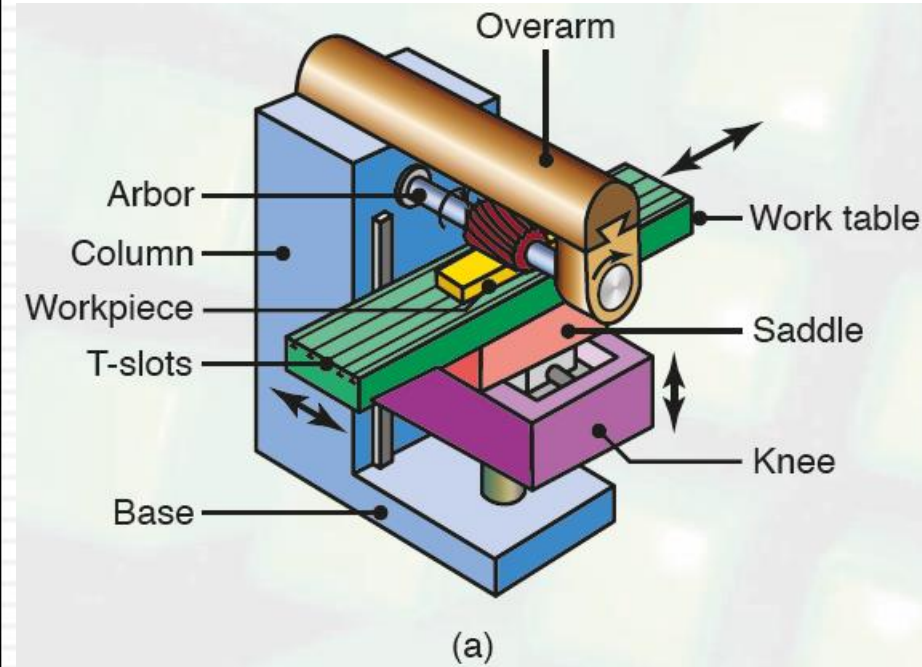

**Fig. 24.15** (a) Schematic illustration of a horizontal-spindle column-and-knee-type milling machine. (b) Schematic illustration of a vertical-spindle column-and-knee-type milling machine. *Source: After G. Boothroyd.*

# Milling and Milling Machines:

## Milling Machines

37

### Bed-type Milling Machines

- Worktable replaces knee
- Can move only longitudinally

### Other Types of Milling Machines

- Planer-type milling machines:
  - ▣ Have several heads and cutters to mill different surfaces
- Computer numerical-control (CNC) machines (→):
  - ▣ Used for high production quantities
  - ▣ Capable of: milling, drilling, boring, tapping

