

# **MILLING OPERATION**

Lecture-06

# Milling operation

- Milling is a machining operation in which a workpiece is feed past a **rotating cylindrical tool with multiple cutting edges**.
- This cutting tool in milling is known as milling cutter and the machine tool that traditionally performs the operation is called milling machine.
- Milling is an **interrupted cutting operation**, the teeth of milling cutter enter and exit the work during each revolution.

[https://www.youtube.com/watch?v=9\\_iOGGC70mQ](https://www.youtube.com/watch?v=9_iOGGC70mQ)

<https://www.youtube.com/watch?v=v4pWjZbTORI>

# Milling operation

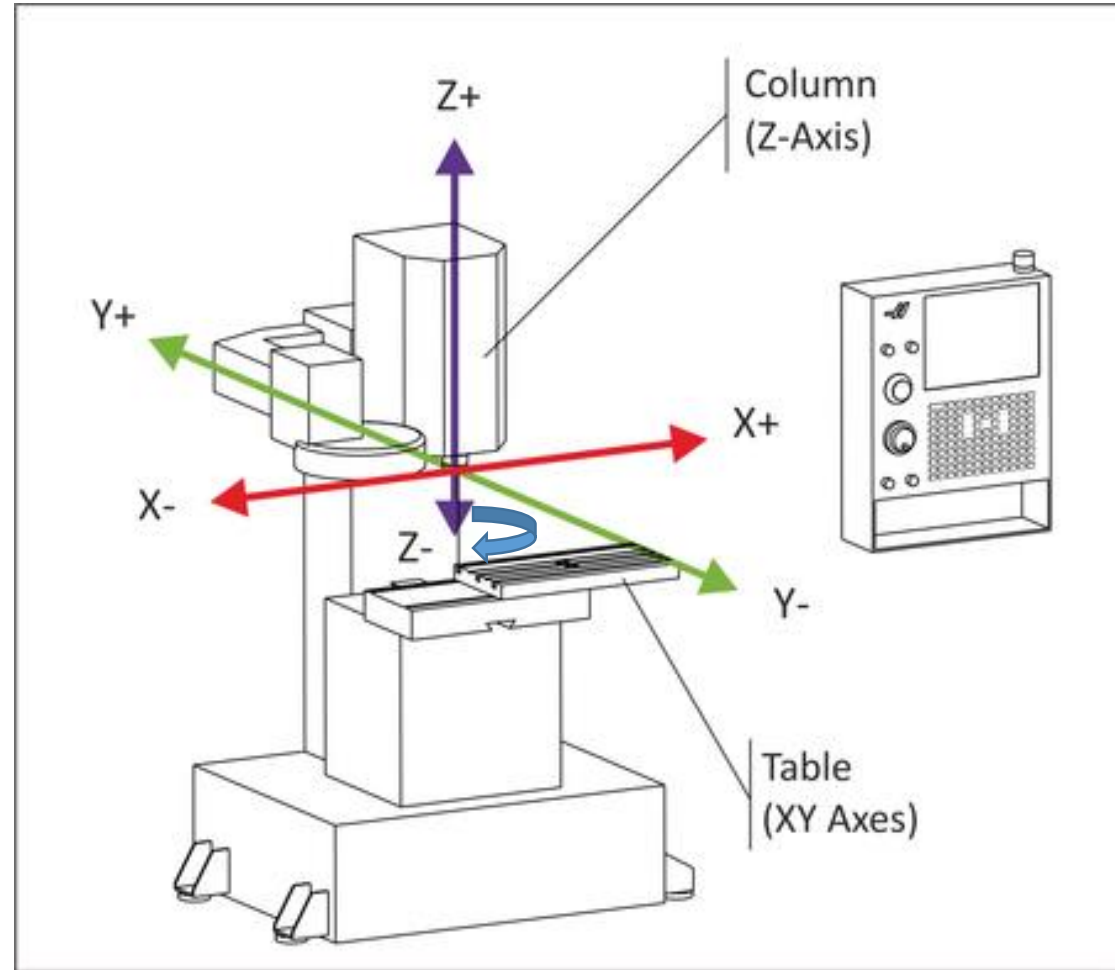

<https://www.youtube.com/watch?v=CqePrbeAQoM>

# Milling operation

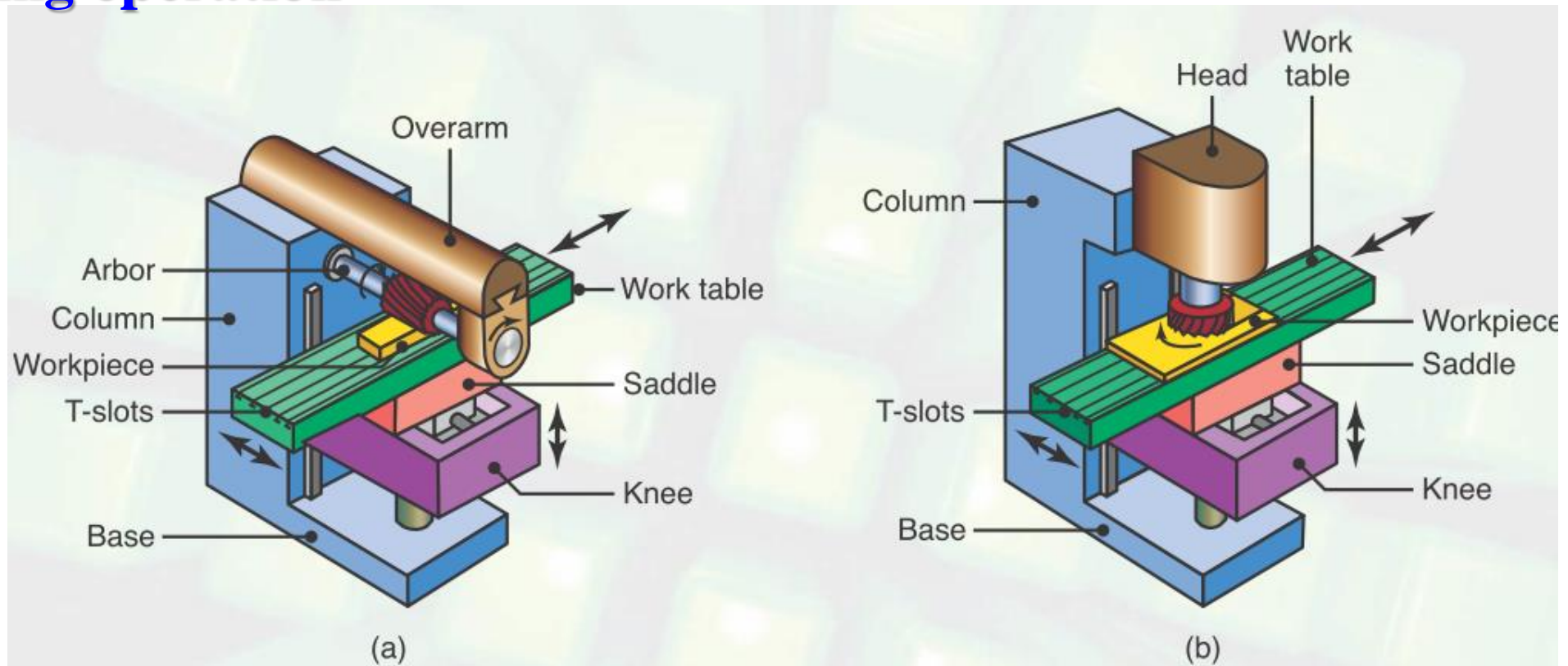

FIGURE 8.59 (a) Schematic illustration of a horizontal-spindle column-and-knee-type milling machine. (b) Schematic illustration of a vertical-spindle column-and-knee-type milling machine. Source: After G. Boothroyd.

# Types of milling operations

There are two basic types of milling operations **peripheral or slab milling (horizontal milling)** and **face milling (vertical milling)**.

## Peripheral or slab milling

In this milling operation the axis of tool is parallel to the surface being machined. In this operation there are two opposite directions of rotation that the cutter can have with respect to the work.

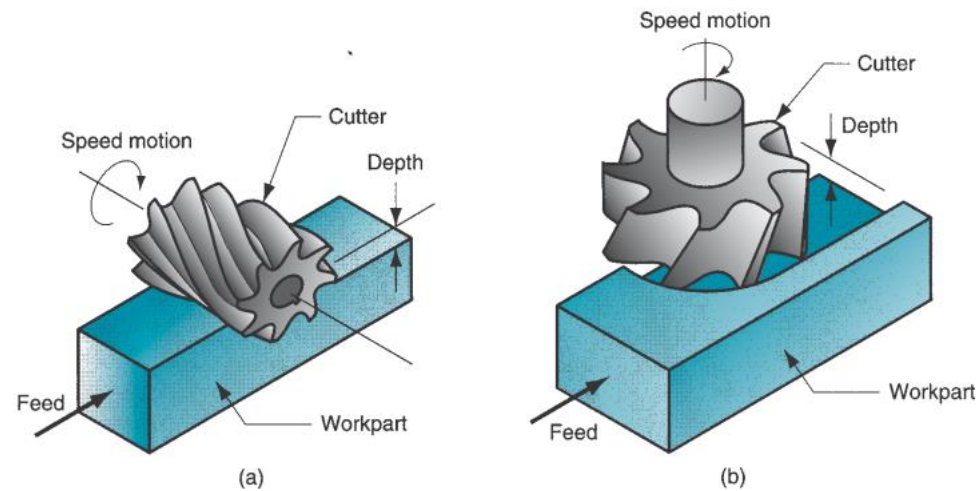

(a) Peripheral milling operation, (b) face milling

[https://www.youtube.com/watch?v=2y\\_OJv-K0E8](https://www.youtube.com/watch?v=2y_OJv-K0E8)

[Milling Operations \(Animation\) – YouTube](#)  
[Milling Operations \(Animation\) - YouTube](#)

# Peripheral or slab milling operations

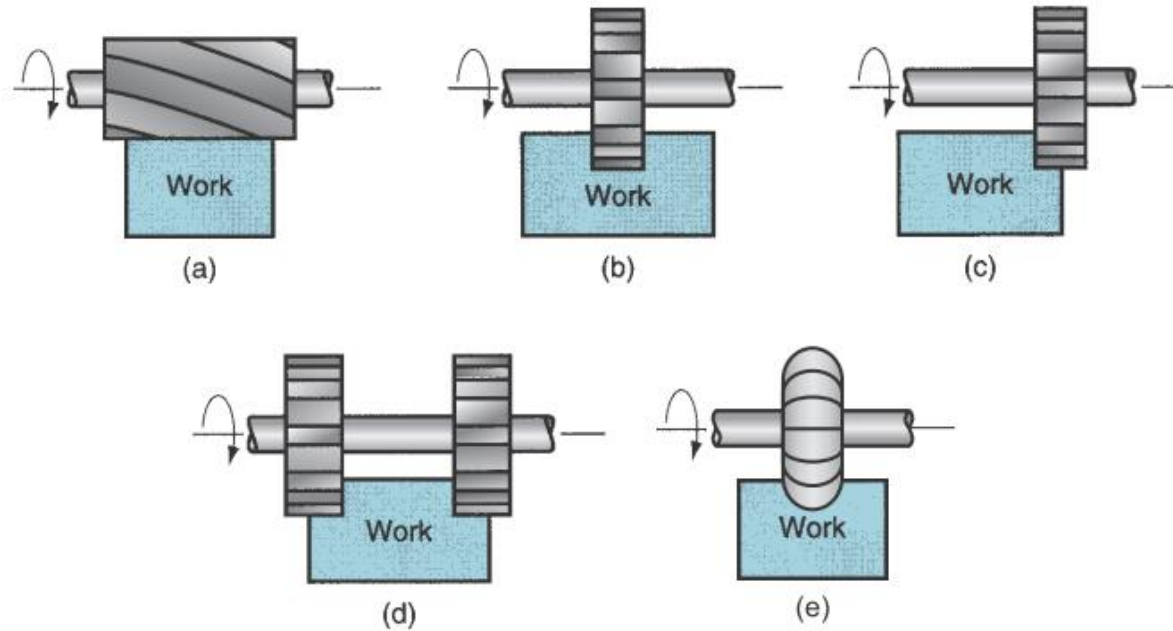

Peripheral milling: (a) slab milling, (b) slotting, (c) side milling, (d) straddle milling, and (e) form milling.

## Types of peripheral or slab milling

**Up milling:** In up milling the direction of motion of the cutter teeth is opposite to the feed direction. In this type of milling operation, the chip formed by each cutter tooth starts out very thin and increases in thickness during the sweep of the cutter. The chip length is longer than in down milling.

**Down milling:** In down milling, the direction of motion of the cutter teeth is same as the feed direction. In this operation each chip starts out thick and reduces in thickness throughout the cut.

# Types of peripheral or slab milling

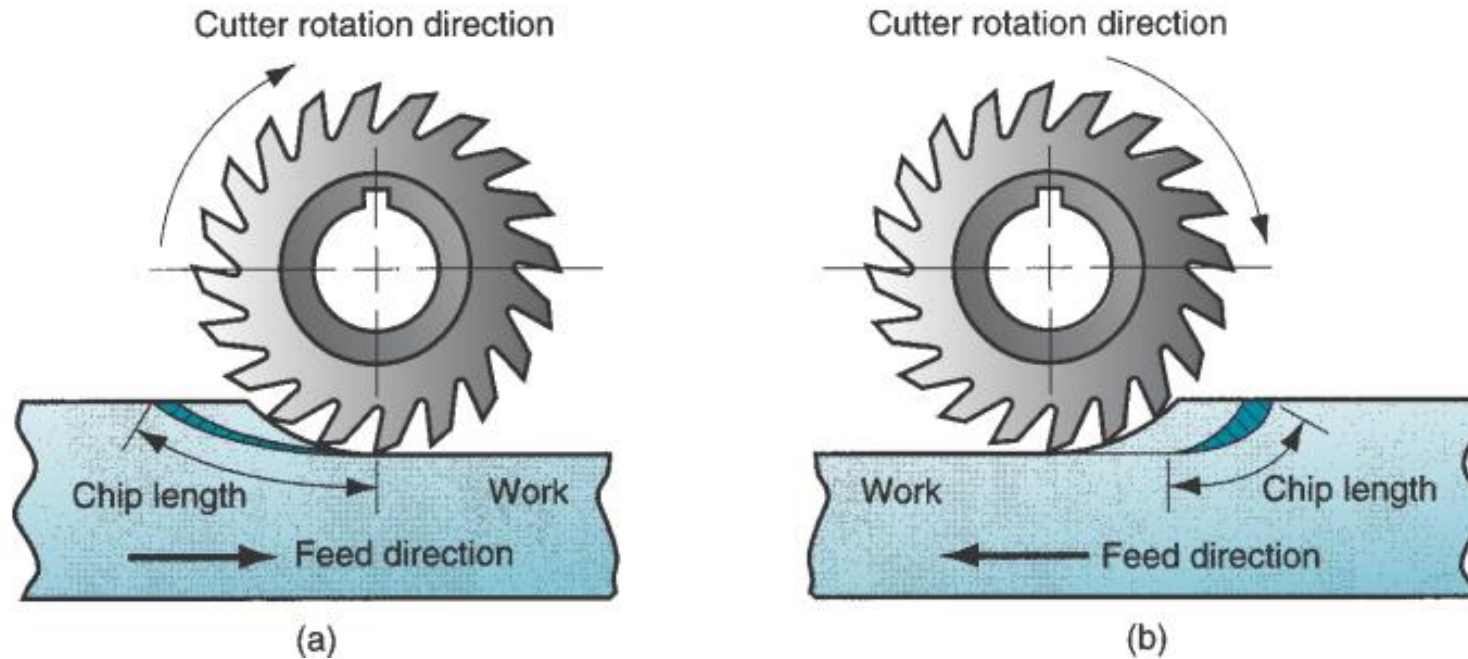

Two forms of peripheral milling operation with a 20-teeth cutter: (a) up milling, and (b) down milling.

<https://www.youtube.com/watch?v=ss475wvN1Qg>

# Face milling

In face milling the axis of the cutter is perpendicular to the surface being milled, as shown in the figure 6.5.

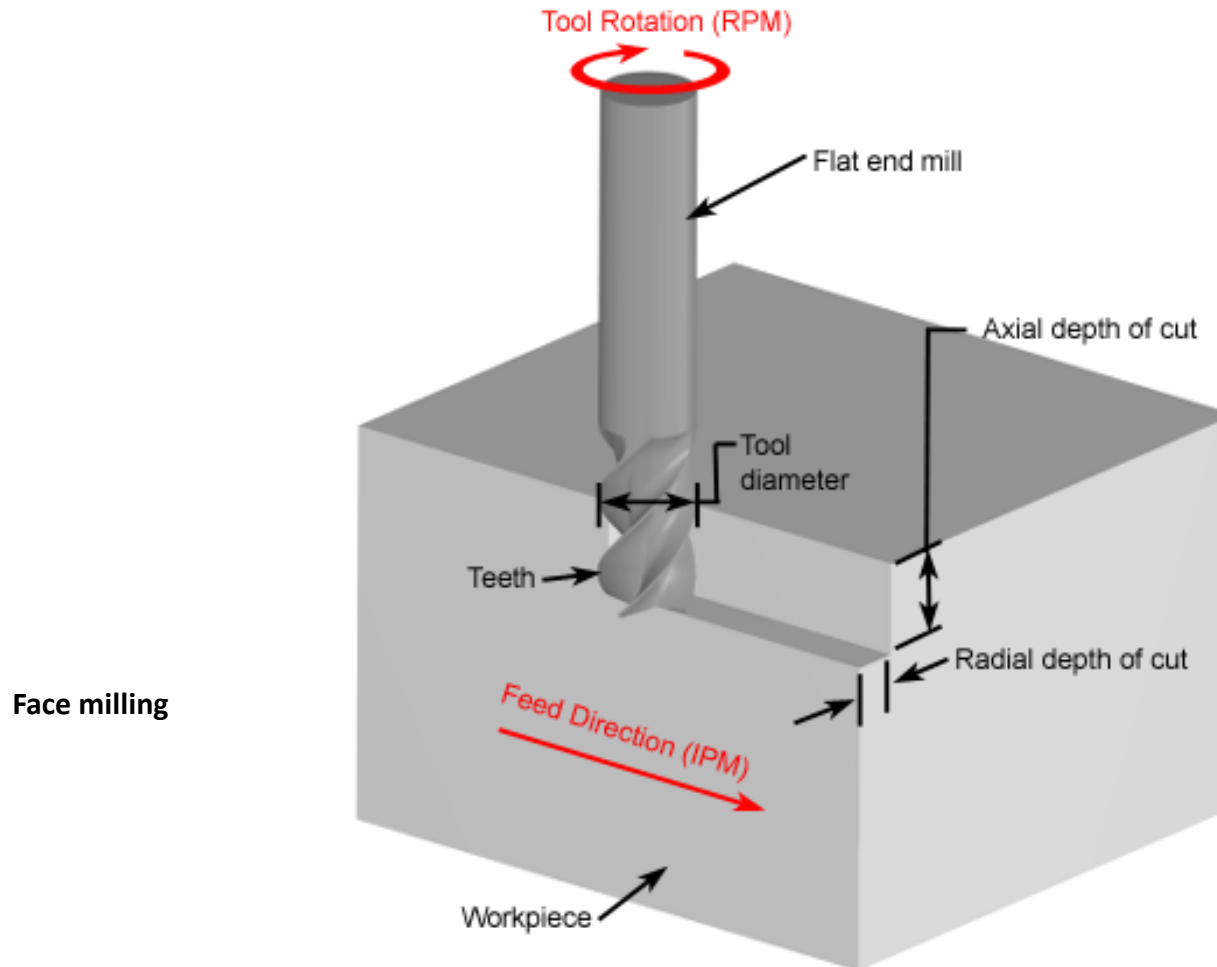

# Face milling operations

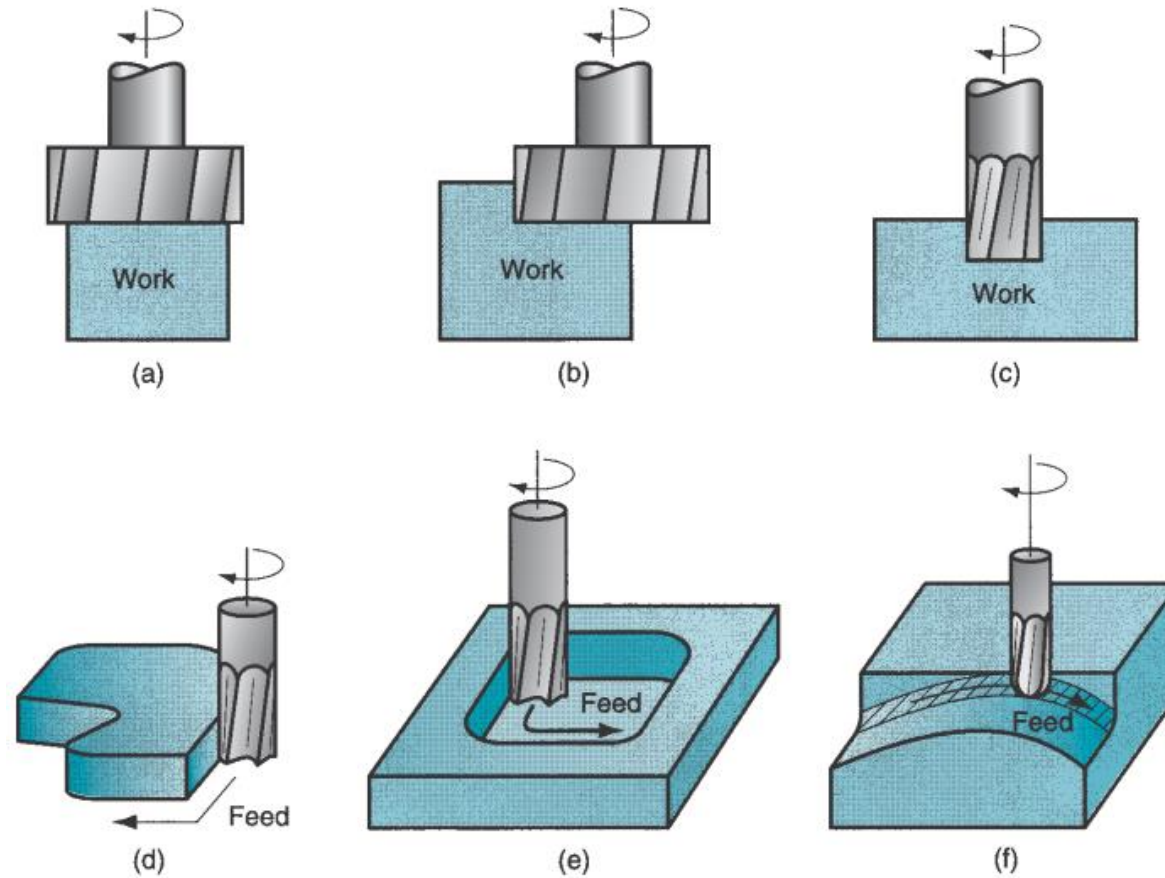

Face milling: (a) conventional face milling, (b) partial face milling, (c) end milling, (d) profile milling, (e) pocket milling, and (f) surface contouring.

# Cutting conditions in milling

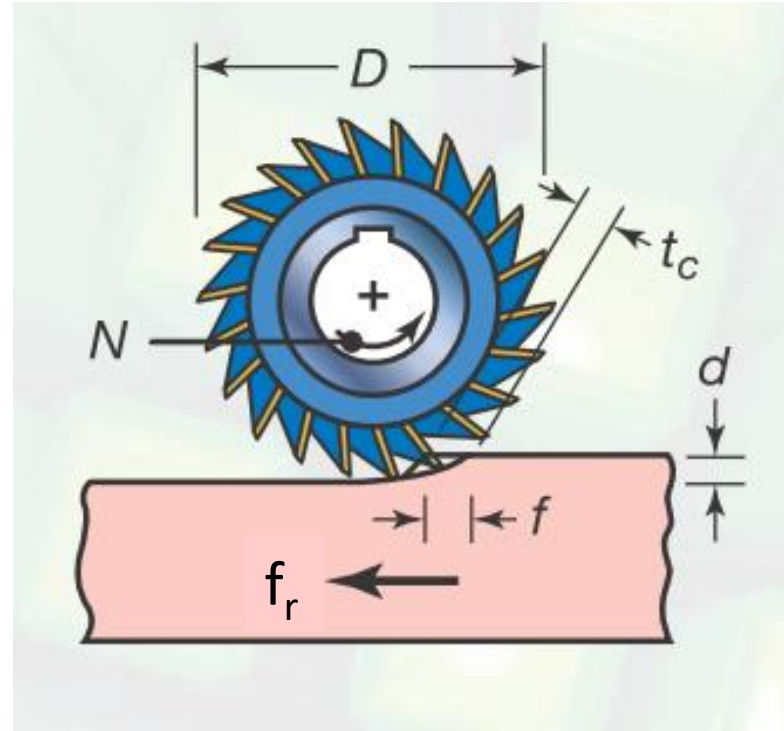

# Cutting conditions in milling

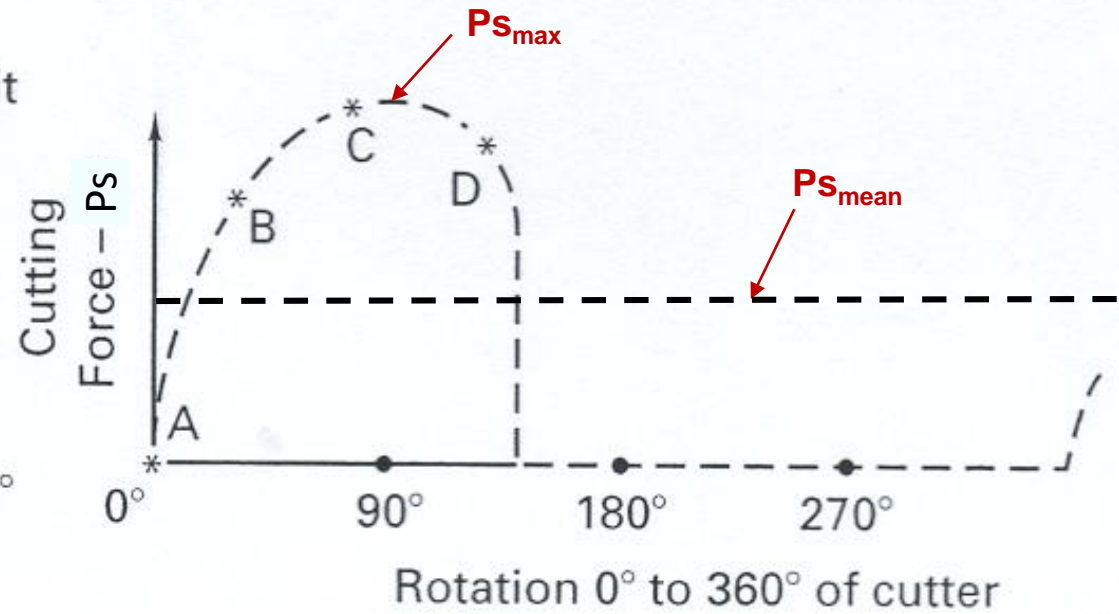
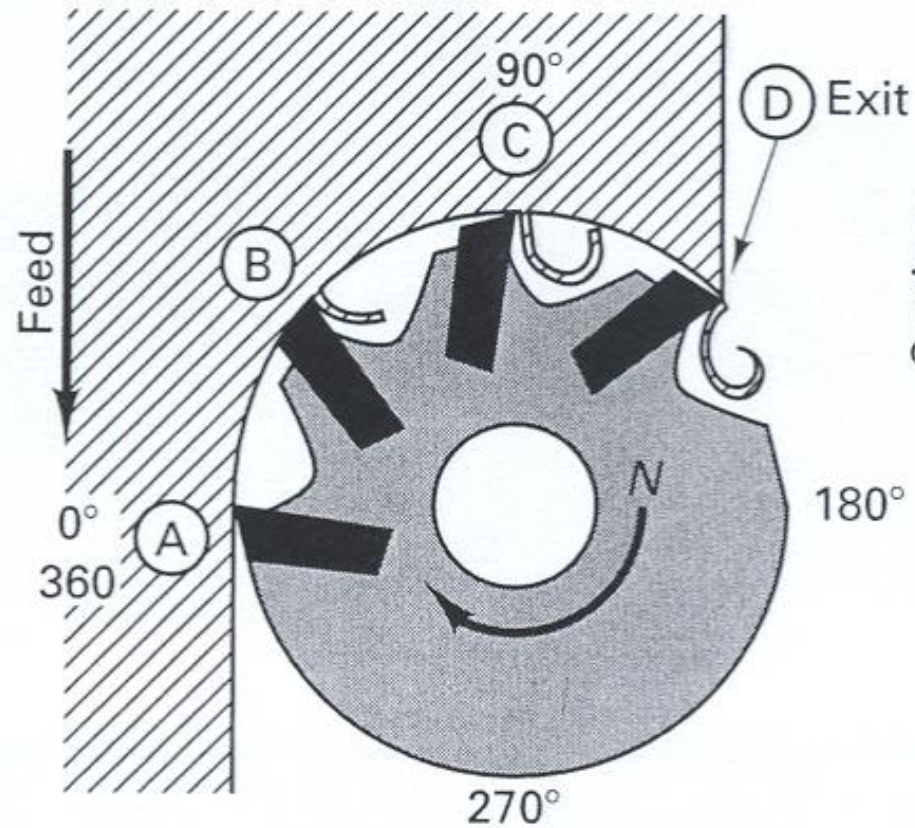

Conventional face milling with cutting force diagram for  $F_c$ , showing the **interrupted nature of process**.

## Cutting conditions in milling

The cutting speed is determined at the outside diameter of a milling cutter. This can be converted to spindle rotation speed.

$$N = \frac{V}{\pi D}$$

# Cutting conditions in milling

The milling operation is characterized by the **changing of chip thickness** as the cutting proceeds. Therefore the **maximum and mean values of chip thickness** are to be calculated.

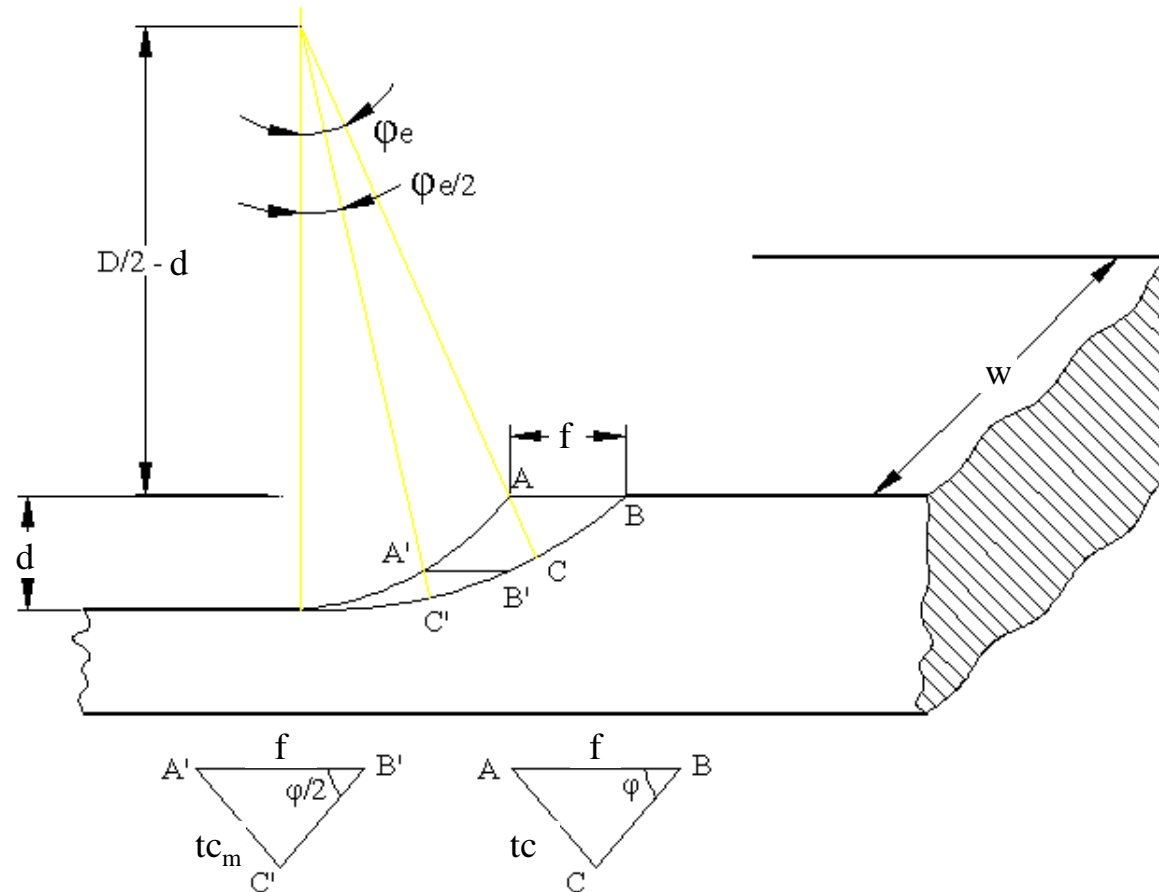

## Symbols key

$t_c$  = maximum chip thickness

$t_{c_m}$  = mean chip thickness

$f$  = feed rate in mm/tooth

$w$  = width of the cut

$D$  = diameter of the cutter

$d$  = depth of the cut

$\phi_e$  = engagement angle

Chip thickness ( $t_c$ ) detail in milling operation.

## Cutting conditions in milling

Since the **chip thickness** is an important factor for calculating the cutter forces and power, therefore the maximum and mean values of chip thickness will be calculated.

$$tc = f \sin \varphi_e = \frac{f_r}{N * z} * \sin \varphi_e$$

$$tc_m = \frac{tc}{2}$$

**Where**

f = feed of workpiece mm/tooth =  $f_r / (N * z)$

$\varphi_e$  = angle of rotation of milling cutter during which each tooth remains engaged in workpiece material

**$f_r$  = feed of workpiece in mm/min**

n = rotational speed of cutter in rpm

z = number of teeth on cutter

$$\sin \varphi_e = \frac{\sqrt{(D/2)^2 - (D/2 - d)^2}}{D/2} = 2\sqrt{d/D}$$

# Cutting conditions in milling

Substituting the values of  $\sin \varphi_e$

$$tc = \frac{2f_r}{N \times z} \sqrt{d / D}$$

$$tc_m = \frac{f_r}{N \times z} \sqrt{d / D}$$

# Cutting forces and power in milling

The resultant force  $R$  acting on a single tooth in peripheral milling operation can be resolved into tangential and radial components ( $P_s$ ,  $P_r$ ) or horizontal and vertical components ( $P_h$ ,  $P_v$ ).

**Therefore**

$$R = \sqrt{P_s^2 + P_r^2}$$

$$R = \sqrt{P_h^2 + P_v^2}$$

# Cutting forces and power in milling

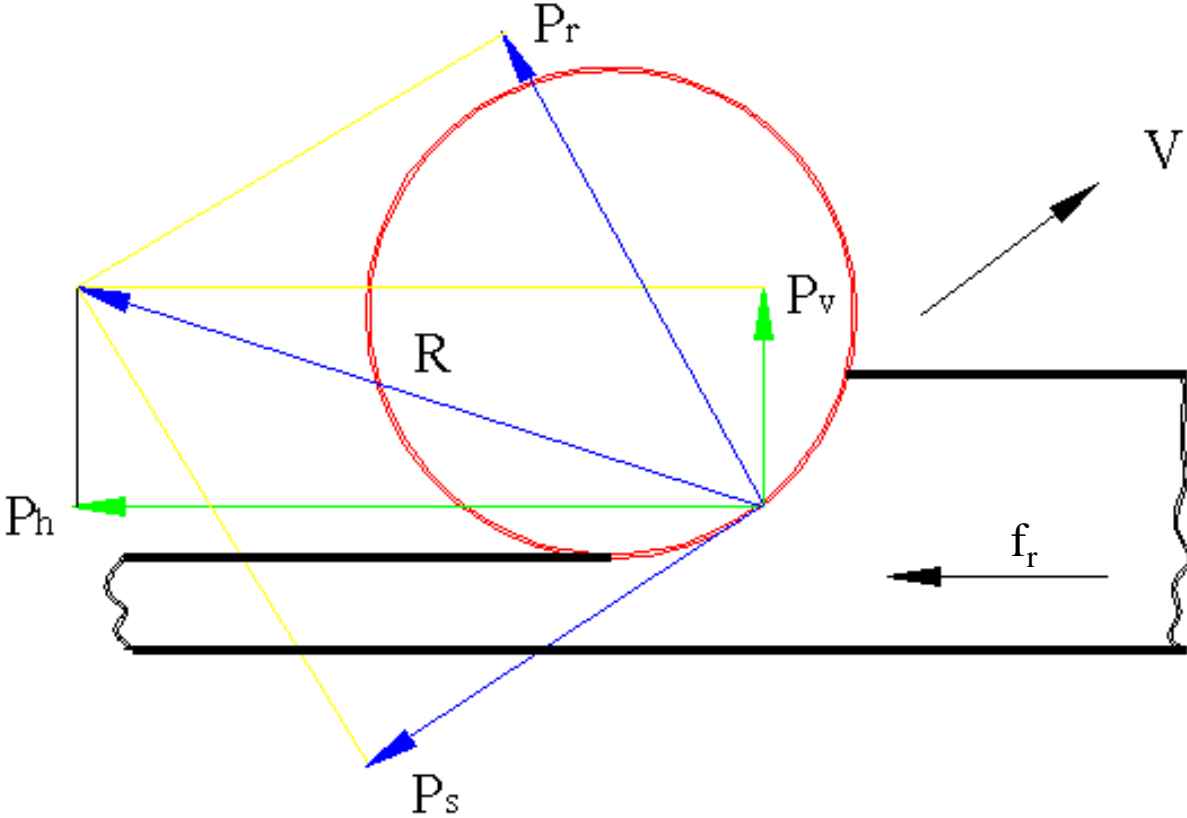

Cutting force components in milling operation

## The main cutting force “ $P_s$ ” in peripheral milling

$$P_s = K_s \times w \times t$$

$t$  = momentary chip thickness changing from zero to “ $t_c$ ” in up milling or from “ $t_c$ ” to zero in down milling (*use  $t_c$  for maximum cutting force calculation and  $t_{c_m}$  for mean for calculation*)

$w$  = width of the cut

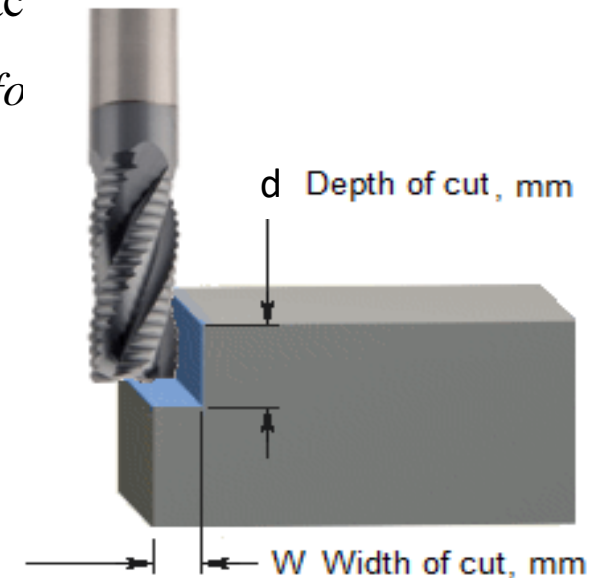

# Cutting forces and power in milling

$$P_{s \max} = K_s \times w \times tc$$

$$P_{s \max} = K_s \times w \frac{2f_r}{N * z} \times \sqrt{d / D}$$

$$P_{s \text{mean}} = K_s \times w \frac{f_r}{N * z} \times \sqrt{d / D}$$

**The total mean tangential force is:**

$$P_{s \text{mean}(\text{total})} = Z_e \times K_s \times w \frac{f_r}{N * z} \times \sqrt{d / D}$$

**Where**

$Z_e$  = number of cutting teeth engaged in the same moment

$$Z_e = z \times \frac{\phi_e}{2\pi}$$

# Cutting forces and power in milling

After substituting the value of  $Z_e$  in total mean cutting force equation

$$P_{s(total)mean} = \frac{f_r \times d \times w}{\pi \times D \times N} \times K_s$$

# Cutting forces and power in milling

The mean machining power can be calculated as follows:

$$Power = P_{s(total)mean} \times V$$

$$Power = \frac{f_r \times d \times w}{\pi \times D \times N} \times K_s \times \pi \times D \times N$$

$$Power = f_r \times d \times w \times K_s$$

$$Power_{motor} = P_{smax} \times V \times \frac{1}{\eta_{mech}}$$

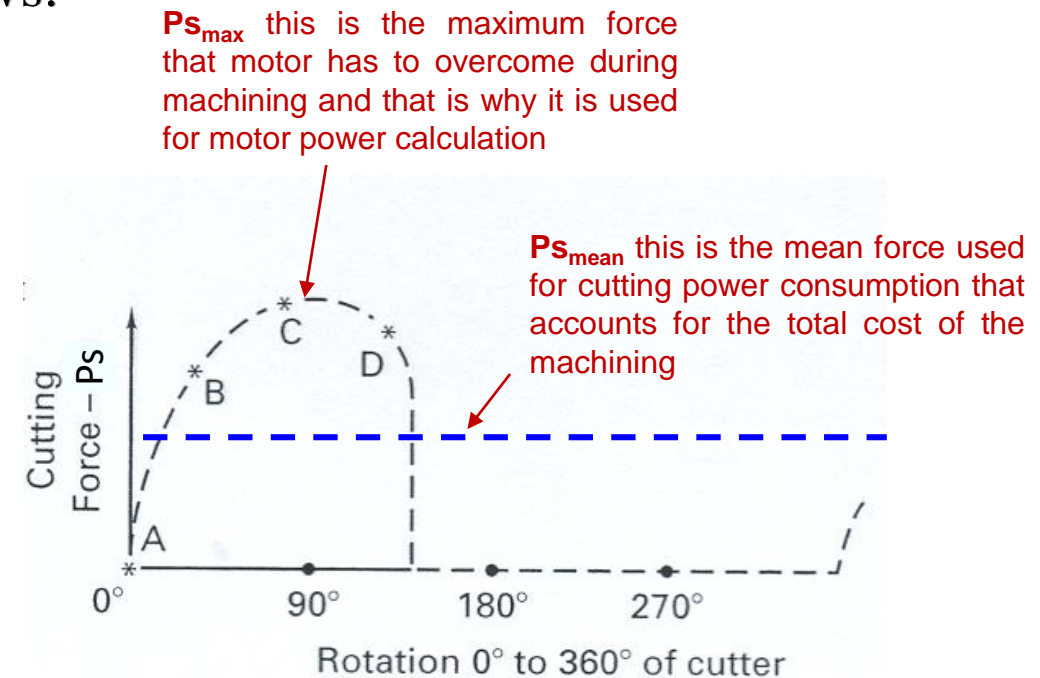

# Cutting forces and power in milling

The feed power is given by:

$$Power_{feed} = P_f \times f_r$$

# Machining time in peripheral milling

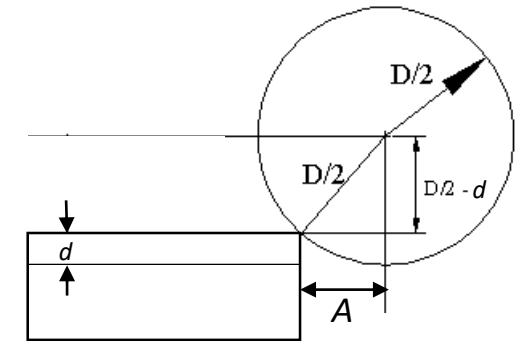
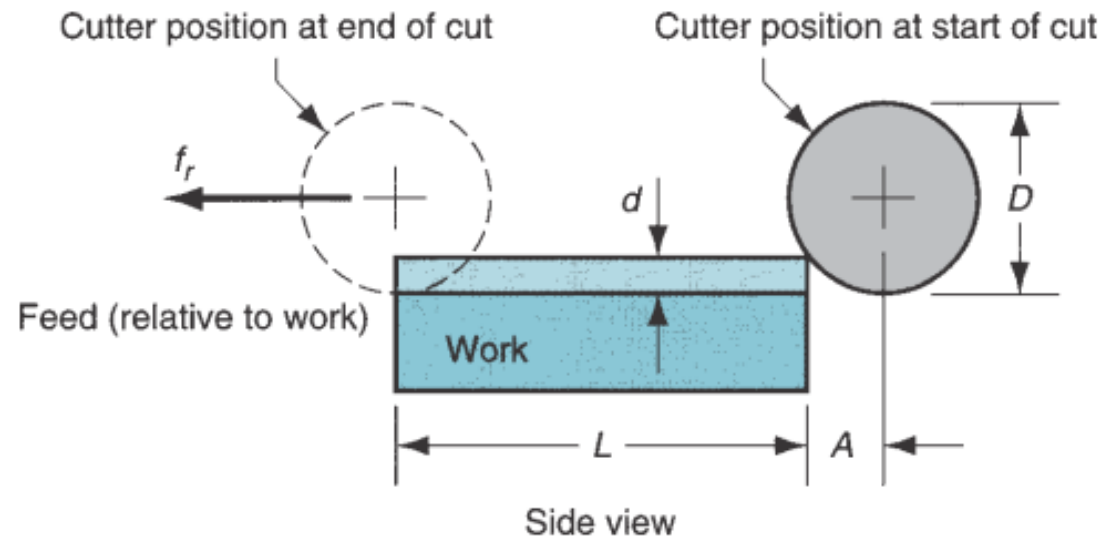

From figure, it can be noted,

$$A = \sqrt{d(D - d)}$$

$A$  = The approach distance to reach full cutter depth

$$T_m = \frac{L + A}{f_r}$$

$T_m$  = machining time

# Machining time in face milling

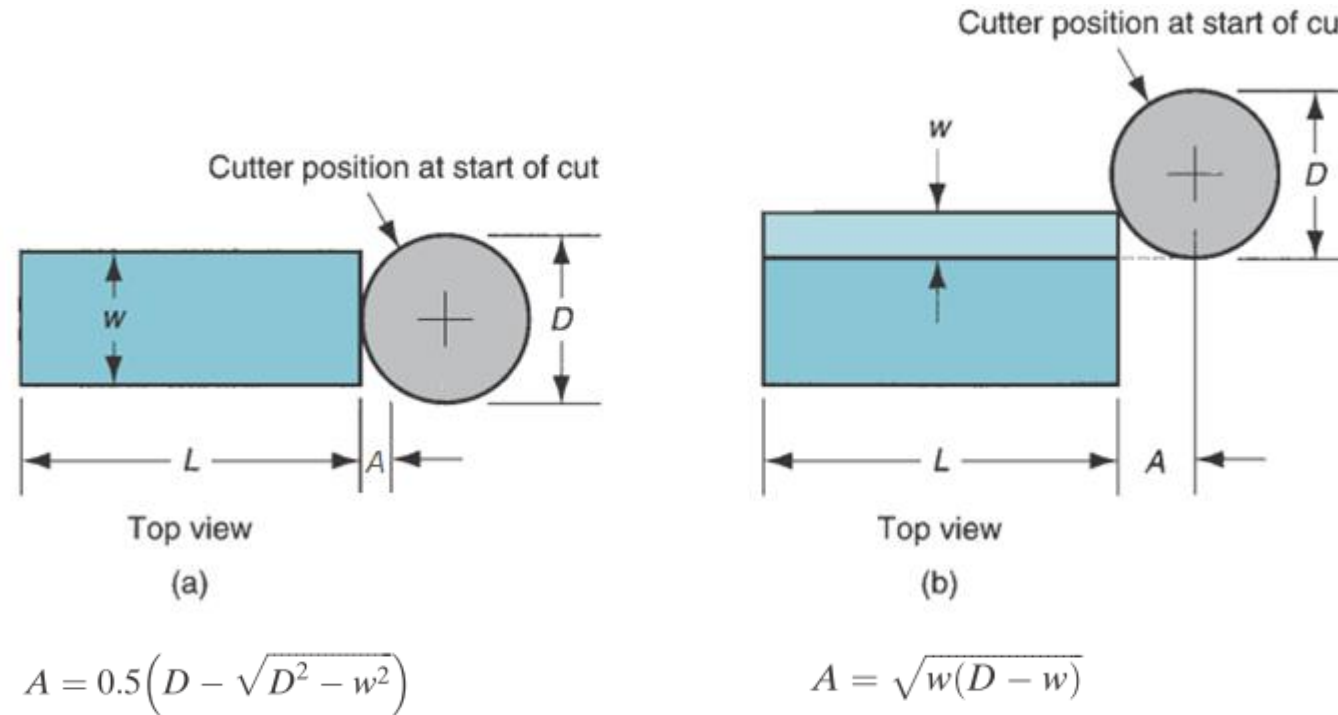

$$T_m = \frac{L + A}{f_r}$$

Face milling showing approach and over-travel distances for two cases: **(a)** when cutter is centered over the workpiece, and **(b)** when cutter is offset to one side over the work.

## Material removal rate

Material removal rate can be calculated as following:

$$MRR = \frac{L \times d \times w}{T_m}$$

**Where**

L = length of the cut

w = width of the cut

d = depth of the cut

T<sub>m</sub> = machining time