



CHAPTER 10

STRESSES IN SOIL MASS

Omitted Section 10.2 , 10.3 , 10.15 , 10.16

TYPES OF STRESSES IN SOIL

By: Kamal Tawfiq, Ph.D., P.E

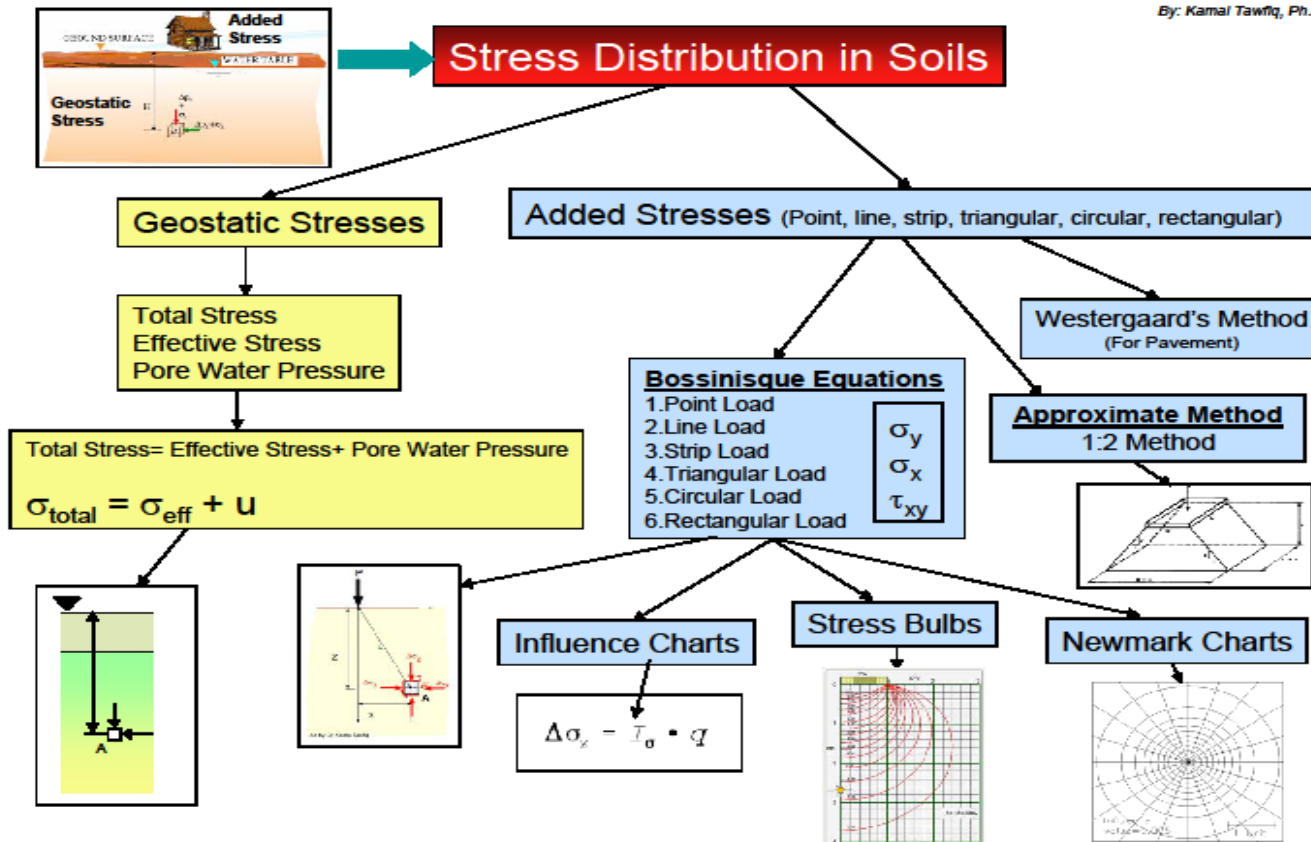

TYPES OF STRESSES IN SOIL

There are **two types** of stresses in soil.

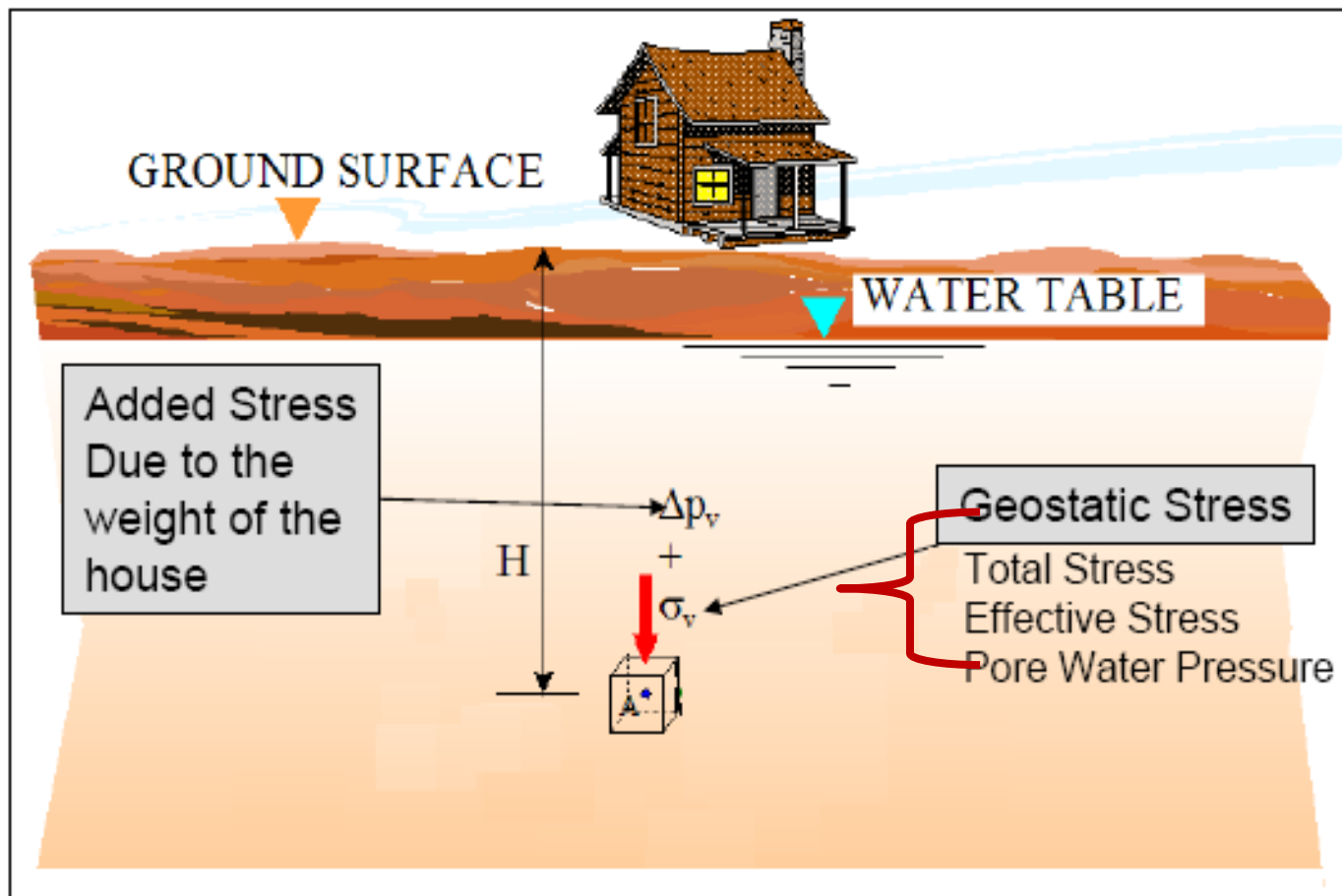

INTRODUCTION

- At a point within a soil mass, stress will be developed as a result of:
 - ✚ The soil laying above the point (overburden)
 - ✚ by a any structural or other loading imposed on that soil mass.
- In the preceding chapter we have discussed the stresses originated from weight of the soil itself. These stresses are called **BODY STRESSES** or **GEOSTATIC STRESSES**, or **OVERBURDEN**.

INTRODUCTION

○ Common examples of the external loads are as follows:

- ✚ Uniform **strip** loads such as the load on along wall footing of sufficient width.
- ✚ Uniformly loaded **square, rectangular or circular** footings such as column footings of buildings, pier footings, footings for water tanks, mats, etc
- ✚ **Triangular and or trapezoidal strip** loads such as the loads of long earth embankments.

INTRODUCTION

- Both **body stresses** and **induced stresses** must be taken into consideration in solving certain problems.
- The focus of this chapter is on the discussion of the principles of estimation of **vertical stress** increase in soil due to various types of loading, based on the **THEORY OF ELASTICITY**.
- We actually know that the soil **is not elastic**, however we use elasticity theory on the absence of better alternative. Estimation of induced vertical stress based on the assumption of elasticity yields **fairly good** results for practical work.

Stresses from Approximate Methods

2:1 Method

- ◉ In this method it is assumed that the STRESSED AREA is larger than the corresponding dimension of the loaded area by an amount equal to the **depth** of the subsurface area.

- ◉ Therefore, if a load is applied on a rectangular with dimension B and L , the stress on the soil at depth z is considered to be uniformly distributed on an area with dimension $(B+z)$ and $(L+z)$.

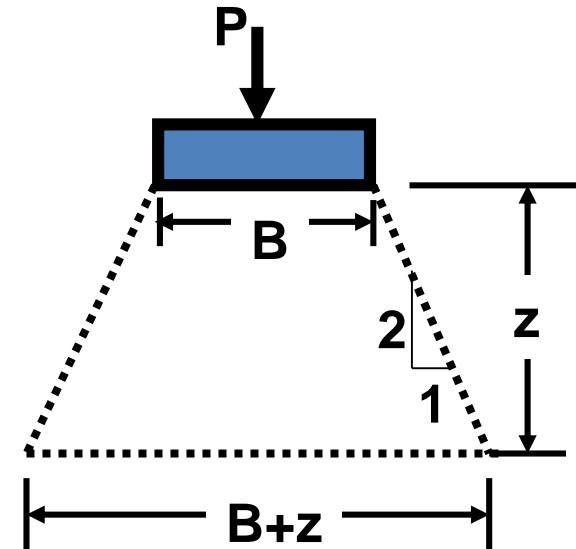

- ◉ This is called **2:1** method because the stressed area increases at a slope of **1** horizontally for each **2** of depth as measured from the depth of foundation.

Stresses from Approximate Methods

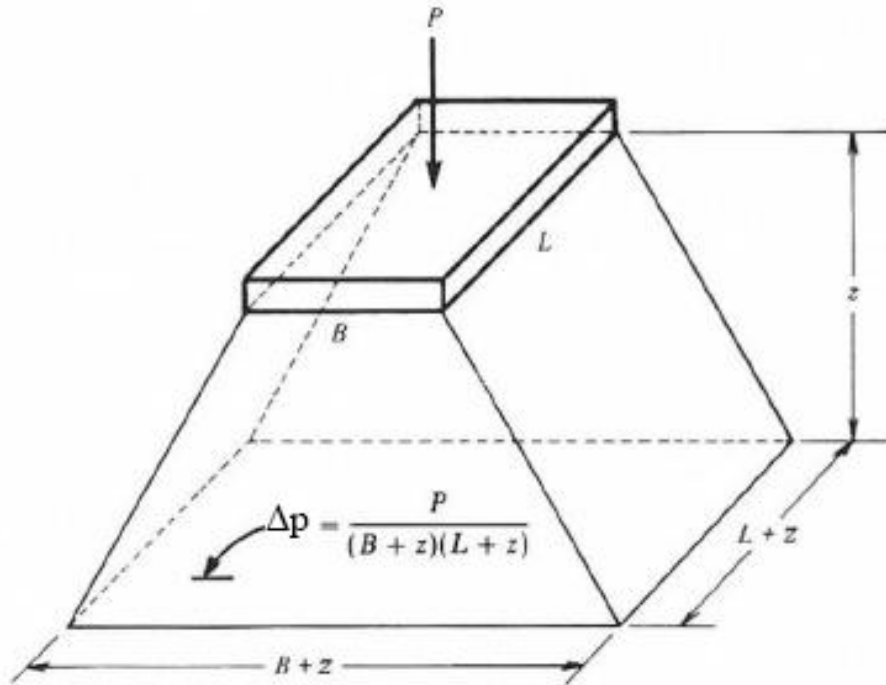

$$\sigma_z = \frac{P}{(B+z)(L+z)}$$

Stresses from Approximate Methods

- If the load at the surface is given to be **distributed**, it is first **converted** to **point** load by multiplying by the area ($B \times L$) as demonstrated in the figure below.

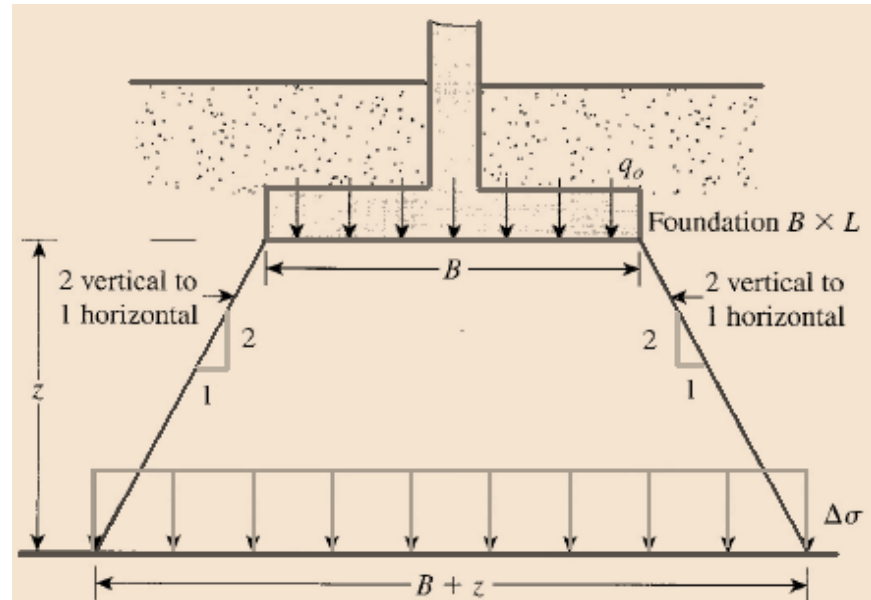

2:1 method of finding stress increase under a foundation

$$\Delta\sigma = \frac{q_o BL}{(B + z)(L + z)}$$

Stresses From Theory of Elasticity

- There are a number of solutions which are based on the theory of elasticity. Most of them assume the following assumptions:
 - ✚ The soil is homogeneous
 - ✚ The soil is isotropic
 - ✚ The soil is perfectly elastic infinite or semi-finite medium
- The derivations of the equations for various common loadings are **tedious**.
- We will concentrate only on **formula**, **tables** and **charts** for some of the loadings most **commonly** encountered in practice.
- **Tens of solutions** for different problems are now available in the literature. It is enough to say that a whole book (**Poulos and Davis**) is now available for the elastic solutions of various problems.

Stresses From Theory of Elasticity

ELASTIC SOLUTIONS FOR SOIL AND ROCK MECHANICS

by
H.G. Poulos
and
E.H. Davis

The book contains a comprehensive collection of graphs, tables and explicit solutions of problems in elasticity relevant to soil and rock mechanics.

Stresses From Theory of Elasticity

◉ The available solution depends on the following conditions:

1. Types of the applied load

- ✚ Point
- ✚ Distributed

2. Shape of the loaded area

- ✚ Rectangular
- ✚ Square
- ✚ Circular
- ✚ etc.

3. Extension of the Medium

- ✚ Half-space
- ✚ Finite
- ✚ layered

4. Type of soil

- ✚ Cohesive
- ✚ Cohesionless

5. Location of Load

- ✚ At the surface
- ✚ At a certain depth

6. Stiffness of Loaded Area

- ✚ Flexible
- ✚ Rigid

◉ We can see that **a lot of combinations** can be made from the above conditions. Next we will consider **some** of these solutions which are **well-known** and has been accepted and **extensively used**.

Stresses From Theory of Elasticity

Determination of vertical stress increase at a certain depth due to the application of load on the surface. The loading type includes:

- Point load
- Line load
- Uniformly distributed vertical strip load
- Linearly increasing vertical loading on a strip
- Embankment type of loading
- Uniformly loaded circular area
- Uniformly loaded rectangular area

Vertical Stresses Caused by a Point Load

- The most important original solution was given by **BOUSSINESQ (1885)** for the distribution of stress within a **linear elastic half space** resulting from a **point load normal** to the **surface** as shown

$$\Delta\sigma_z = \frac{3P}{2\pi} \frac{z^3}{L^5} = \frac{3P}{2\pi} \frac{z^3}{(r^2 + z^2)^{5/2}}$$

$$\Delta\sigma_z = \frac{P}{z^2} \left\{ \frac{3}{2\pi} \frac{1}{[(r/z)^2 + 1]^{5/2}} \right\} = \frac{P}{z^2} I_1$$

$$I_1 = \frac{3}{2\pi} \frac{1}{[(r/z)^2 + 1]^{5/2}}$$

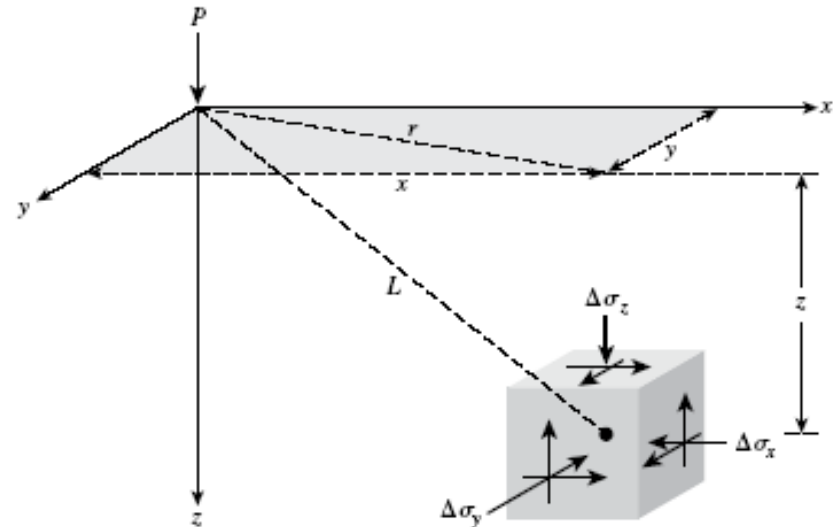

Vertical Stresses Caused by a Point Load

$$I_1 = \frac{3}{2\pi} \frac{1}{[(r/z)^2 + 1]^{5/2}}$$

Table 10.1 Variation of I_1 for Various Values of r/z [Eq. (10.14)]

r/z	I_1	r/z	I_1	r/z	I_1
0	0.4775	0.36	0.3521	1.80	0.0129
0.02	0.4770	0.38	0.3408	2.00	0.0085
0.04	0.4765	0.40	0.3294	2.20	0.0058
0.06	0.4723	0.45	0.3011	2.40	0.0040
0.08	0.4699	0.50	0.2733	2.60	0.0029
0.10	0.4657	0.55	0.2466	2.80	0.0021
0.12	0.4607	0.60	0.2214	3.00	0.0015
0.14	0.4548	0.65	0.1978	3.20	0.0011
0.16	0.4482	0.70	0.1762	3.40	0.00085
0.18	0.4409	0.75	0.1565	3.60	0.00066
0.20	0.4329	0.80	0.1386	3.80	0.00051
0.22	0.4242	0.85	0.1226	4.00	0.00040
0.24	0.4151	0.90	0.1083	4.20	0.00032
0.26	0.4050	0.95	0.0956	4.40	0.00026
0.28	0.3954	1.00	0.0844	4.60	0.00021
0.30	0.3849	1.20	0.0513	4.80	0.00017
0.32	0.3742	1.40	0.0317	5.00	0.00014
0.34	0.3632	1.60	0.0200		

EXAMPLE 10.3

Example 10.3

Consider a point load $P = 5$ kN (Figure 10.7). Calculate the vertical stress increase ($\Delta\sigma_z$) at $z = 0, 2$ m, 4 m, 6 m, 10 m, and 20 m. Given $x = 3$ m and $y = 4$ m.

Solution

$$r = \sqrt{x^2 + y^2} = \sqrt{3^2 + 4^2} = 5 \text{ m}$$

The following table can now be prepared.

r (m)	z (m)	$\frac{r}{z}$	I_1	$\Delta\sigma_z = \left(\frac{P}{z^2}\right)I_1$ (kN/m ²)
5	0	∞	0	0
	2	2.5	0.0034	0.0043
	4	1.25	0.0424	0.0133
	6	0.83	0.1295	0.0180
	10	0.5	0.2733	0.0137
	20	0.25	0.4103	0.0051

EXAMPLE 10.4

Example 10.4

Refer to Example 10.3. Calculate the vertical stress increase ($\Delta\sigma_z$) at $z = 2$ m; $y = 3$ m; and $x = 0, 1, 2, 3,$ and 4 m.

Solution

The following table can now be prepared. *Note:* $r = \sqrt{x^2 + y^2}$; $P = 5$ kN

x (m)	y (m)	r (m)	z (m)	$\frac{r}{z}$	I_1	$\Delta\sigma_z = \left(\frac{P}{z^2}\right)I_1$ (kN/m ²)
0	3	3	2	1.5	0.025	0.031
1	3	3.16	2	1.58	0.0208	0.026
2	3	3.61	2	1.81	0.0126	0.0158
3	3	4.24	2	2.1	0.007	0.009
4	3	5	2	2.5	0.0034	0.004

Vertical Stresses Caused by a Vertical Line Load

The value of $\Delta\sigma_z$ is the additional stress on soil caused by the line load. The value of $\Delta\sigma_z$ does not include the overburden pressure of the soil above point A.

$$\frac{\Delta\sigma_z}{(q/z)} = \frac{2}{\pi[(x/z)^2 + 1]^2}$$

Table 10.2 Variation of $\Delta\sigma_z/(q/z)$ with x/z [Eq. (10.16)]

x/z	$\Delta\sigma_z/(q/z)$	x/z	$\Delta\sigma_z/(q/z)$
0	0.637	1.3	0.088
0.1	0.624	1.4	0.073
0.2	0.589	1.5	0.060
0.3	0.536	1.6	0.050
0.4	0.473	1.7	0.042
0.5	0.407	1.8	0.035
0.6	0.344	1.9	0.030
0.7	0.287	2.0	0.025
0.8	0.237	2.2	0.019
0.9	0.194	2.4	0.014
1.0	0.159	2.6	0.011
1.1	0.130	2.8	0.008
1.2	0.107	3.0	0.006

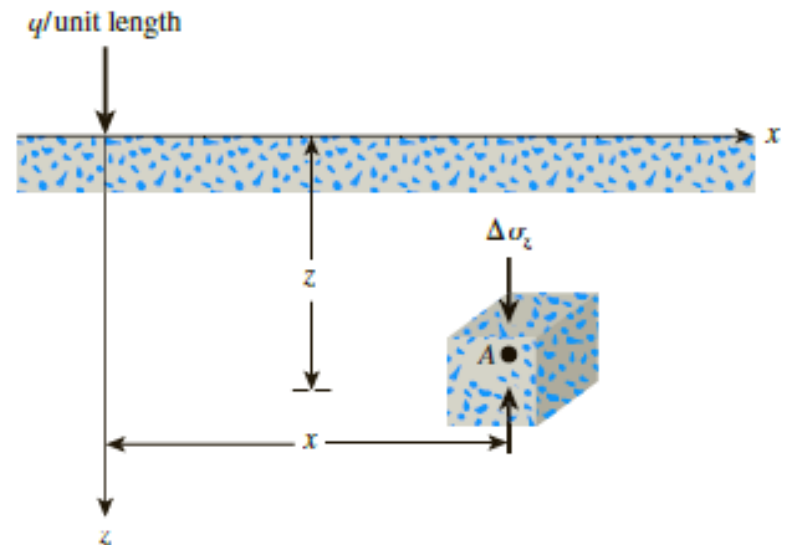

EXAMPLE 10.5

Example 10.5

Figure 10.9a shows two line loads on the ground surface. Determine the increase of stress at point A.

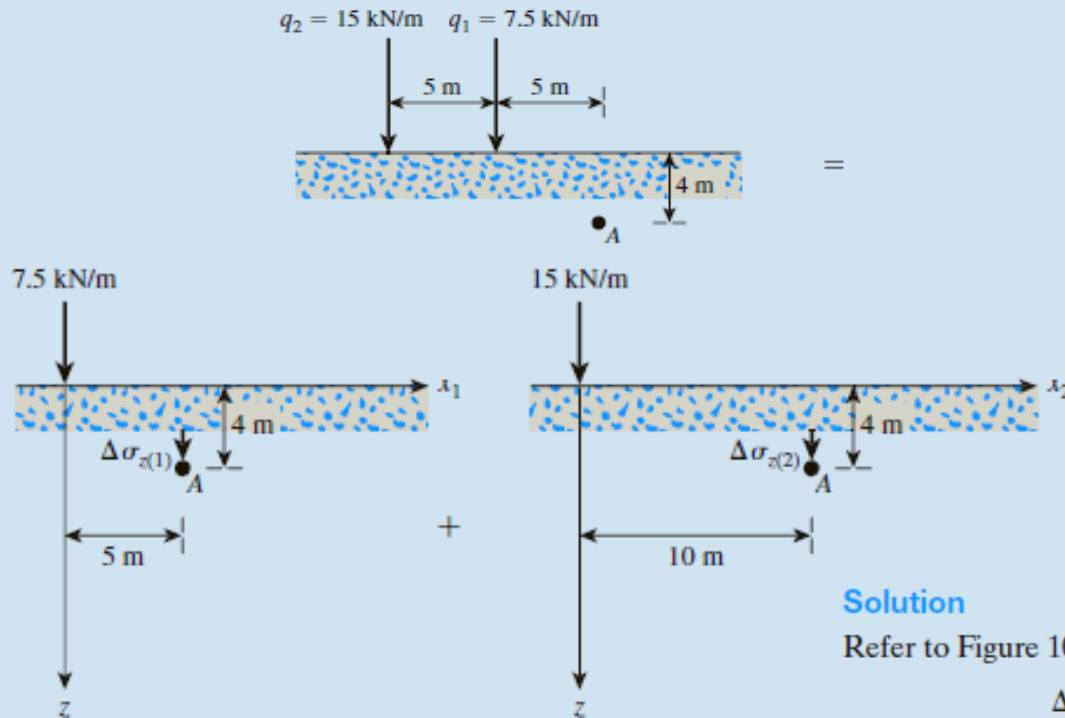

Solve using Table 10.2

Solution

Refer to Figure 10.9b. The total stress at A is

$$\Delta\sigma_z = \Delta\sigma_{z(1)} + \Delta\sigma_{z(2)}$$

$$\Delta\sigma_{z(1)} = \frac{2q_1z^3}{\pi(x_1^2 + z^2)^2} = \frac{(2)(7.5)(4)^3}{\pi(5^2 + 4^2)^2} = 0.182 \text{ kN/m}^2$$

$$\Delta\sigma_{z(2)} = \frac{2q_2z^3}{\pi(x_2^2 + z^2)^2} = \frac{(2)(15)(4)^3}{\pi(10^2 + 4^2)^2} = 0.045 \text{ kN/m}^2$$

$$\Delta\sigma_z = 0.182 + 0.045 = 0.227 \text{ kN/m}^2$$

Vertical Stresses Caused by a Horizontal Line Load

$$\Delta\sigma_z = \frac{2q}{\pi} \frac{xz^2}{(x^2 + z^2)^2}$$

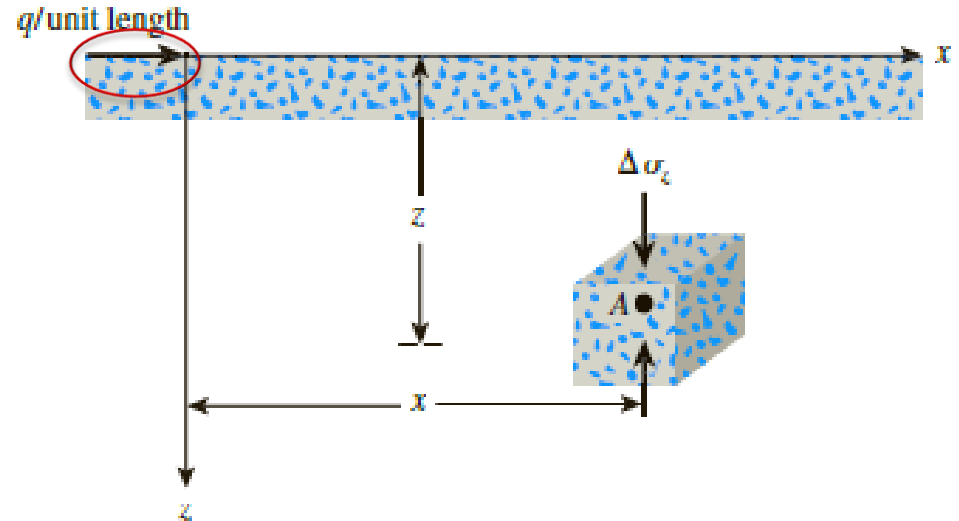

Table 10.3 Variation of $\Delta\sigma_z/(q/z)$ with x/z

x/z	$\Delta\sigma_z/(q/z)$	x/z	$\Delta\sigma_z/(q/z)$
0	0	0.7	0.201
0.1	0.062	0.8	0.189
0.2	0.118	0.9	0.175
0.3	0.161	1.0	0.159
0.4	0.189	1.5	0.090
0.5	0.204	2.0	0.051
0.6	0.207	3.0	0.019

EXAMPLE 10.6

Example 10.6

An inclined line load with a magnitude of 10 kN/m is shown in Figure 10.11. Determine the increase of vertical stress $\Delta\sigma_z$ at point A due to the line load.

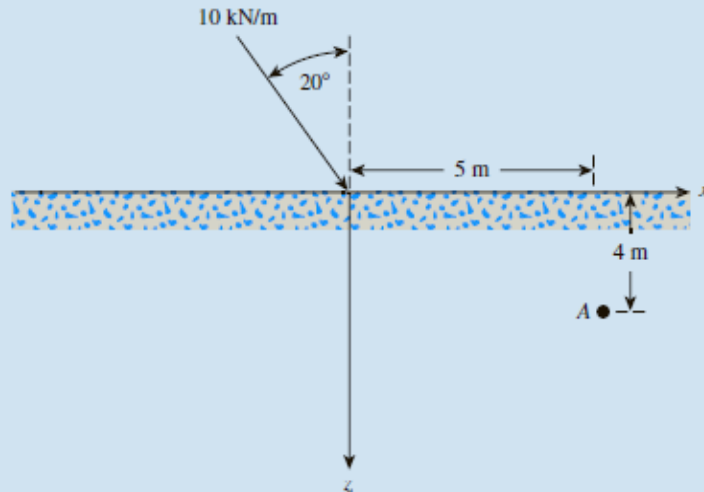

Solution

The vertical component of the inclined load $q_V = 10 \cos 20 = 9.4$ kN/m, and the horizontal component $q_H = 10 \sin 20 = 3.42$ kN/m. For point A, $x/z = 5/4 = 1.25$. Using Table 10.2, the vertical stress increase at point A due to q_V is

$$\frac{\Delta\sigma_{z(V)}}{\left(\frac{q_V}{z}\right)} = 0.098$$
$$\Delta\sigma_{z(V)} = (0.098)\left(\frac{q_V}{z}\right) = (0.098)\left(\frac{9.4}{4}\right) = 0.23 \text{ kN/m}^2$$

Similarly, using Table 10.3, the vertical stress increase at point A due to q_H is

$$\frac{\Delta\sigma_{z(H)}}{\left(\frac{q_H}{z}\right)} = 0.125$$
$$\Delta\sigma_{z(H)} = (0.125)\left(\frac{3.42}{4}\right) = 0.107 \text{ kN/m}^2$$

Thus, the total is

$$\Delta\sigma_z = \Delta\sigma_{z(V)} + \Delta\sigma_{z(H)} = 0.23 + 0.107 = 0.337 \text{ kN/m}^2$$

Solve by Equations

Vertical Stress Caused by a Vertical Strip Load (Finite width and infinite length)

Such conditions are found for structures extended very much in one direction, such as **strip** and **wall** foundations, **foundations** of **retaining walls**, embankments, dams and the like.

$$\Delta\sigma_z = \frac{q}{\pi} \left\{ \tan^{-1} \left[\frac{z}{x - (B/2)} \right] - \tan^{-1} \left[\frac{z}{x + (B/2)} \right] \right. \\ \left. \frac{Bz[x^2 - z^2 - (B^2/4)]}{[x^2 + z^2 - (B^2/4)]^2 + B^2z^2} \right\}$$

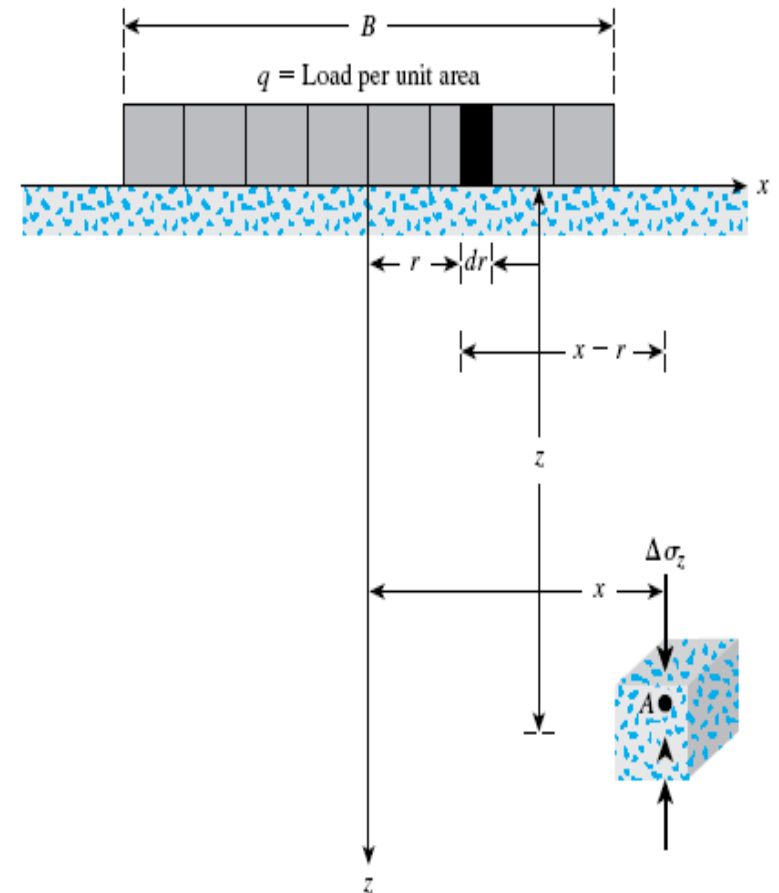

Vertical Stress Caused by a Vertical Strip Load (Finite width and infinite length)

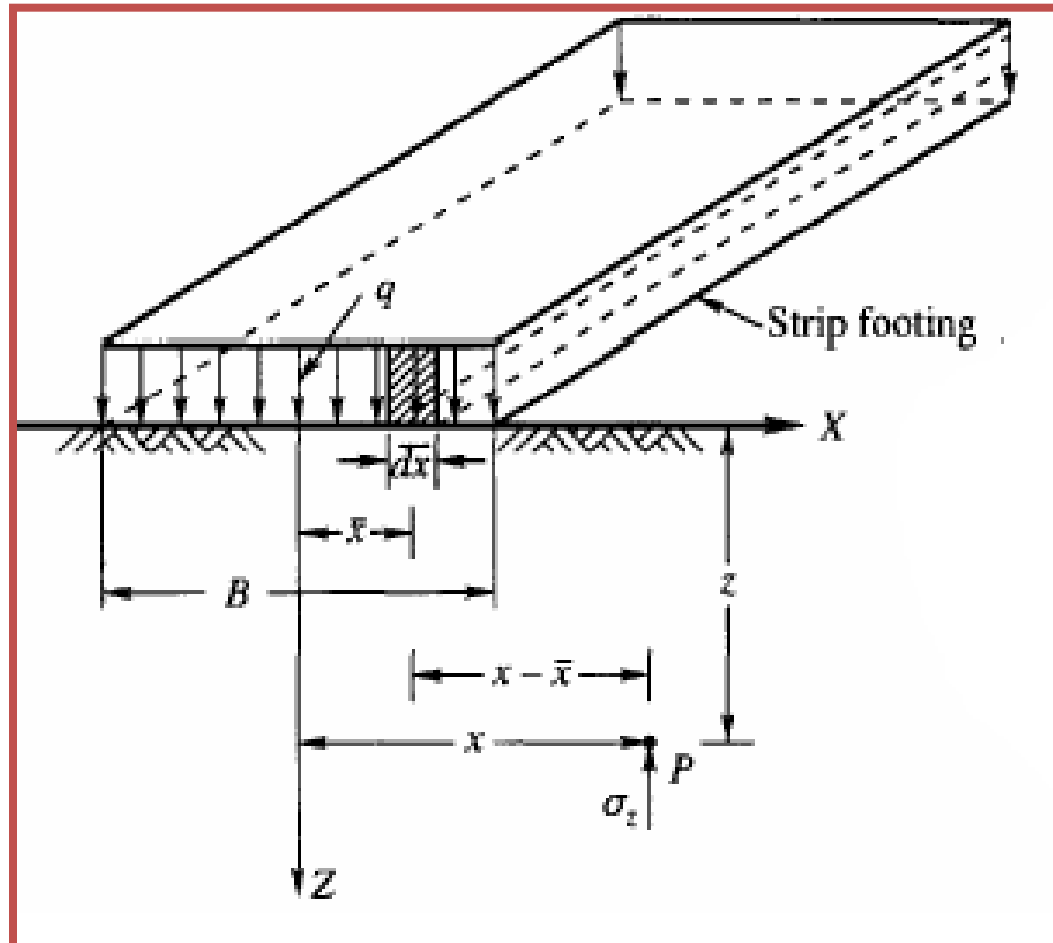

Vertical Stress Caused by a Vertical Strip Load (Finite width and infinite length)

$$\begin{aligned}\Delta\sigma_z &= \int d\sigma_z = \int_{-B/2}^{+B/2} \left(\frac{2q}{\pi}\right) \left\{ \frac{z^3}{[(x-r)^2 + z^2]^2} \right\} dr \\ &= \frac{q}{\pi} \left\{ \tan^{-1} \left[\frac{z}{x - (B/2)} \right] - \tan^{-1} \left[\frac{z}{x + (B/2)} \right] \right. \\ &\quad \left. - \frac{Bz[x^2 - z^2 - (B^2/4)]}{[x^2 + z^2 - (B^2/4)]^2 + B^2z^2} \right\} \quad (10.19)\end{aligned}$$

With respect to Eq. (10.19), the following should be kept in mind:

1. $\tan^{-1} \left[\frac{z}{x - \left(\frac{B}{2}\right)} \right]$ and $\tan^{-1} \left[\frac{z}{x + \left(\frac{B}{2}\right)} \right]$ are in radians.
2. The magnitude of $\Delta\sigma_z$ is the same value of x/z (\pm).
3. Equation (10.19) is valid as shown in Figure 10.12; that is, for point A, $x \geq B/2$.

However, for $x = 0$ to $x < B/2$, the magnitude of $\tan^{-1} \left[\frac{z}{x - \left(\frac{B}{2}\right)} \right]$ becomes

negative. For this case, that should be replaced by $\pi + \tan^{-1} \left[\frac{z}{x - \left(\frac{B}{2}\right)} \right]$.

Vertical Stress Caused by a Vertical Strip Load (Finite width and infinite length)

Table 10.4 Variation of $\Delta\sigma_z/q$ with $2z/B$ and $2x/B$ [Eq. (10.19)]

$2z/B$	$2x/B$											
	0.0	0.1	0.2	0.3	0.4	0.5	0.6	0.7	0.8	0.9	1.0	
0.00	1.000	1.000	1.000	1.000	1.000	1.000	1.000	1.000	1.000	1.000	1.000	0.000
0.10	1.000	1.000	0.999	0.999	0.999	0.998	0.997	0.993	0.980	0.909	0.500	
0.20	0.997	0.997	0.996	0.995	0.992	0.988	0.979	0.959	0.909	0.775	0.500	
0.30	0.990	0.989	0.987	0.984	0.978	0.967	0.947	0.908	0.833	0.697	0.499	
0.40	0.977	0.976	0.973	0.966	0.955	0.937	0.906	0.855	0.773	0.651	0.498	
0.50	0.959	0.958	0.953	0.943	0.927	0.902	0.864	0.808	0.727	0.620	0.497	
0.60	0.937	0.935	0.928	0.915	0.896	0.866	0.825	0.767	0.691	0.598	0.495	
0.70	0.910	0.908	0.899	0.885	0.863	0.831	0.788	0.732	0.662	0.581	0.492	
0.80	0.881	0.878	0.869	0.853	0.829	0.797	0.755	0.701	0.638	0.566	0.489	
0.90	0.850	0.847	0.837	0.821	0.797	0.765	0.724	0.675	0.617	0.552	0.485	
1.00	0.818	0.815	0.805	0.789	0.766	0.735	0.696	0.650	0.598	0.540	0.480	
1.10	0.787	0.783	0.774	0.758	0.735	0.706	0.670	0.628	0.580	0.529	0.474	
1.20	0.755	0.752	0.743	0.728	0.707	0.679	0.646	0.607	0.564	0.517	0.468	
1.30	0.725	0.722	0.714	0.699	0.679	0.654	0.623	0.588	0.548	0.506	0.462	
1.40	0.696	0.693	0.685	0.672	0.653	0.630	0.602	0.569	0.534	0.495	0.455	
1.50	0.668	0.666	0.658	0.646	0.629	0.607	0.581	0.552	0.519	0.484	0.448	
1.60	0.642	0.639	0.633	0.621	0.605	0.586	0.562	0.535	0.506	0.474	0.440	
1.70	0.617	0.615	0.608	0.598	0.583	0.565	0.544	0.519	0.492	0.463	0.433	
1.80	0.593	0.591	0.585	0.576	0.563	0.546	0.526	0.504	0.479	0.453	0.425	
1.90	0.571	0.569	0.564	0.555	0.543	0.528	0.510	0.489	0.467	0.443	0.417	
2.00	0.550	0.548	0.543	0.535	0.524	0.510	0.494	0.475	0.455	0.433	0.409	
2.10	0.530	0.529	0.524	0.517	0.507	0.494	0.479	0.462	0.443	0.423	0.401	
2.20	0.511	0.510	0.506	0.499	0.490	0.479	0.465	0.449	0.432	0.413	0.393	
2.30	0.494	0.493	0.489	0.483	0.474	0.464	0.451	0.437	0.421	0.404	0.385	
2.40	0.477	0.476	0.473	0.467	0.460	0.450	0.438	0.425	0.410	0.395	0.378	
2.50	0.462	0.461	0.458	0.452	0.445	0.436	0.426	0.414	0.400	0.386	0.370	
2.60	0.447	0.446	0.443	0.439	0.432	0.424	0.414	0.403	0.390	0.377	0.363	
2.70	0.433	0.432	0.430	0.425	0.419	0.412	0.403	0.393	0.381	0.369	0.355	
2.80	0.420	0.419	0.417	0.413	0.407	0.400	0.392	0.383	0.372	0.360	0.348	
2.90	0.408	0.407	0.405	0.401	0.396	0.389	0.382	0.373	0.363	0.352	0.341	
3.00	0.396	0.395	0.393	0.390	0.385	0.379	0.372	0.364	0.355	0.345	0.334	

Vertical Stress Caused by a Vertical Strip Load (Finite width and infinite length)

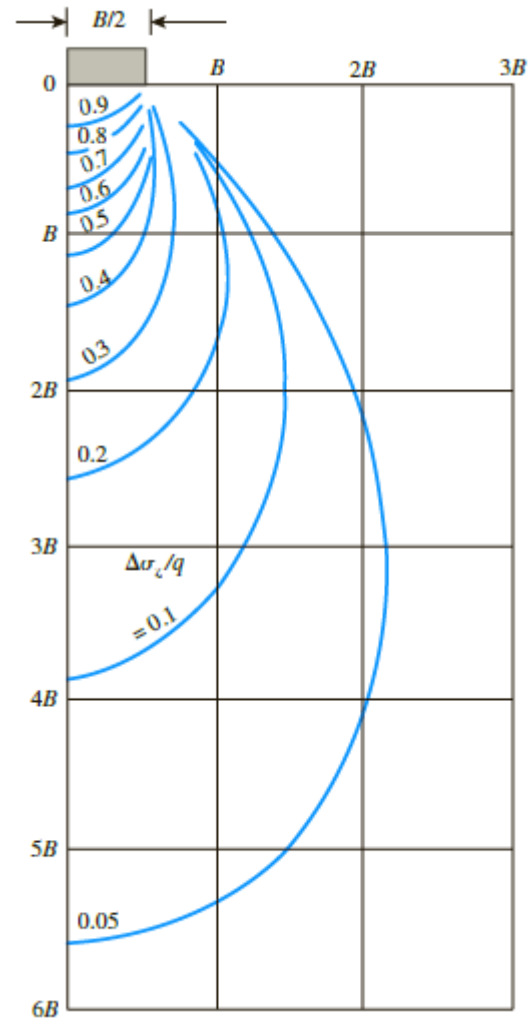

EXAMPLE 10.7

Example 10.7

Refer to Figure 10.12. Given: $B = 4$ m and $q = 100$ kN/m². For point A, $z = 1$ m and $x = 1$ m. Determine the vertical stress $\Delta\sigma_z$ at A. Use Eq. (10.19).

Solution

Since $x = 1$ m $<$ $B/2 = 2$ m,

$$\Delta\sigma_z = \frac{q}{\pi} \left\{ \tan^{-1} \left[\frac{z}{x - \left(\frac{B}{2}\right)} \right] + \pi - \tan^{-1} \left[\frac{z}{x + \left(\frac{B}{2}\right)} \right] \right.$$

$$\left. - \frac{Bz \left[x^2 - z^2 - \left(\frac{B^2}{4}\right) \right]}{\left[x^2 + z^2 - \left(\frac{B^2}{4}\right) \right]^2 + B^2 z^2} \right\}$$

$$\tan^{-1} \left[\frac{z}{x - \left(\frac{B}{2}\right)} \right] = \tan^{-1} \left(\frac{1}{1 - 2} \right) = -45^\circ = -0.785 \text{ rad}$$

$$\tan^{-1} \left[\frac{z}{x + \left(\frac{B}{2}\right)} \right] = \tan^{-1} \left(\frac{1}{1 + 2} \right) = 18.43^\circ = 0.322 \text{ rad}$$

$$\frac{Bz \left[x^2 - z^2 - \left(\frac{B^2}{4}\right) \right]}{\left[x^2 + z^2 - \left(\frac{B^2}{4}\right) \right]^2 + B^2 z^2} = \frac{(4)(1) \left[(1)^2 - (1)^2 - \left(\frac{16}{4}\right) \right]}{\left[(1)^2 + (1)^2 - \left(\frac{16}{4}\right) \right]^2 + (16)(1)} = -0.8$$

Hence,

$$\frac{\Delta\sigma_z}{q} = \frac{1}{\pi} [-0.785 + \pi - 0.322 - (-0.8)] = 0.902$$

EXAMPLE 10.7

Now, compare with Table 10.4. For this case, $\frac{2x}{B} = \frac{(2)(1)}{4} = 0.5$ and $\frac{2z}{B} = \frac{(2)(1)}{4} = 0.5$.

So, $\frac{\Delta\sigma_z}{q} = 0.902$ (Check)

$$\Delta\sigma_z = 0.902q = (0.902)(100) = 90.2 \text{ kN/m}^2$$

Vertical Stress Caused by a Horizontal Strip Load

$$\Delta\sigma_z = \frac{4bqxz^2}{\pi[(x^2 + z^2 - b^2)^2 + 4b^2z^2]}$$

Table 10.5 Variation of $\Delta\sigma_z/q$ with z/b and x/b [Eq. (10.20)]

z/b	x/b					
	0	0.5	1.0	1.5	2.0	2.5
0	—	—	—	—	—	—
0.25	—	0.052	0.313	0.061	0.616	—
0.5	—	0.127	0.300	0.147	0.055	0.025
1.0	—	0.159	0.255	0.210	0.131	0.074
1.5	—	0.128	0.204	0.202	0.157	0.110
2.0	—	0.096	0.159	0.175	0.157	0.126
2.5	—	0.072	0.124	0.147	0.144	0.127

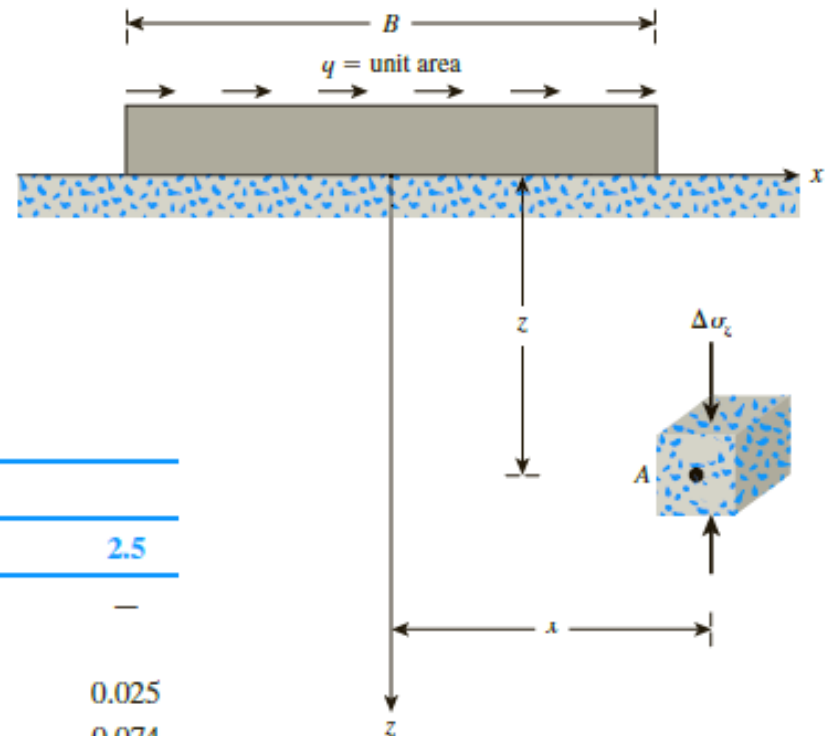

EXAMPLE 10.8

Example 10.8

Refer to Figure 10.14. Given: $B = 4$ m, $z = 1$ m, and $q = 100$ kN/m². Determine $\Delta\sigma_z$ at points ± 1 m.

Solution

From Eq. (10.20),

$$\begin{aligned}\frac{\Delta\sigma_z}{q} &= \frac{4bxz^2}{\pi[(x^2 + z^2 - b^2)^2 + 4b^2z^2]} \\ &= \frac{(4)\left(\frac{4}{2}\right)(\pm 1)(1)^2}{\pi\{[(\pm 1)^2 + (1)^2 - (2)^2]^2 + (4)(2)^2(1)^2\}} \\ &= \frac{\pm 8}{\pi[(4) + (16)]} = \pm 0.127\end{aligned}$$

Note: Compare this value of $\Delta\sigma_z/q = 0.127$ for $z/b = 1/2 = 0.5$ and $x/b = 1/2 = 0.5$ in Table 10.5. So,

$$\Delta\sigma_z = (0.127)(100) = 12.7 \text{ kN/m}^2 \text{ at } x = +1 \text{ m}$$

and

$$\Delta\sigma_z = (-0.127)(100) = -12.7 \text{ kN/m}^2 \text{ at } x = -1 \text{ m}$$

EXAMPLE 10.9

Example 10.9

Consider the inclined strip load shown in Figure 10.15. Determine the vertical stress $\Delta\sigma_z$ at A ($x = 2.25$ m, $z = 3$ m) and B ($x = -2.25$ m, $z = 3$ m). Given: width of the strip = 3 m.

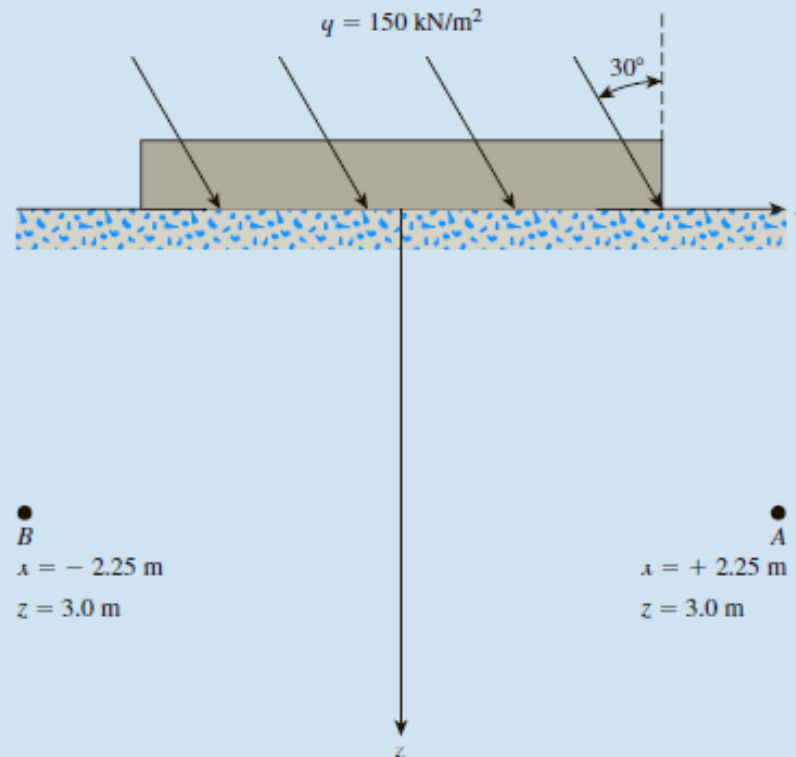

Figure 10.15

EXAMPLE 10.9

Solution

Vertical component of $q = q_v = q \cos 30 = 150 \cos 30 = 129.9 \text{ kN/m}^2$

Horizontal component of $q = q_h = q \sin 30 = 150 \sin 30 = 75 \text{ kN/m}^2$

$\Delta\sigma_z$ due to q_v :

$$\frac{2z}{B} = \frac{(2)(3)}{3} = 2$$

$$\frac{2x}{B} = \frac{(2)(\pm 2.25)}{3} = \pm 1.5$$

From Table 10.4, $\Delta\sigma_z/q_v = 0.288$.

$$\Delta\sigma_{z(v)} = (0.288)(129.9) = 37.4 \text{ kN/m}^2 \text{ (at } A \text{ and at } B\text{)}$$

$\Delta\sigma_z$ due to q_h :

$$b = \frac{B}{2} = \frac{3}{2} = 1.5$$

$$\frac{z}{b} = \frac{3}{1.5} = 2$$

$$\frac{x}{b} = \frac{\pm 2.25}{1.5} = \pm 1.5$$

From Table 10.5, $\Delta\sigma_z/q_h = \pm 0.175$. So at A ,

$$\Delta\sigma_z = (+0.175)q_h = (0.175)(75) = 13.13 \text{ kN/m}^2$$

and at B ,

$$\Delta\sigma_z = (-0.175)q_h = (-0.175)(75) = -13.13 \text{ kN/m}^2$$

Hence, at A ,

$$\Delta\sigma_z = \Delta\sigma_{z(v)} + \Delta\sigma_{z(h)} = 37.4 + 13.13 = 50.53 \text{ kN/m}^2$$

At B ,

$$\Delta\sigma_z = \Delta\sigma_{z(v)} + \Delta\sigma_{z(h)} = 37.4 + (-13.13) = 24.27 \text{ kN/m}^2$$

Linearly Increasing Vertical Loading on an Infinite Strip

$$\Delta\sigma_z = \frac{q}{2\pi} \left(\frac{2x}{B} \alpha - \sin 2\delta \right)$$

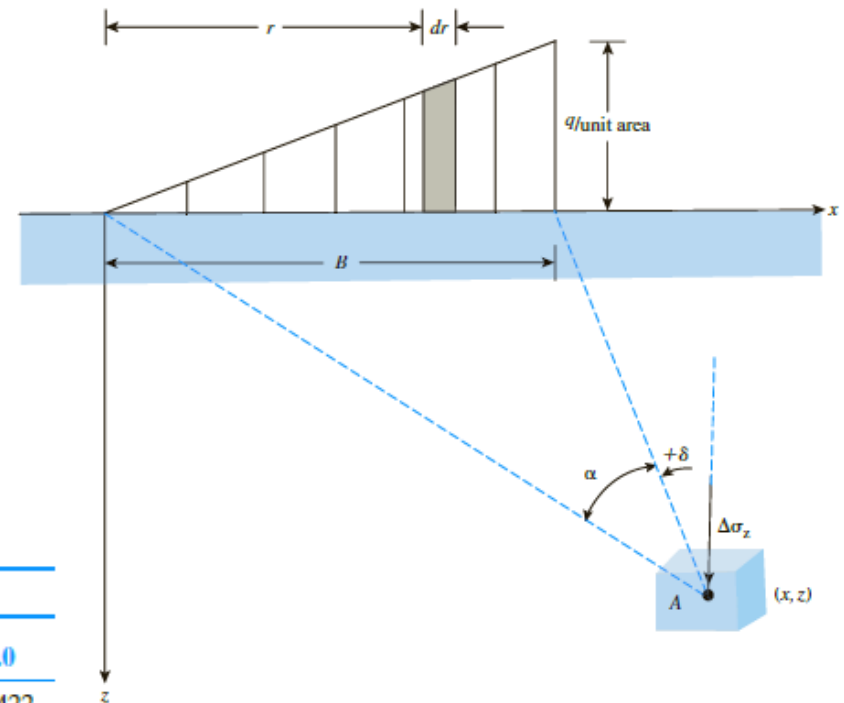

Table 10.6 Variation of $\Delta\sigma_z/q$ with $2x/B$ and $2z/B$ [Eq. (10.21)]

$\frac{2x}{B}$	$\frac{2z}{B}$								
	0	0.5	1.0	1.5	2.0	2.5	3.0	4.0	5.0
-3	0	0.0003	0.0018	0.00054	0.0107	0.0170	0.0235	0.0347	0.0422
-2	0	0.0008	0.0053	0.0140	0.0249	0.0356	0.0448	0.0567	0.0616
-1	0	0.0041	0.0217	0.0447	0.0643	0.0777	0.0854	0.0894	0.0858
0	0	0.0748	0.1273	0.1528	0.1592	0.1553	0.1469	0.1273	0.1098
1	0.5	0.4797	0.4092	0.3341	0.2749	0.2309	0.1979	0.1735	0.1241
2	0.5	0.4220	0.3524	0.2952	0.2500	0.2148	0.1872	0.1476	0.1211
3	0	0.0152	0.0622	0.1010	0.1206	0.1268	0.1258	0.1154	0.1026
4	0	0.0019	0.0119	0.0285	0.0457	0.0596	0.0691	0.0775	0.0776
5	0	0.0005	0.0035	0.0097	0.0182	0.0274	0.0358	0.0482	0.0546

EXAMPLE 10.10

Example 10.10

Refer to Figure 10.17. For a linearly increasing vertical loading on an infinite strip, given: $B = 2$ m; $q = 100$ kN/m². Determine the vertical stress $\Delta\sigma_z$ at A (-1 m, 1.5 m).

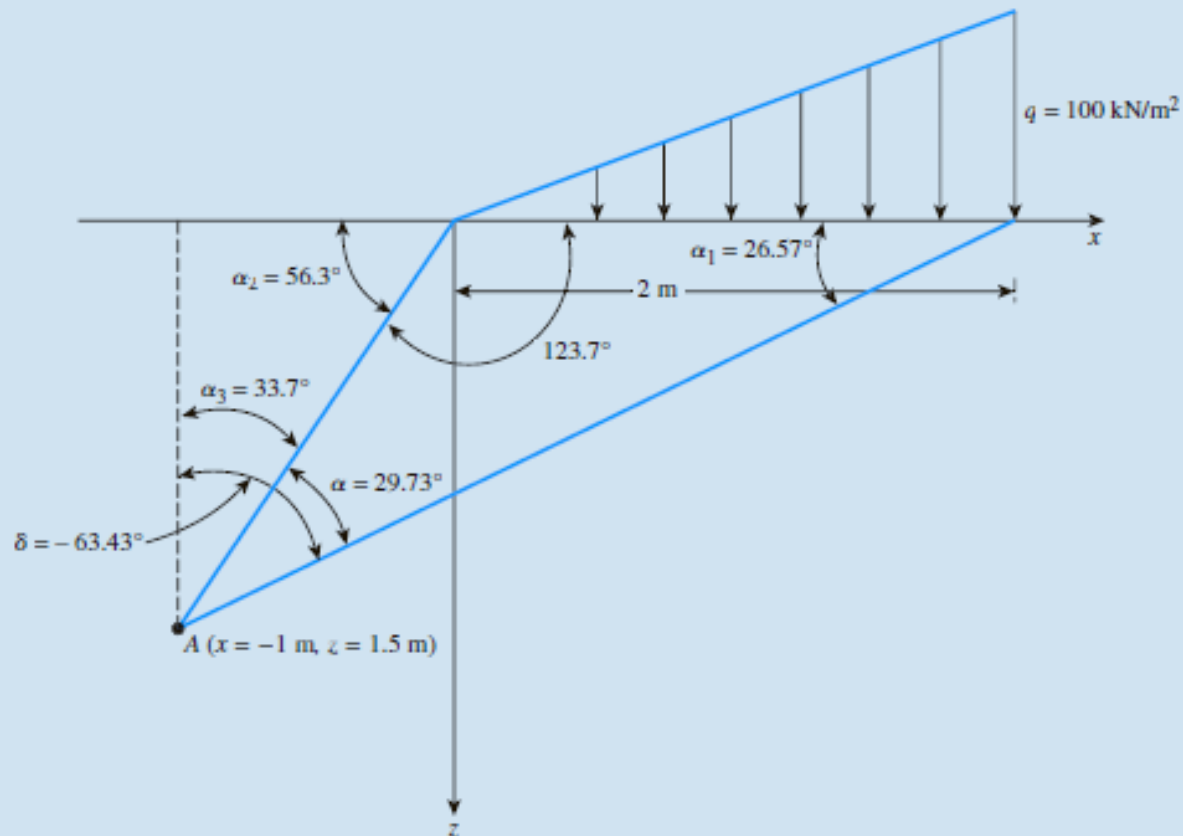

EXAMPLE 10.10

Solution

Referring to Figure 10.17,

$$\alpha_1 = \tan^{-1}\left(\frac{1.5}{3}\right) = 26.57^\circ$$

$$\alpha_2 = \tan^{-1}\left(\frac{1.5}{1}\right) = 56.3^\circ$$

$$\alpha = \alpha_2 - \alpha_1 = 56.3 - 26.57 = 29.73^\circ$$

$$\alpha_3 = 90 - \alpha_2 = 90 - 56.3 = 33.7^\circ$$

$$\delta = -(\alpha_3 + \alpha) = -(33.7 + 29.73) = -63.43^\circ$$

$$2\delta = -126.86^\circ$$

From Eq. (10.21),

$$\begin{aligned} \frac{\Delta\sigma_z}{q} &= \frac{1}{2\pi} \left(\frac{2x}{B} \alpha - \sin 2\delta \right) = \frac{1}{2\pi} \left[\frac{2 \times (-1)}{2} \left(\frac{\pi}{180} \times 29.73 \right) \right. \\ &\quad \left. - \sin(-126.86) \right] \\ &= \frac{1}{2\pi} [-0.519 - (-0.8)] = 0.0447 \end{aligned}$$

Compare this value of $\frac{\Delta\sigma_z}{q}$ with

$$\frac{2x}{B} = \frac{(2)(-1)}{2} = -1 \text{ and } \frac{2z}{B} = \frac{(2)(1.5)}{2} = 1.5 \text{ given in Table 10.6. It matches, so}$$

$$\Delta\sigma_z = (0.0447)(q) = (0.0447)(100) = 4.47 \text{ kN/m}^2$$

Vertical Stress Due to Embankment Loading

$$\Delta\sigma_z = \frac{q_o}{\pi} \left[\left(\frac{B_1 + B_2}{B_2} \right) (\alpha_1 + \alpha_2) - \frac{B_1}{B_2} (\alpha_2) \right]$$

$$\alpha_1 \text{ (radians)} = \tan^{-1} \left(\frac{B_1 + B_2}{z} \right) - \tan^{-1} \left(\frac{B_1}{z} \right)$$

$$\alpha_2 = \tan^{-1} \left(\frac{B_1}{z} \right)$$

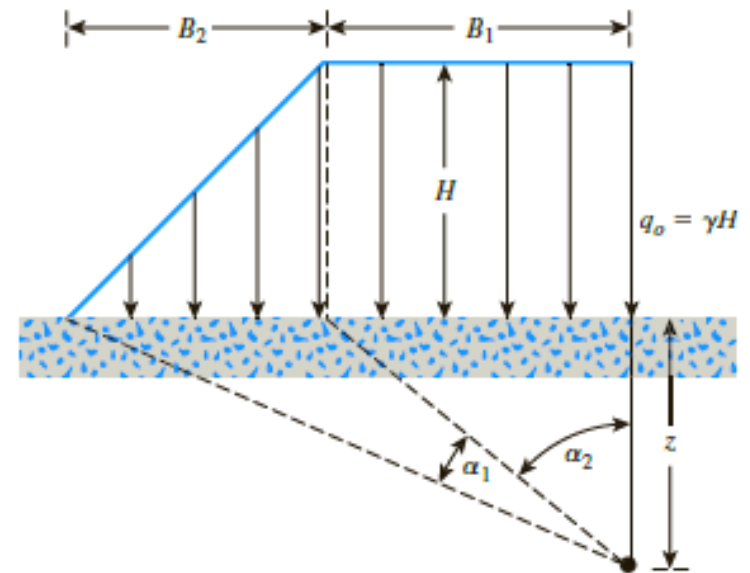

EXAMPLE 10.11

Example 10.11

An embankment is shown in Figure 10.20a. Determine the stress increase under the embankment at points A_1 and A_2 .

Solution

$$\gamma H = (17.5)(7) = 122.5 \text{ kN/m}^2$$

Stress Increase at A_1

The left side of Figure 10.20b indicates that $B_1 = 2.5 \text{ m}$ and $B_2 = 14 \text{ m}$. So,

$$\frac{B_1}{z} = \frac{2.5}{5} = 0.5; \frac{B_2}{z} = \frac{14}{5} = 2.8$$

According to Figure 10.19, in this case, $I_2 = 0.445$. Because the two sides in Figure 10.20b are symmetrical, the value of I_2 for the right side will also be 0.445. So,

$$\begin{aligned} \Delta\sigma_z &= \Delta\sigma_{z(1)} + \Delta\sigma_{z(2)} = q_o [I_{2(\text{Left})} + I_{2(\text{Right})}] \\ &= 122.5 [0.445 + 0.445] = \mathbf{109.03 \text{ kN/m}^2} \end{aligned}$$

Stress Increase at A_2

Refer to Figure 10.20c. For the left side, $B_2 = 5 \text{ m}$ and $B_1 = 0$. So,

$$\frac{B_2}{z} = \frac{5}{5} = 1; \frac{B_1}{z} = \frac{0}{5} = 0$$

According to Figure 10.19, for these values of B_2/z and B_1/z , $I_2 = 0.24$. So,

$$\Delta\sigma_{z(1)} = 43.75(0.24) = 10.5 \text{ kN/m}^2$$

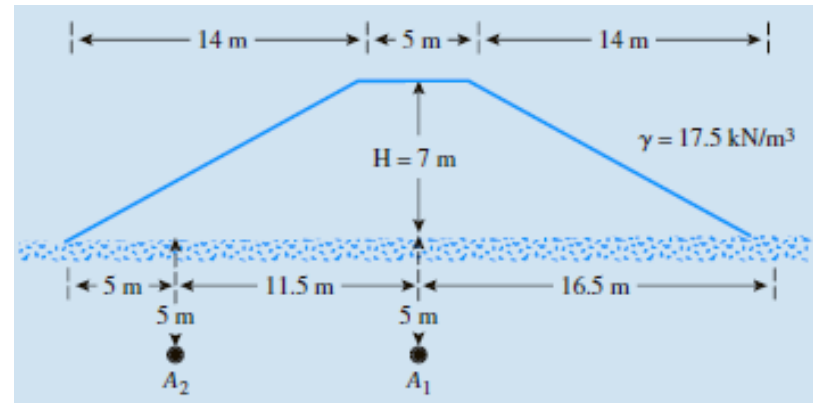

EXAMPLE 10.11

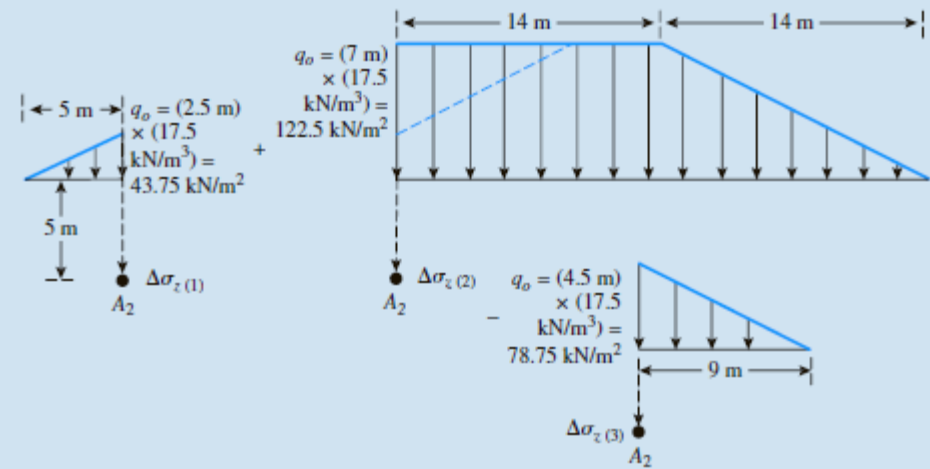
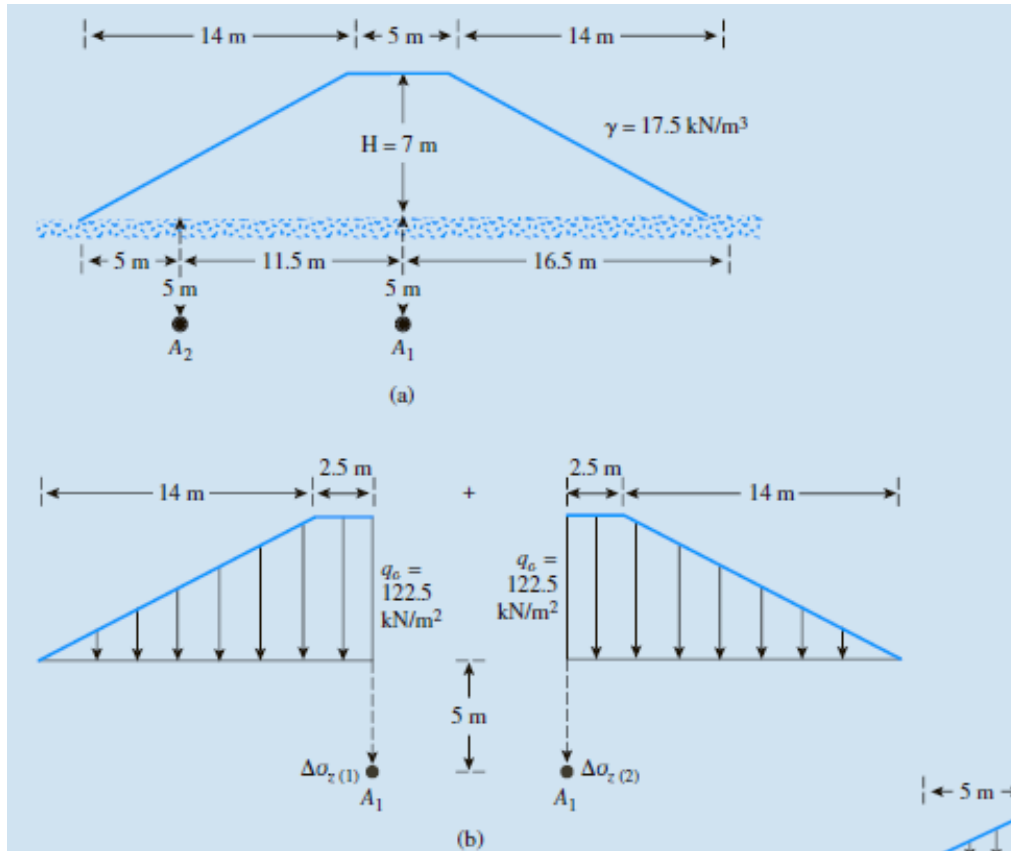

EXAMPLE 10.11

For the middle section,

$$\frac{B_2}{z} = \frac{14}{5} = 2.8; \frac{B_1}{z} = \frac{14}{5} = 2.8$$

Thus, $I_2 = 0.495$. So,

$$\Delta\sigma_{z(2)} = 0.495(122.5) = 60.64 \text{ kN/m}^2$$

For the right side,

$$\frac{B_2}{z} = \frac{9}{5} = 1.8; \frac{B_1}{z} = \frac{0}{5} = 0$$

and $I_2 = 0.335$. So,

$$\Delta\sigma_{z(3)} = (78.75)(0.335) = 26.38 \text{ kN/m}^2$$

Total stress increase at point A_2 is

$$\Delta\sigma_z = \Delta\sigma_{z(1)} + \Delta\sigma_{z(2)} - \Delta\sigma_{z(3)} = 10.5 + 60.64 - 26.38 = \mathbf{44.76 \text{ kN/m}^2}$$

Vertical Stress Below the Center of a Uniformly Loaded Circular Area

Using Boussinesq's solution for vertical stress σ_z caused by a point load one also can develop an expression for the vertical stress below the center of a uniformly loaded flexible circular area.

$$\Delta\sigma_z = q \left\{ 1 - \frac{1}{[(R/z)^2 + 1]^{3/2}} \right\}$$

Table 10.7 Variation of $\Delta\sigma_z/q$ with z/R [Eq. (10.27)]

z/R	$\Delta\sigma_z/q$	z/R	$\Delta\sigma_z/q$
0	1	1.0	0.6465
0.02	0.9999	1.5	0.4240
0.05	0.9998	2.0	0.2845
0.10	0.9990	2.5	0.1996
0.2	0.9925	3.0	0.1436
0.4	0.9488	4.0	0.0869
0.5	0.9106	5.0	0.0571
0.8	0.7562		

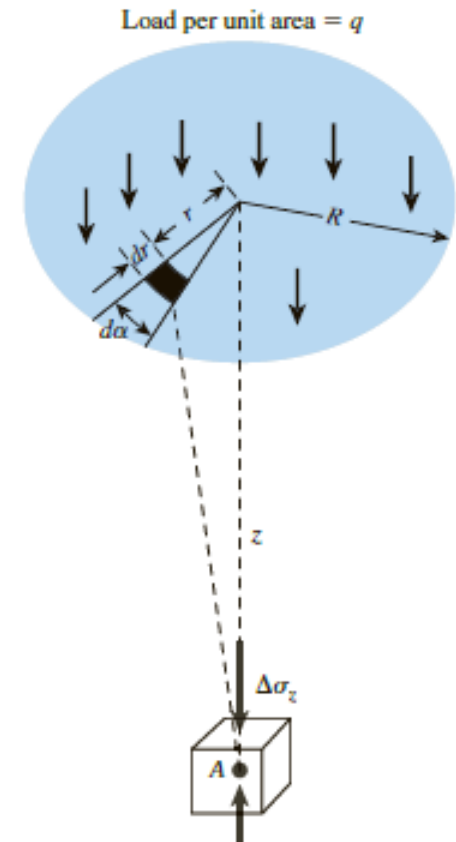

Vertical Stress at **Any Point** below a **Uniformly Loaded Circular Area**

$$\Delta\sigma_z = q(A' + B')$$

where A' and B' are functions of z/R and r/R .

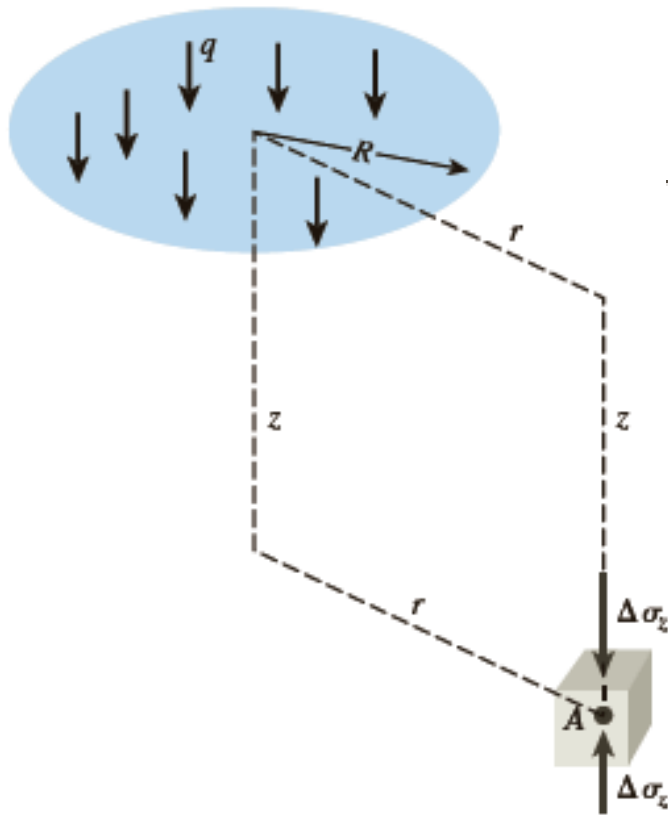

Figure 10.22 Vertical stress at any point below a uniformly loaded circular area

Vertical Stress at Any Point below a Uniformly Loaded Circular Area

Table 10.8 Variation of A' with z/R and r/R *

z/R	r/R								
	0	0.2	0.4	0.6	0.8	1	1.2	1.5	2
0	1.0	1.0	1.0	1.0	1.0	0.5	0	0	0
0.1	0.90050	0.89748	0.88679	0.86126	0.78797	0.43015	0.09645	0.02787	0.00856
0.2	0.80388	0.79824	0.77884	0.73483	0.63014	0.38269	0.15433	0.05251	0.01680
0.3	0.71265	0.70518	0.68316	0.62690	0.52081	0.34375	0.17964	0.07199	0.02440
0.4	0.62861	0.62015	0.59241	0.53767	0.44329	0.31048	0.18709	0.08593	0.03118
0.5	0.55279	0.54403	0.51622	0.46448	0.38390	0.28156	0.18556	0.09499	0.03701
0.6	0.48550	0.47691	0.45078	0.40427	0.33676	0.25588	0.17952	0.10010	
0.7	0.42654	0.41874	0.39491	0.35428	0.29833	0.21727	0.17124	0.10228	0.04558
0.8	0.37531	0.36832	0.34729	0.31243	0.26581	0.21297	0.16206	0.10236	
0.9	0.33104	0.32492	0.30669	0.27707	0.23832	0.19488	0.15253	0.10094	
1	0.29289	0.28763	0.27005	0.24697	0.21468	0.17868	0.14329	0.09849	0.05185
1.2	0.23178	0.22795	0.21662	0.19890	0.17626	0.15101	0.12570	0.09192	0.05260
1.5	0.16795	0.16552	0.15877	0.14804	0.13436	0.11892	0.10296	0.08048	0.05116
2	0.10557	0.10453	0.10140	0.09647	0.09011	0.08269	0.07471	0.06275	0.04496
2.5	0.07152	0.07098	0.06947	0.06698	0.06373	0.05974	0.05555	0.04880	0.03787
3	0.05132	0.05101	0.05022	0.04886	0.04707	0.04487	0.04241	0.03839	0.03150
4	0.02986	0.02976	0.02907	0.02802	0.02832	0.02749	0.02651	0.02490	0.02193
5	0.01942	0.01938				0.01835			0.01573
6	0.01361					0.01307			0.01168
7	0.01005					0.00976			0.00894
8	0.00772					0.00755			0.00703
9	0.00612					0.00600			0.00566
10								0.00477	0.00465

Vertical Stress at **Any Point** below a **Uniformly Loaded Circular Area**

Table 10.8 (continued)

z/R	r/R								
	3	4	5	6	7	8	10	12	14
0	0	0	0	0	0	0	0	0	0
0.1	0.00211	0.00084	0.00042						
0.2	0.00419	0.00167	0.00083	0.00048	0.00030	0.00020			
0.3	0.00622	0.00250							
0.4									
0.5	0.01013	0.00407	0.00209	0.00118	0.00071	0.00053	0.00025	0.00014	0.00009
0.6									
0.7									
0.8									
0.9									
1	0.01742	0.00761	0.00393	0.00226	0.00143	0.00097	0.00050	0.00029	0.00018
1.2	0.01935	0.00871	0.00459	0.00269	0.00171	0.00115			
1.5	0.02142	0.01013	0.00548	0.00325	0.00210	0.00141	0.00073	0.00043	0.00027
2	0.02221	0.01160	0.00659	0.00399	0.00264	0.00180	0.00094	0.00056	0.00036
2.5	0.02143	0.01221	0.00732	0.00463	0.00308	0.00214	0.00115	0.00068	0.00043
3	0.01980	0.01220	0.00770	0.00505	0.00346	0.00242	0.00132	0.00079	0.00051
4	0.01592	0.01109	0.00768	0.00536	0.00384	0.00282	0.00160	0.00099	0.00065
5	0.01249	0.00949	0.00708	0.00527	0.00394	0.00298	0.00179	0.00113	0.00075
6	0.00983	0.00795	0.00628	0.00492	0.00384	0.00299	0.00188	0.00124	0.00084
7	0.00784	0.00661	0.00548	0.00445	0.00360	0.00291	0.00193	0.00130	0.00091
8	0.00635	0.00554	0.00472	0.00398	0.00332	0.00276	0.00189	0.00134	0.00094
9	0.00520	0.00466	0.00409	0.00353	0.00301	0.00256	0.00184	0.00133	0.00096
10	0.00438	0.00397	0.00352	0.00326	0.00273	0.00241			

Vertical Stress at Any Point below a Uniformly Loaded Circular Area

Table 10.9 Variation of B' with z/R and r/R^*

z/R	r/R								
	0	0.2	0.4	0.6	0.8	1	1.2	1.5	2
0	0	0	0	0	0	0	0	0	0
0.1	0.09852	0.10140	0.11138	0.13424	0.18796	0.05388	-0.07899	-0.02672	-0.00845
0.2	0.18857	0.19306	0.20772	0.23524	0.25983	0.08513	-0.07759	-0.04448	-0.01593
0.3	0.26362	0.26787	0.28018	0.29483	0.27257	0.10757	-0.04316	-0.04999	-0.02166
0.4	0.32016	0.32259	0.32748	0.32273	0.26925	0.12404	-0.00766	-0.04535	-0.02522
0.5	0.35777	0.35752	0.35323	0.33106	0.26236	0.13591	0.02165	-0.03455	-0.02651
0.6	0.37831	0.37531	0.36308	0.32822	0.25411	0.14440	0.04457	-0.02101	
0.7	0.38487	0.37962	0.36072	0.31929	0.24638	0.14986	0.06209	-0.00702	-0.02329
0.8	0.38091	0.37408	0.35133	0.30699	0.23779	0.15292	0.07530	0.00614	
0.9	0.36962	0.36275	0.33734	0.29299	0.22891	0.15404	0.08507	0.01795	
1	0.35355	0.34553	0.32075	0.27819	0.21978	0.15355	0.09210	0.02814	-0.01005
1.2	0.31485	0.30730	0.28481	0.24836	0.20113	0.14915	0.10002	0.04378	0.00023
1.5	0.25602	0.25025	0.23338	0.20694	0.17368	0.13732	0.10193	0.05745	0.01385
2	0.17889	0.18144	0.16644	0.15198	0.13375	0.11331	0.09254	0.06371	0.02836
2.5	0.12807	0.12633	0.12126	0.11327	0.10298	0.09130	0.07869	0.06022	0.03429
3	0.09487	0.09394	0.09099	0.08635	0.08033	0.07325	0.06551	0.05354	0.03511
4	0.05707	0.05666	0.05562	0.05383	0.05145	0.04773	0.04532	0.03995	0.03066
5	0.03772	0.03760				0.03384			0.02474
6	0.02666					0.02468			0.01968
7	0.01980					0.01868			0.01577
8	0.01526					0.01459			0.01279
9	0.01212					0.01170			0.01054
10								0.00924	0.00879

Vertical Stress at **Any Point** below a **Uniformly Loaded Circular Area**

Table 10.9 (continued)

z/R	r/R								
	3	4	5	6	7	8	10	12	14
0	0	0	0	0	0	0	0	0	0
0.1	-0.00210	-0.00084	-0.00042						
0.2	-0.00412	-0.00166	-0.00083	-0.00024	-0.00015	-0.00010			
0.3	-0.00599	-0.00245							
0.4									
0.5	-0.00991	-0.00388	-0.00199	-0.00116	-0.00073	-0.00049	-0.00025	-0.00014	-0.00009
0.6									
0.7									
0.8									
0.9									
1	-0.01115	-0.00608	-0.00344	-0.00210	-0.00135	-0.00092	-0.00048	-0.00028	-0.00018
1.2	-0.00995	-0.00632	-0.00378	-0.00236	-0.00156	-0.00107			
1.5	-0.00669	-0.00600	-0.00401	-0.00265	-0.00181	-0.00126	-0.00068	-0.00040	-0.00026
2	0.00028	0.00410	0.00371	0.00278	0.00202	0.00148	0.00084	0.00050	0.00033
2.5	0.00661	-0.00130	-0.00271	-0.00250	-0.00201	-0.00156	-0.00094	-0.00059	-0.00039
3	0.01112	0.00157	-0.00134	-0.00192	-0.00179	-0.00151	-0.00099	-0.00065	-0.00046
4	0.01515	0.00595	0.00155	-0.00029	-0.00094	-0.00109	-0.00094	-0.00068	-0.00050
5	0.01522	0.00810	0.00371	0.00132	0.00013	-0.00043	-0.00070	-0.00061	-0.00049
6	0.01380	0.00867	0.00496	0.00254	0.00110	0.00028	-0.00037	-0.00047	-0.00045
7	0.01204	0.00842	0.00547	0.00332	0.00185	0.00093	-0.00002	-0.00029	-0.00037
8	0.01034	0.00779	0.00554	0.00372	0.00236	0.00141	0.00035	0.00008	0.00025
9	0.00888	0.00705	0.00533	0.00386	0.00265	0.00178	0.00066	0.00012	-0.00012
10	0.00764	0.00631	0.00501	0.00382	0.00281	0.00199			

Vertical Stress at Any Point below a Uniformly Loaded Circular Area

Table 10.7 Variation of $\Delta\sigma_z/q$ with z/R [Eq. (10.27)]

z/R	$\Delta\sigma_z/q$	z/R	$\Delta\sigma_z/q$
0	1	1.0	0.6465
0.02	0.9999	1.5	0.4240
0.05	0.9998	2.0	0.2845
0.10	0.9990	2.5	0.1996
0.2	0.9925	3.0	0.1436
0.4	0.9488	4.0	0.0869
0.5	0.9106	5.0	0.0571
0.8	0.7562		

Table 10.8 Variation of A' with z/R and r/R^*

z/R	0	0.2	0.4	0.6
0	1.0	1.0	1.0	1.0
0.1	0.90050	0.89748	0.88679	0.86126
0.2	0.80388	0.79824	0.77884	0.73483
0.3	0.71265	0.70518	0.68316	0.62690
0.4	0.62861	0.62015	0.59241	0.53767
0.5	0.55279	0.54403	0.51622	0.46448
0.6	0.48550	0.47691	0.45078	0.40427
0.7	0.42654	0.41874	0.39491	0.35428
0.8	0.37531	0.36832	0.34729	0.31243
0.9	0.33104	0.32492	0.30669	0.27707
1	0.29289	0.28763	0.27005	0.24697
1.2	0.23178	0.22795	0.21662	0.19890
1.5	0.16795	0.16552	0.15877	0.14804
2	0.10557	0.10453	0.10140	0.09647
2.5	0.07152	0.07098	0.06947	0.06698
3	0.05132	0.05101	0.05022	0.04886
4	0.02986	0.02976	0.02907	0.02802
5	0.01942	0.01938		

Table 10.9 Variation of B' with z/R and r/R^*

z/R	0	0.2	0.4	0.6
0	0	0	0	0
0.1	0.09852	0.10140	0.11138	0.13424
0.2	0.18857	0.19306	0.20772	0.23524
0.3	0.26362	0.26787	0.28018	0.29483
0.4	0.32016	0.32259	0.32748	0.32273
0.5	0.35777	0.35752	0.35323	0.33106
0.6	0.37831	0.37531	0.36308	0.32822
0.7	0.38487	0.37962	0.36072	0.31929
0.8	0.38091	0.37408	0.35133	0.30699
0.9	0.36962	0.36275	0.33734	0.29299
1	0.35355	0.34553	0.32075	0.27819
1.2	0.31485	0.30730	0.28481	0.24836
1.5	0.25602	0.25025	0.23338	0.20694
2	0.17889	0.18144	0.16644	0.15198
2.5	0.12807	0.12633	0.12126	0.11327
3	0.09487	0.09394	0.09099	0.08635
4	0.05707	0.05666	0.05562	0.05383
5	0.03772	0.03760		

$$\Delta\sigma_z = q(A' + B')$$

Below the center

$r/R = 0$

For $z/R=0.2$

$A'=0.80388$ (Table 10.8), $B'= 0.18857$ (Table 10.9)

$I= 0.80388 +0.18857= 0.99245$ same as from Table 10.7

EXAMPLE 10.12

Example 10.12

Consider a uniformly loaded flexible circular area on the ground surface, as shown in Fig. 10.22. Given: $R = 3$ m and uniform load $q = 100$ kN/m².

Calculate the increase in vertical stress at depths of 1.5, 3, 4.5, 6, and 12 m below the ground surface for points at (a) $r = 0$ and (b) $r = 4.5$ m.

Solution

From Eq. (10.28),

$$\Delta\sigma_z = q(A' + B')$$

Given $R = 3$ m and $q = 100$ kN/m².

Part a

We can prepare the following table. (Note: $r/R = 0$. A' and B' values are from Tables 10.8 and 10.9.)

Depth, z (m)	z/R	A'	B'	$\Delta\sigma_z$ (kN/m ²)
1.5	0.5	0.553	0.358	91.1
3	1.0	0.293	0.354	64.7
4.5	1.5	0.168	0.256	42.4
6	2.0	0.106	0.179	28.5
12	4.0	0.03	0.057	8.7

Part b

$$r/R = 4.5/3 = 1.5$$

Depth, z (m)	z/R	A'	B'	$\Delta\sigma_z$ (kN/m ²)
1.5	0.5	0.095	0.035	6.0
3	1.0	0.098	0.028	12.6
4.5	1.5	0.08	0.057	13.7
6	2.0	0.063	0.064	12.7
12	4.0	0.025	0.04	6.5

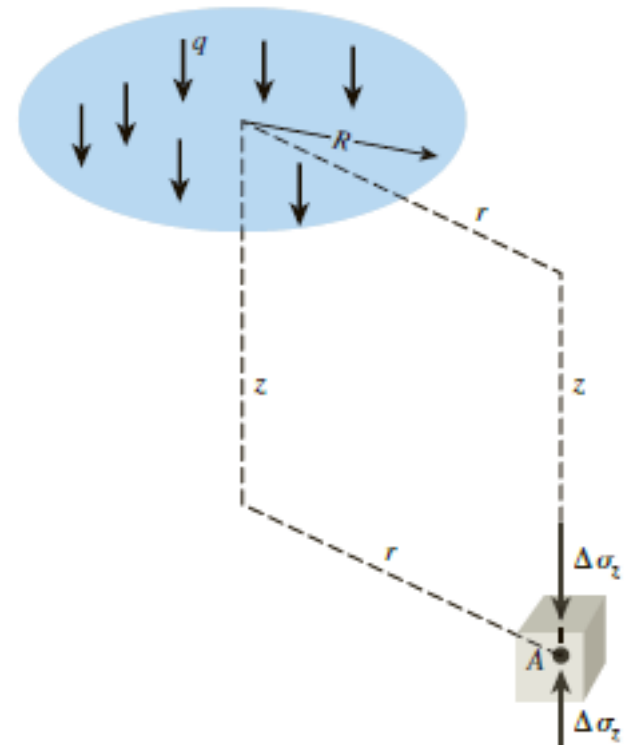

EXAMPLE

Circular tank, 25 m diameter with bearing pressure $P = 122$ kPa.
Find stress induced by the tank 10 m below the edge.

$$\Delta\sigma_z = q(A' + B')$$

$$\begin{aligned} R &= 12.5 \text{ m} \\ r &= 12.5 \text{ m} \\ z &= 10 \text{ m} \\ r/R &= 1 \\ z/R &= 0.8 \end{aligned}$$

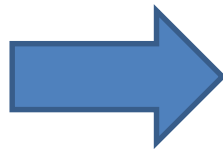

$$\begin{aligned} A' &= 0.213 \\ B' &= 0.153 \end{aligned}$$

$$\Delta\sigma_z = (0.213 + 0.153) \times 122 = 44.65 \text{ kPa}$$

Vertical Stress Caused by a Rectangularly Loaded Area

- Recall **Boussinesq's** solution for point load:

$$\Delta\sigma_z = \frac{3P}{2\pi L^3} \frac{z^3}{(r^2 + z^2)^{5/2}}$$

- Boussinesq's solution also can be used to calculate the vertical stress increase below a flexible rectangular loaded area
- Consider a small elemental area **dx dy** of the rectangle
- The load on this elemental area can be given by

$$dq = q \, dx \, dy$$

- we need to replace **P** with **dq = q dx dy** and **r²** with **x²+ y²**. Thus,

$$\Delta\sigma_z = \frac{3P}{2\pi L^3} \frac{z^3}{(r^2 + z^2)^{5/2}}$$

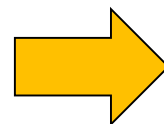

$$d\sigma_z = \frac{3q \, dx \, dy \, z^3}{2\pi(x^2 + y^2 + z^2)^{5/2}}$$

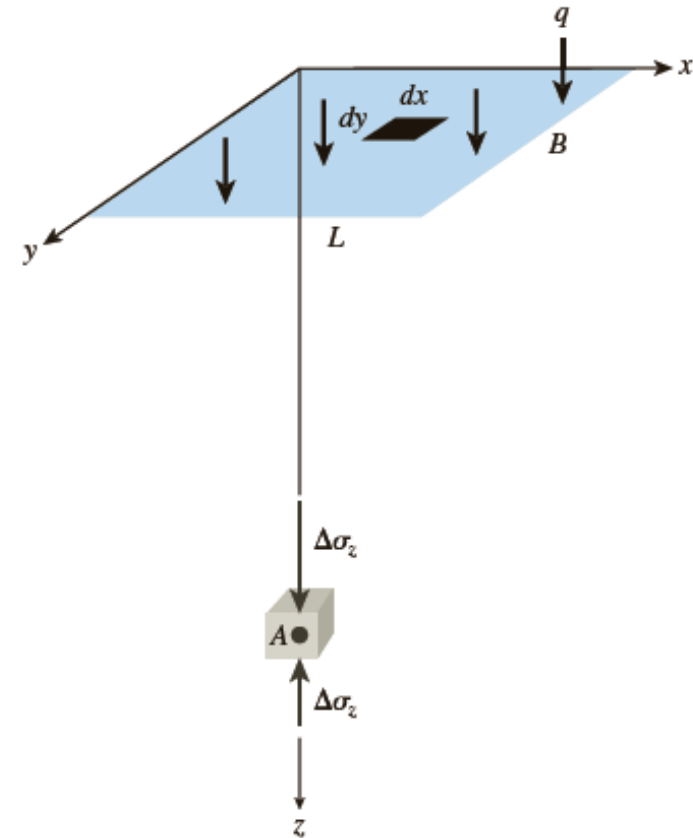

Vertical Stress Caused by a Rectangularly Loaded Area

Corner of the rectangular area

- The increase in the stress, at point **A** caused by the **entire** loaded area can now be determined by integrating the preceding equation. We obtain

$$\Delta\sigma_z = \int d\sigma_z = \int_{y=0}^B \int_{x=0}^L \frac{3qz^3(dx dy)}{2\pi(x^2 + y^2 + z^2)^{5/2}} = qI_3$$

$$I_3 = \frac{1}{4\pi} \left[\frac{2mn\sqrt{m^2 + n^2 + 1}}{m^2 + n^2 + m^2n^2 + 1} \left(\frac{m^2 + n^2 + 2}{m^2 + n^2 + 1} \right) + \tan^{-1} \left(\frac{2mn\sqrt{m^2 + n^2 + 1}}{m^2 + n^2 - m^2n^2 + 1} \right) \right] \quad \text{Eq. 10.32}$$

$$n = \frac{L}{z}$$

$$m = \frac{B}{z}$$

The arctangent term in Eq. (10.32) must be a **positive angle** in radians. When $m^2 + n^2 + 1 < m^2 n^2$, it becomes a negative angle. So a term π should be added to that angle.

Vertical Stress Caused by a Rectangularly Loaded Area

Table 10.10 Variation of I_3 with m and n [Eq. (10.32)]

n	m									
	0.1	0.2	0.3	0.4	0.5	0.6	0.7	0.8	0.9	1.0
0.1	0.0047	0.0092	0.0132	0.0168	0.0198	0.0222	0.0242	0.0258	0.0270	0.0279
0.2	0.0092	0.0179	0.0259	0.0328	0.0387	0.0435	0.0474	0.0504	0.0528	0.0547
0.3	0.0132	0.0259	0.0374	0.0474	0.0559	0.0629	0.0686	0.0731	0.0766	0.0794
0.4	0.0168	0.0328	0.0474	0.0602	0.0711	0.0801	0.0873	0.0931	0.0977	0.1013
0.5	0.0198	0.0387	0.0559	0.0711	0.0840	0.0947	0.1034	0.1104	0.1158	0.1202
0.6	0.0222	0.0435	0.0629	0.0801	0.0947	0.1069	0.1168	0.1247	0.1311	0.1361
0.7	0.0242	0.0474	0.0686	0.0873	0.1034	0.1169	0.1277	0.1365	0.1436	0.1491
0.8	0.0258	0.0504	0.0731	0.0931	0.1104	0.1247	0.1365	0.1461	0.1537	0.1598
0.9	0.0270	0.0528	0.0766	0.0977	0.1158	0.1311	0.1436	0.1537	0.1619	0.1684
1.0	0.0279	0.0547	0.0794	0.1013	0.1202	0.1361	0.1491	0.1598	0.1684	0.1752
1.2	0.0293	0.0573	0.0832	0.1063	0.1263	0.1431	0.1570	0.1684	0.1777	0.1851
1.4	0.0301	0.0589	0.0856	0.1094	0.1300	0.1475	0.1620	0.1739	0.1836	0.1914
1.6	0.0306	0.0599	0.0871	0.1114	0.1324	0.1503	0.1652	0.1774	0.1874	0.1955
1.8	0.0309	0.0606	0.0880	0.1126	0.1340	0.1521	0.1672	0.1797	0.1899	0.1981
2.0	0.0311	0.0610	0.0887	0.1134	0.1350	0.1533	0.1686	0.1812	0.1915	0.1999
2.5	0.0314	0.0616	0.0895	0.1145	0.1363	0.1548	0.1704	0.1832	0.1938	0.2024
3.0	0.0315	0.0618	0.0898	0.1150	0.1368	0.1555	0.1711	0.1841	0.1947	0.2034
4.0	0.0316	0.0619	0.0901	0.1153	0.1372	0.1560	0.1717	0.1847	0.1954	0.2042
5.0	0.0316	0.0620	0.0901	0.1154	0.1374	0.1561	0.1719	0.1849	0.1956	0.2044
6.0	0.0316	0.0620	0.0902	0.1154	0.1374	0.1562	0.1719	0.1850	0.1957	0.2045

Vertical Stress Caused by a Rectangularly Loaded Area

Corner of the rectangular area

$$\Delta\sigma_z = ql_3$$

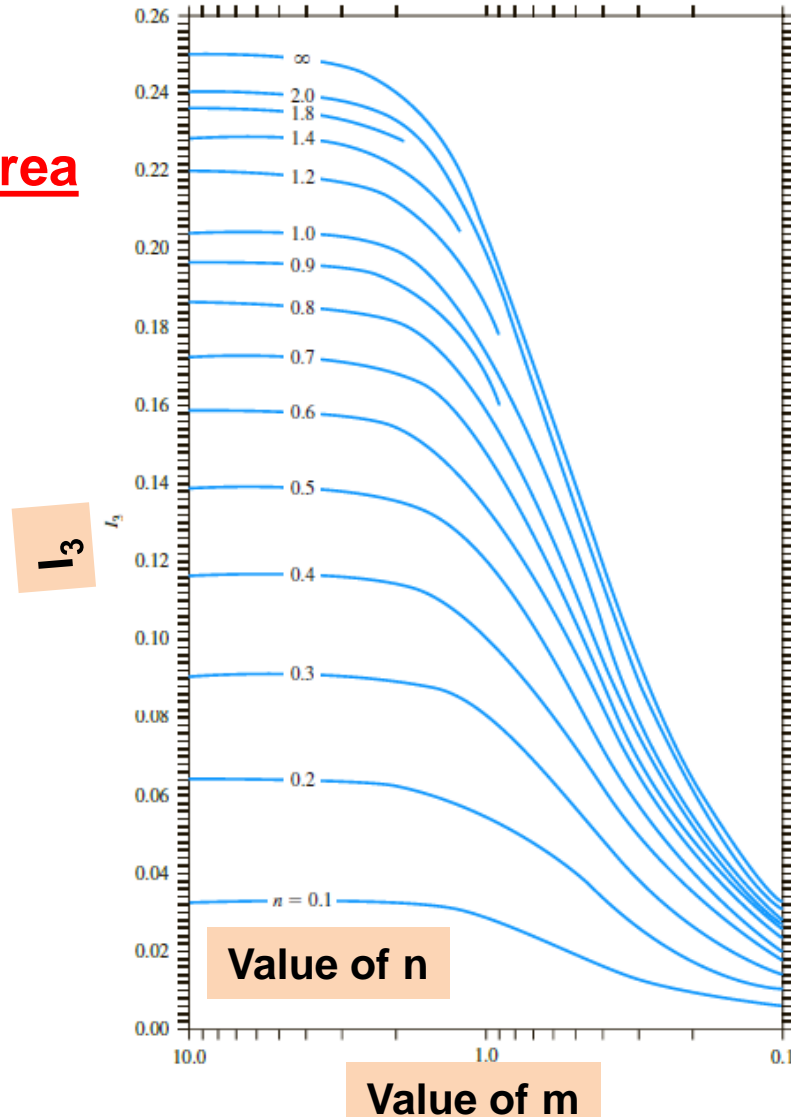

$$n = \frac{L}{z}$$

$$m = \frac{B}{z}$$

Vertical Stress Caused by a Rectangularly Loaded Area

The increase in the stress at any point below a rectangularly loaded area

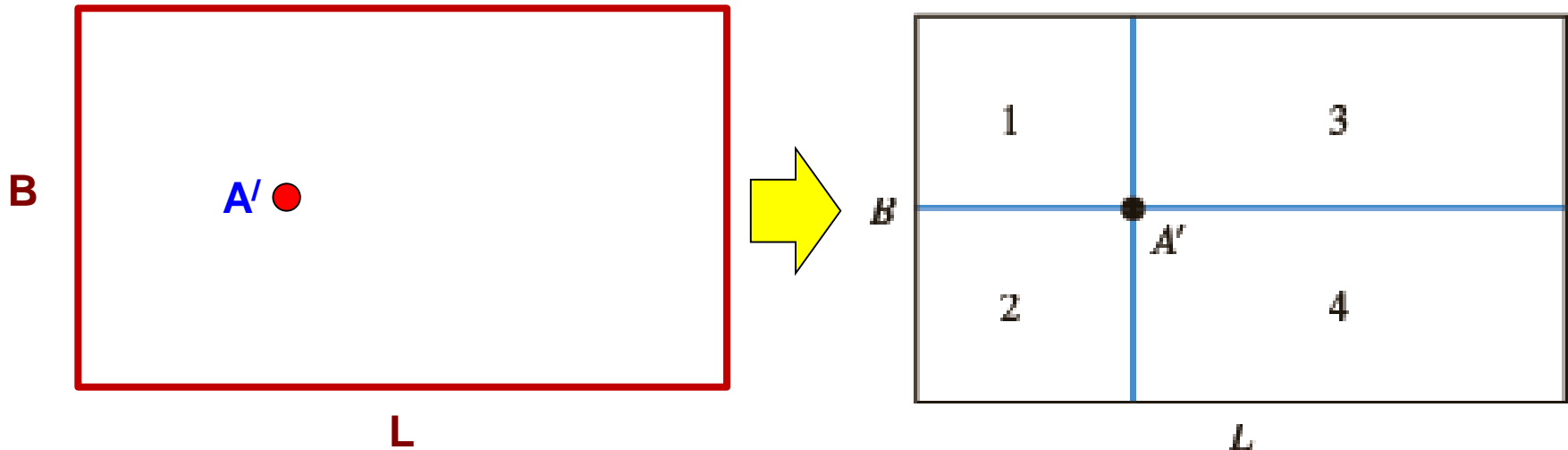

$$\Delta\sigma_z = q[I_{3(1)} + I_{3(2)} + I_{3(3)} + I_{3(4)}]$$

EXAMPLE 10.13

Example 10.13

The plan of a uniformly loaded rectangular area is shown in Figure 10.27a. Determine the vertical stress increase $\Delta\sigma_z$ below point A' at a depth of $z = 4$ m.

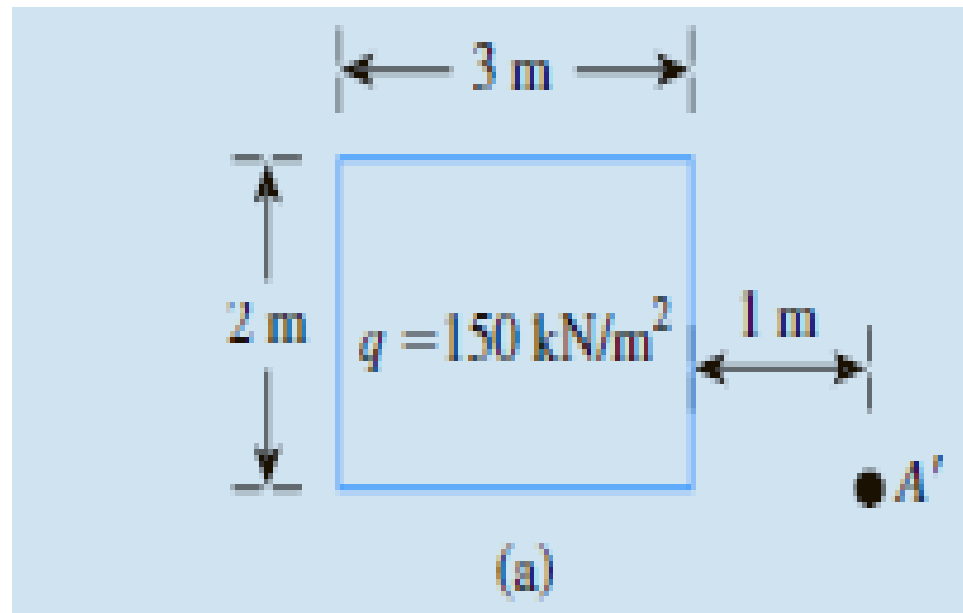

EXAMPLE 10.13

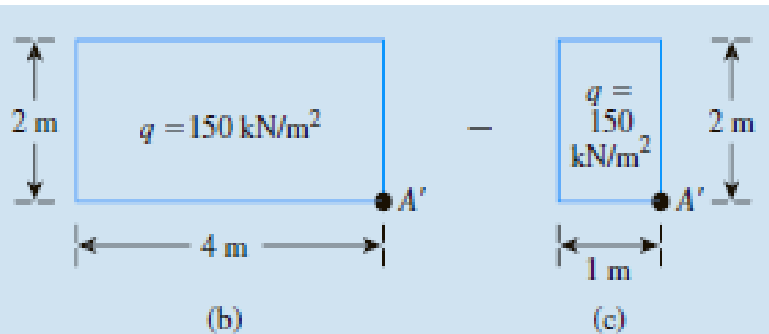
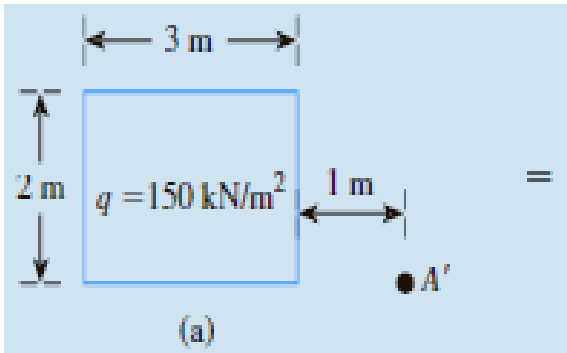

Solution

The stress increase $\Delta\sigma_z$ can be written as

$$\Delta\sigma_z = \Delta\sigma_{z(1)} - \Delta\sigma_{z(2)}$$

where

$\Delta\sigma_{z(1)}$ = stress increase due to the loaded area shown in Figure 10.27b

$\Delta\sigma_{z(2)}$ = stress increase due to the loaded area shown in Figure 10.27c

For the loaded area shown in Figure 10.27b:

$$m = \frac{B}{z} = \frac{2}{4} = 0.5$$

$$n = \frac{L}{z} = \frac{4}{4} = 1$$

From Figure 10.24 for $m = 0.5$ and $n = 1$, the value of $I_3 = 0.1225$. So

$$\Delta\sigma_{z(1)} = qI_3 = (150)(0.1225) = 18.38 \text{ kN/m}^2$$

Similarly, for the loaded area shown in Figure 10.27c:

$$m = \frac{B}{z} = \frac{1}{4} = 0.25$$

$$n = \frac{L}{z} = \frac{2}{4} = 0.5$$

Thus, $I_3 = 0.0473$. Hence,

$$\Delta\sigma_{z(2)} = (150)(0.0473) = 7.1 \text{ kN/m}^2$$

So

$$\Delta\sigma_z = \Delta\sigma_{z(1)} - \Delta\sigma_{z(2)} = 18.38 - 7.1 = 11.28 \text{ kN/m}^2$$

EXAMPLE

Determine the increase in stress at point **A** and **A'** below the footing shown below.

Solution

$$\Delta\sigma = q_0(I_1 + I_2 + I_3 + I_4)$$

$$I_1 = I_2 = I_3 = I_4$$

Then,

$$\Delta\sigma = 4q_0(I)$$

$$B = L = 1.5 \text{ m}$$

$$m_A = n_A = \frac{B \text{ or } L}{z_A} = \frac{1.5}{3} = 0.5, I_A = 0.084$$

$$m_{A'} = n_{A'} = \frac{B \text{ or } L}{z_{A'}} = \frac{1.5}{5} = 0.3, I_{A'} = 0.037$$

$$\Delta\sigma_A = 4 * 100 * 0.084 = 33.6 \text{ kPa}$$

$$\Delta\sigma_{A'} = 4 * 100 * 0.037 = 14.8 \text{ kPa}$$

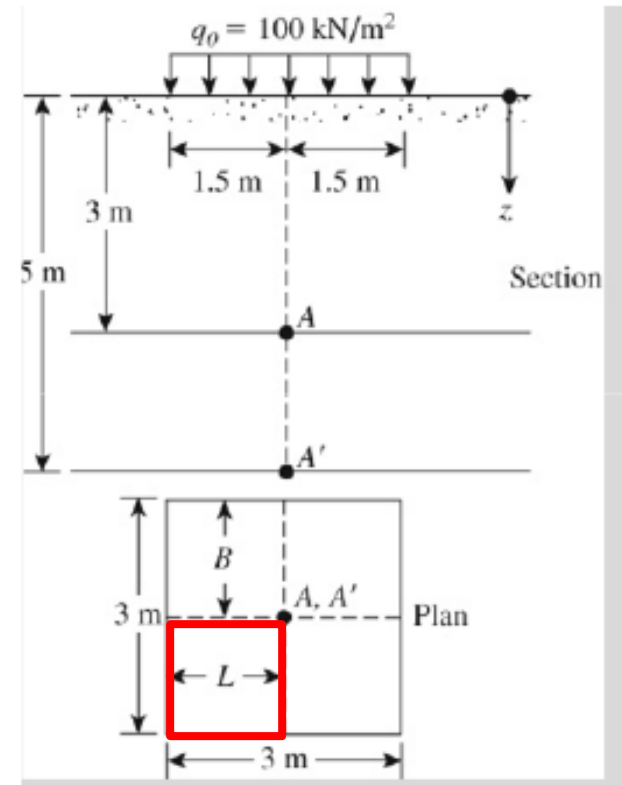

Vertical Stress Caused by a Rectangularly Loaded Area

Vertical stress increase below the center of a rectangular area

$$\Delta\sigma_z = qI_4$$

$$I_4 = \frac{2}{\pi} \left[\frac{m_1 n_1}{\sqrt{1 + m_1^2 + n_1^2}} \frac{1 + m_1^2 + 2n_1^2}{(1 + n_1^2)(m_1^2 + n_1^2)} + \sin^{-1} \frac{m_1}{\sqrt{m_1^2 + n_1^2} \sqrt{1 + n_1^2}} \right]$$

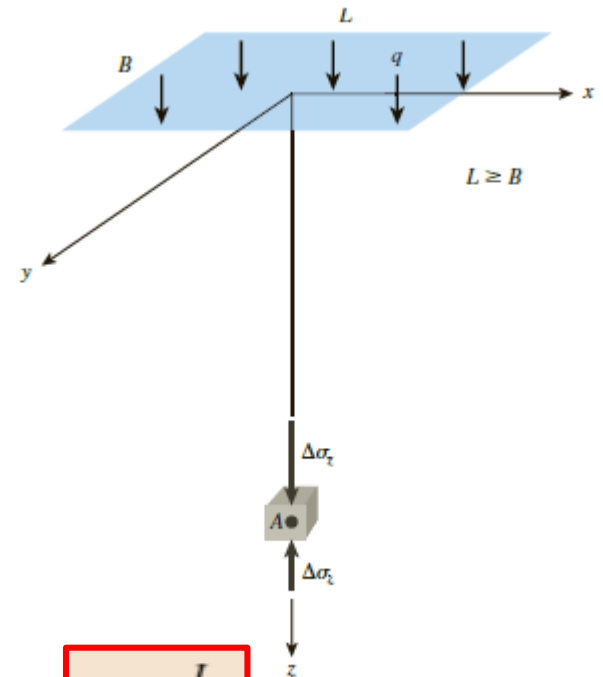

Table 10.11 Variation of I_4 with m_1 and n_1 [Eq. (10.37)]

n_1	m_1									
	1	2	3	4	5	6	7	8	9	10
0.20	0.994	0.997	0.997	0.997	0.997	0.997	0.997	0.997	0.997	0.997
0.40	0.960	0.976	0.977	0.977	0.977	0.977	0.977	0.977	0.977	0.977
0.60	0.892	0.932	0.936	0.936	0.937	0.937	0.937	0.937	0.937	0.937
0.80	0.800	0.870	0.878	0.880	0.881	0.881	0.881	0.881	0.881	0.881
1.00	0.701	0.800	0.814	0.817	0.818	0.818	0.818	0.818	0.818	0.818
1.20	0.606	0.727	0.748	0.753	0.754	0.755	0.755	0.755	0.755	0.755
1.40	0.522	0.658	0.685	0.692	0.694	0.695	0.695	0.696	0.696	0.696
1.60	0.449	0.593	0.627	0.636	0.639	0.640	0.641	0.641	0.641	0.642
1.80	0.388	0.534	0.573	0.585	0.590	0.591	0.592	0.592	0.593	0.593
2.00	0.336	0.481	0.525	0.540	0.545	0.547	0.548	0.549	0.549	0.549
3.00	0.179	0.293	0.348	0.373	0.384	0.389	0.392	0.393	0.394	0.395
4.00	0.108	0.190	0.241	0.269	0.285	0.293	0.298	0.301	0.302	0.303
5.00	0.072	0.131	0.174	0.202	0.219	0.229	0.236	0.240	0.242	0.244
6.00	0.051	0.095	0.130	0.155	0.172	0.184	0.192	0.197	0.200	0.202
7.00	0.038	0.072	0.100	0.122	0.139	0.150	0.158	0.164	0.168	0.171
8.00	0.029	0.056	0.079	0.098	0.113	0.125	0.133	0.139	0.144	0.147
9.00	0.023	0.045	0.064	0.081	0.094	0.105	0.113	0.119	0.124	0.128
10.00	0.019	0.037	0.053	0.067	0.079	0.089	0.097	0.103	0.108	0.112

$$m_1 = \frac{L}{B}$$

$$n_1 = \frac{z}{b}$$

$$b = \frac{B}{2}$$

EXAMPLE

Determine the increase in stress at point **A** and **A'** below the footing shown below.

Solution by below the center of a rectangular area

$$m_1 = \frac{L}{B} = \frac{3}{3} = 1 \quad b = \frac{B}{2} = \frac{3}{2} = 1.5$$

Point A

$$n_1 = \frac{z}{b} = \frac{3}{1.5} = 2$$

For $m_1 = 1$ and $n_1 = 2$ $\Rightarrow I_4 = 0.336$ (Table 10.11)

$$\Delta\sigma_z = 0.336 \times 100 = \underline{33.6 \text{ kPa}}$$

Point A'

$$n_1 = \frac{z}{b} = \frac{5}{1.5} = 3.33$$

For $m_1 = 1$ and $n_1 = 3.33$ $\Rightarrow I_4 = 0.155$ (Table 10.11)

$$\Delta\sigma_z = 0.155 \times 100 = \underline{15.5 \text{ kPa}}$$

Interpolate from the table

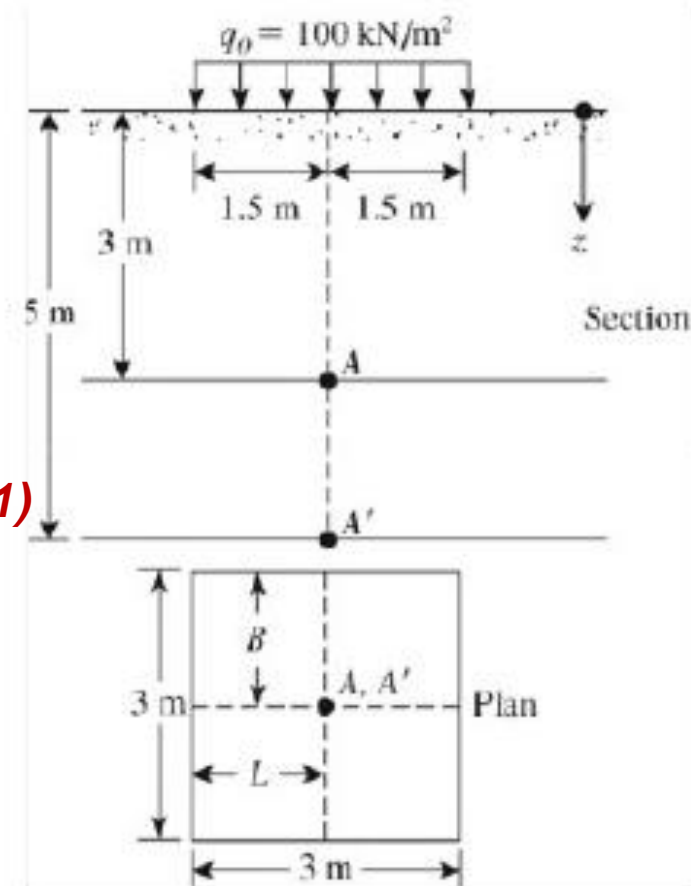

EXAMPLE

For the flexible footing shown below, determine the increase in the vertical stress at depth of $z = 5$ below **point C** for the uniformly distributed surface load q .

Solution

To solve the problem, expand the footing to reach the point C.

The “new” footing is a 13 by 5 .

The influence value I_3 is found for this condition,

$$m = B/z = 5/5 = 1$$

$$n = L/z = 13/5 = 2.6$$

therefore $I_3 = \underline{0.200}$

Now the shaded expanded area of 3 x 5 is also analyzed and then subtracted from the previous result.

$$m = B/z = 3/5 = 0.6$$

$$n = L/z = 5/5 = 1$$

therefore $I_3' = \underline{0.137}$

Therefore $\Delta p = q(I_3 - I_3') = (1800)(0.200 - 0.137) = \underline{117}$

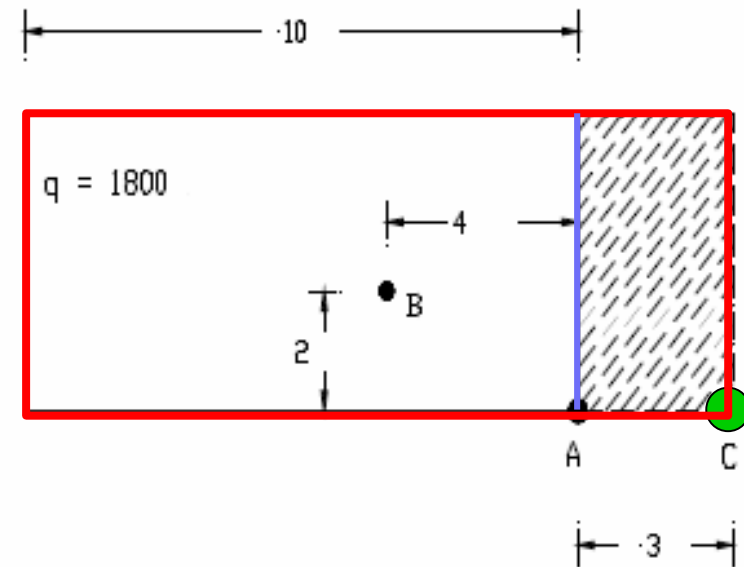

Some Possible Cases

Loaded area: ABCD

Case I

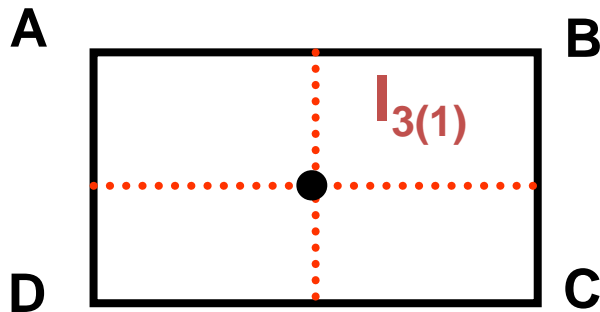

$$I_3 = 4I_{3(1)}$$

Case II

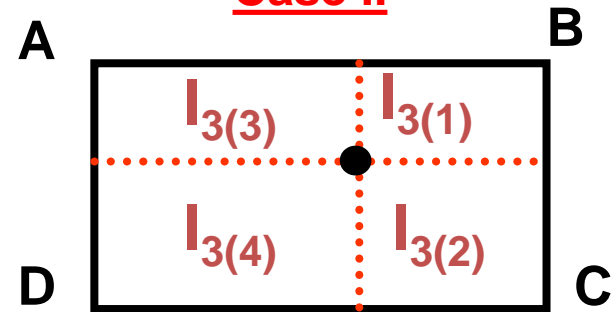

$$I_3 = I_{3(1)} + I_{3(2)} + I_{3(3)} + I_{3(4)}$$

Some Possible Cases

Loaded area: **ABCD**

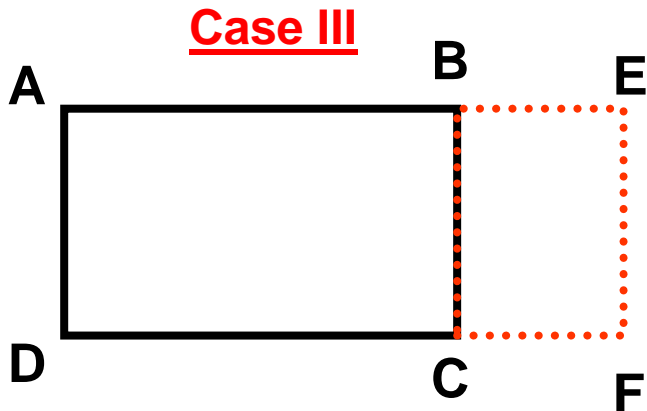

$$I_3 = I_3(\text{AEFD}) - I_3(\text{BEFC})$$

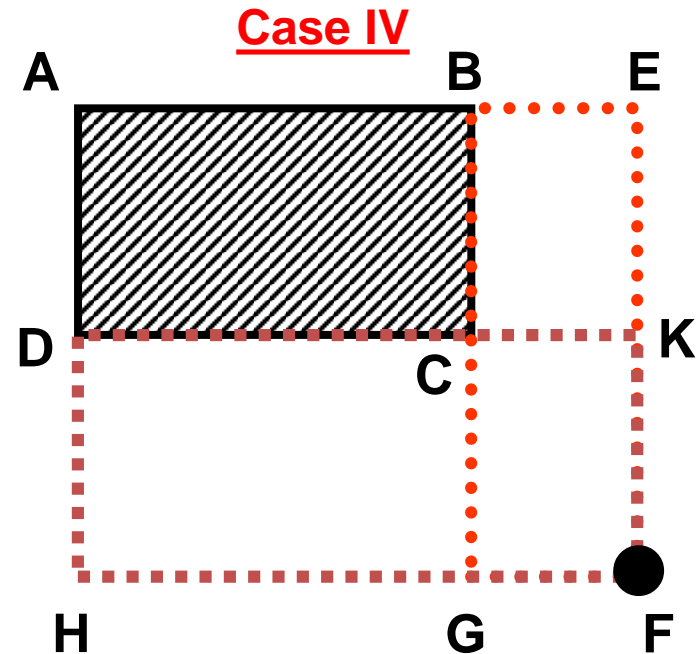

$$I_3 = I_3(\text{HAEF}) - I_3(\text{GBEF}) - I_3(\text{HDKF}) + I_3(\text{GCKF})$$

Newmark's Influence Chart

- Newmark (1942) constructed an influence chart based on the Boussinesq's solution.
- This chart can be used to determine the vertical stress at any point below uniformly loaded flexible area of any shape.
- Using the value of (R/z) obtained from Eq. (*) for various pressure ratios (i.e $\Delta\sigma_z/q$), Newmark (1942) presented an influence chart that can be used to determine the vertical pressure at any point below a uniformly loaded flexible area of any shape.

Table 10.12 Values of R/z for Various Pressure Ratios [Eq. (10.41)]

$\Delta\sigma_z/q$	R/z	$\Delta\sigma_z/q$	R/z
0	0	0.55	0.8384
0.05	0.1865	0.60	0.9176
0.10	0.2698	0.65	1.0067
0.15	0.3383	0.70	1.1097
0.20	0.4005	0.75	1.2328
0.25	0.4598	0.80	1.3871
0.30	0.5181	0.85	1.5943
0.35	0.5768	0.90	1.9084
0.40	0.6370	0.95	2.5232
0.45	0.6997	1.00	∞
0.50	0.7664		

$$\frac{R}{z} = \sqrt{\left(1 - \frac{\Delta\sigma_z}{q}\right)^{-\frac{2}{3}} - 1} \quad (*)$$

Newmark's Influence Chart

- The radii of the circles are equal to (R/z) values corresponding to

$$\Delta\sigma_z/q = 0, 0.1, 0.2, \dots, 1$$

Note:

For $\Delta\sigma_z/q = 0$, $R/z = 0$, and for $\sigma_z/q = 1$, $R/z = \infty$, so nine circles are shown

- The unit length for plotting the circle is \overline{AB}
- The **circles** are divided by equally spaced **radial** lines

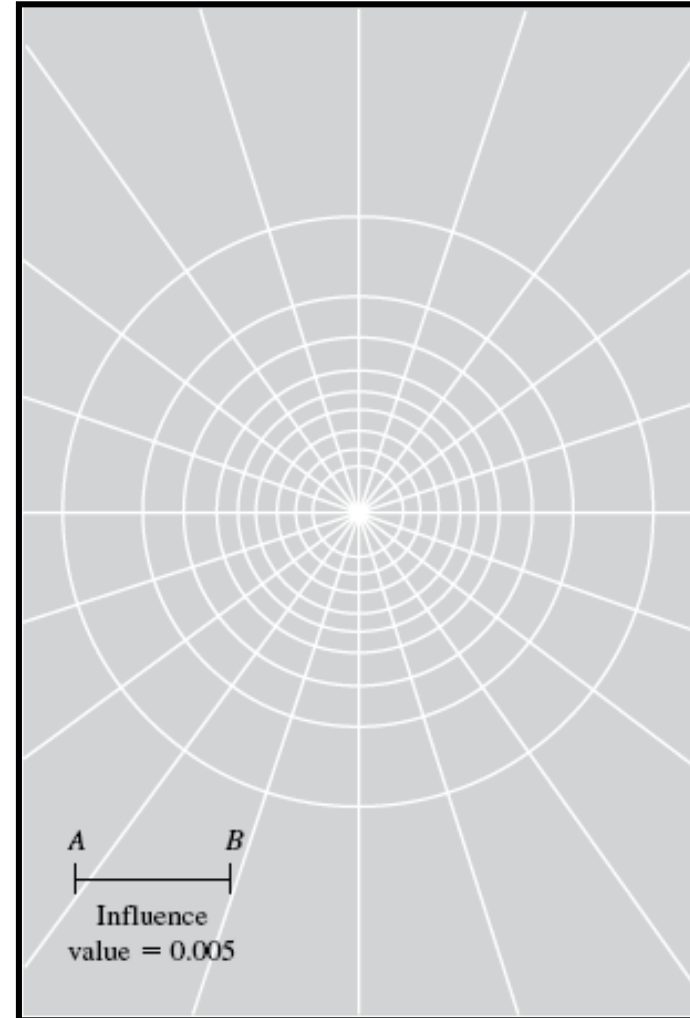

Newmark's Influence Chart

- The influence value of the chart is given by $1/N$, where N is equal to the number of elements in the chart.
- In the shown chart, there are **200** elements; hence the influence value is **0.005**.
- The **area** of each **segment** represents an equal **proportion** of the applied surface stress at a depth **z** below the surface.

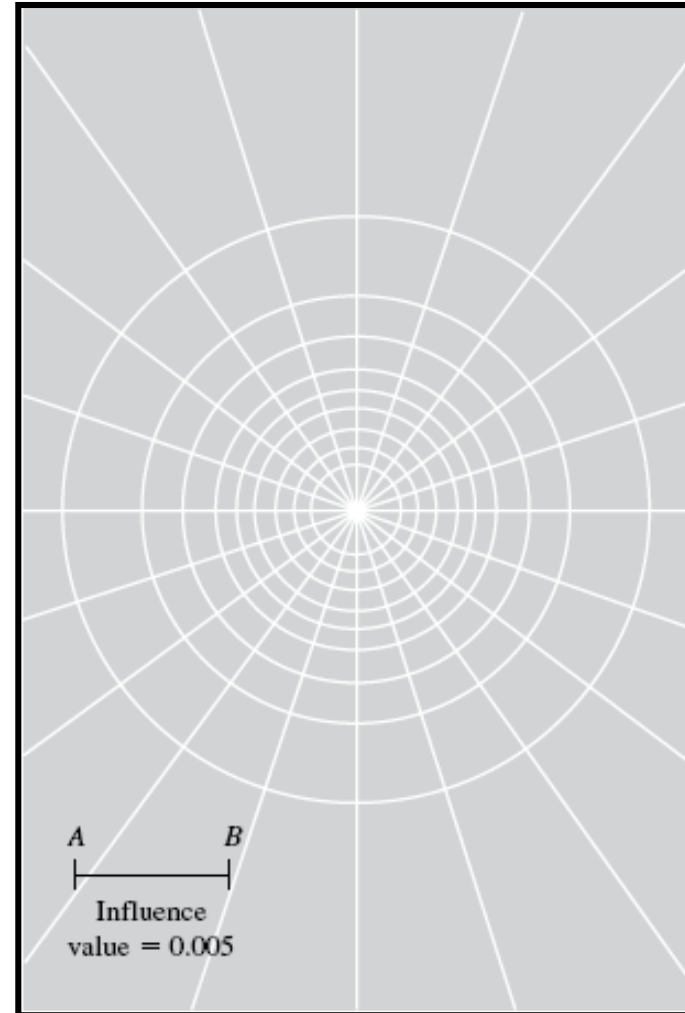

Procedures for Using the Chart

The procedure for obtaining vertical pressure at any point below a loaded area is as follows:

1. Determine the depth z below the uniformly loaded area at which the stress increase is required.
2. Plot the plan of the loaded area with a scale of z equal to the unit length of the chart (\overline{AB}).
3. Place the plan (plotted in step 2) on the influence chart in such a way that the point below which the stress is to be determined is located at the center of the chart.
4. Count the number of elements (M) of the chart enclosed by the plan of the loaded area.

The increase in the pressure at the point under consideration is given by

$$\Delta\sigma_z = (IV)qM$$

where IV = influence value

q = pressure on the loaded area

EXAMPLE 10.14

Example 10.14

The cross section and plan of a column foundation are shown in Figure 10.29a. Find the increase in vertical stress produced by the column footing at point A .

Solution

Point A is located at a depth 3 m below the bottom of the foundation. The plan of the square foundation has been replotted to a scale of $\overline{AB} = 3$ m and placed on the influence chart (Figure 10.29b) in such a way that point A on the plan falls directly over the center of the chart. The number of elements inside the outline of the plan is about 48.5. Hence,

$$\Delta\sigma_z = (IV)qM = 0.005\left(\frac{660}{3 \times 3}\right)48.5 = 17.78 \text{ kN/m}^2$$

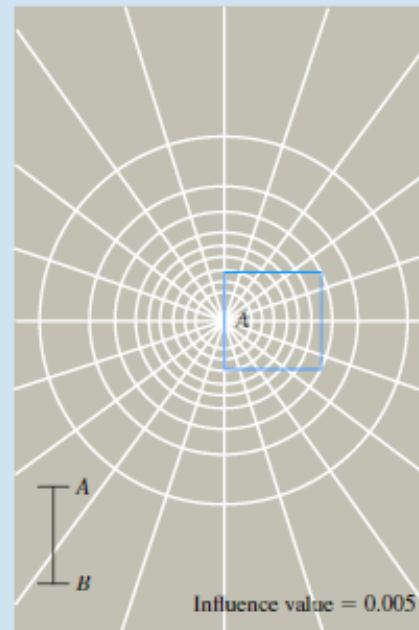
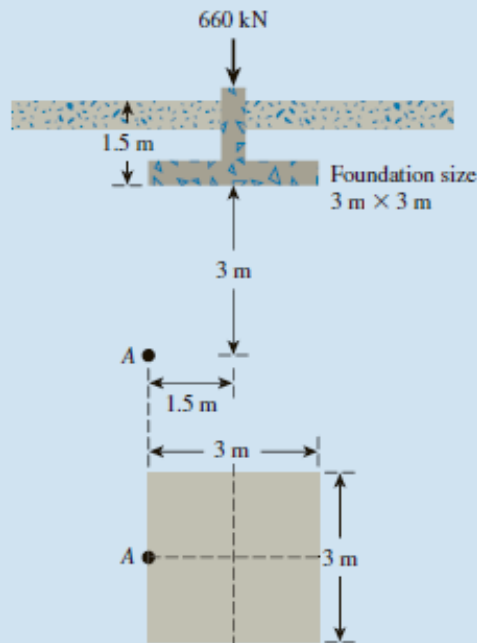

EXAMPLE 10.13

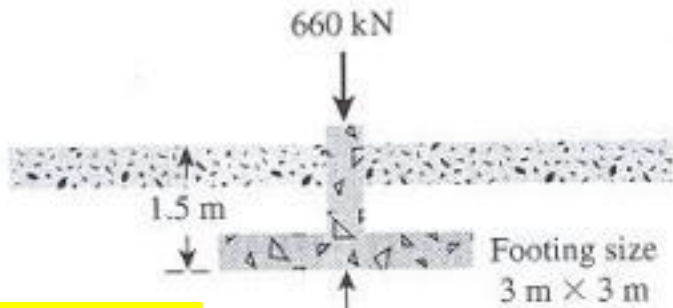

Side View

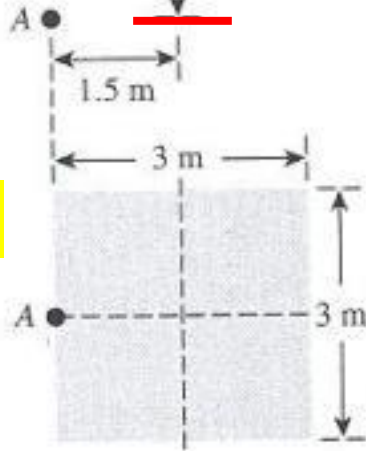

Top View

3 m → 25 mm

$$\Delta\sigma_z = (IV) q M = 0.005 \left(\frac{660}{3 \times 3} \right) 48.5 = \underline{17.78 \text{ kN/m}^2}$$

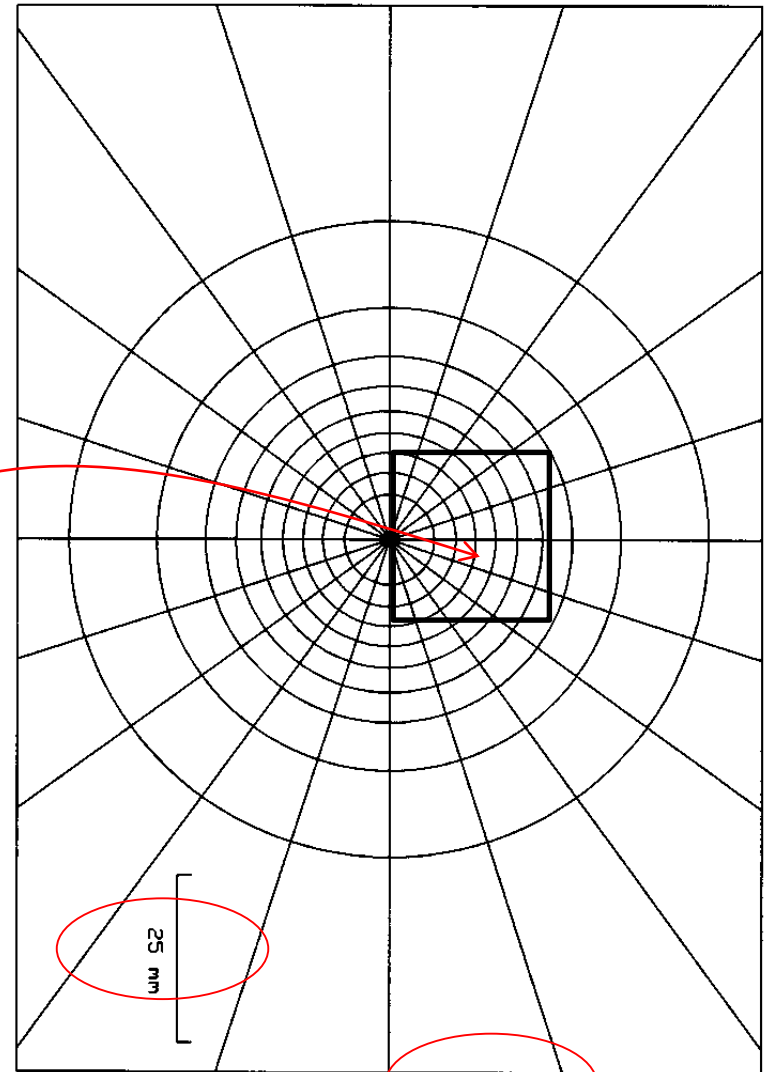

EXAMPLE

A rectangular footing is **3 m X 5 m** and transmits a uniform load of **100 kPa** into the soil mass. Compute the incremental vertical pressures at:

- ⊙ **Point A** which is directly below the **center** of the footing
- ⊙ **Point B** Below the **corner** of the footing
- ⊙ **Point C** which is along the longest axis of the footing **offset by 1.5 m** from the nearest edge.

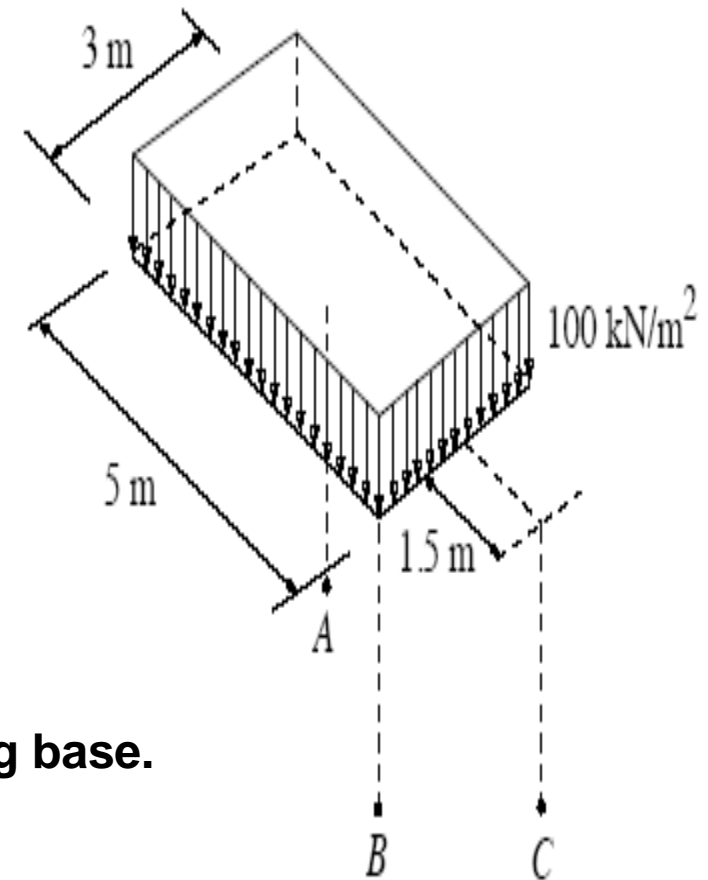

All points are **2.5 m** deep relative to the footing base.

Solution

Let $AB = 2.5$ meters; sketch footing plans in the Newmark chart attached. For point A , use rectangle 1; $n = 107.5$ (verify); $\Delta p = 107.5 \times 0.005 \times 100 = 53.8 \text{ kN/m}^2$. For point B , use rectangle 2; $n = 42.0$ (verify); $\Delta p = 42.0 \times 0.005 \times 100 = 21.0 \text{ kN/m}^2$. For point C , use rectangle 3 (dashed); $n = 20.2$ (verify); $\Delta p = 20.2 \times 0.005 \times 100 = 10.1 \text{ kN/m}^2$.

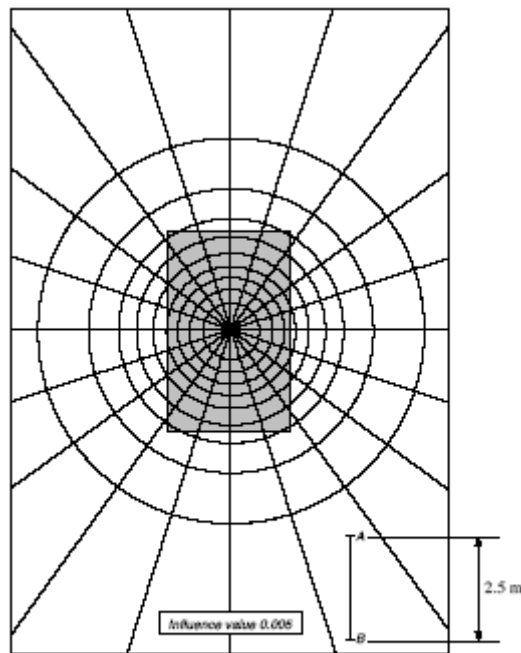

Case A

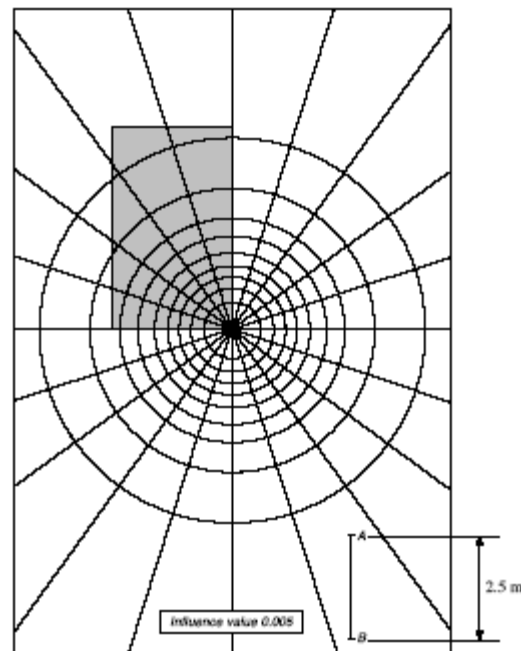

Case B

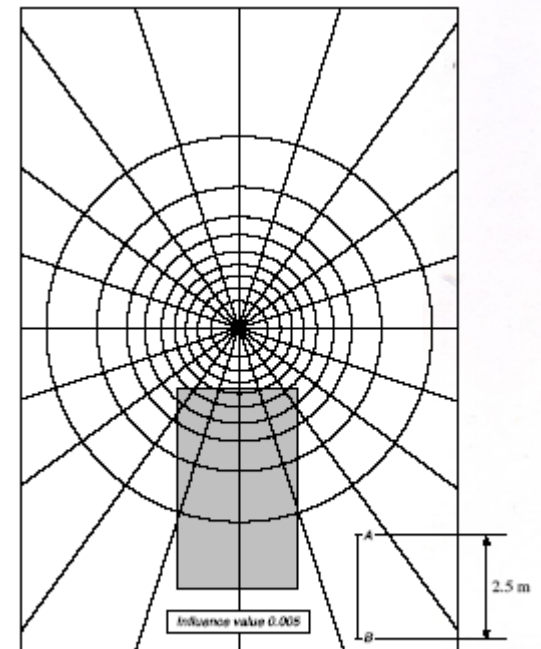

Case C

EXAMPLE

A raft foundation of the size given below carries a uniformly distributed load of 300 kN/m^3 . Estimate the vertical pressure at a depth 9 m below point O marked in the figure.

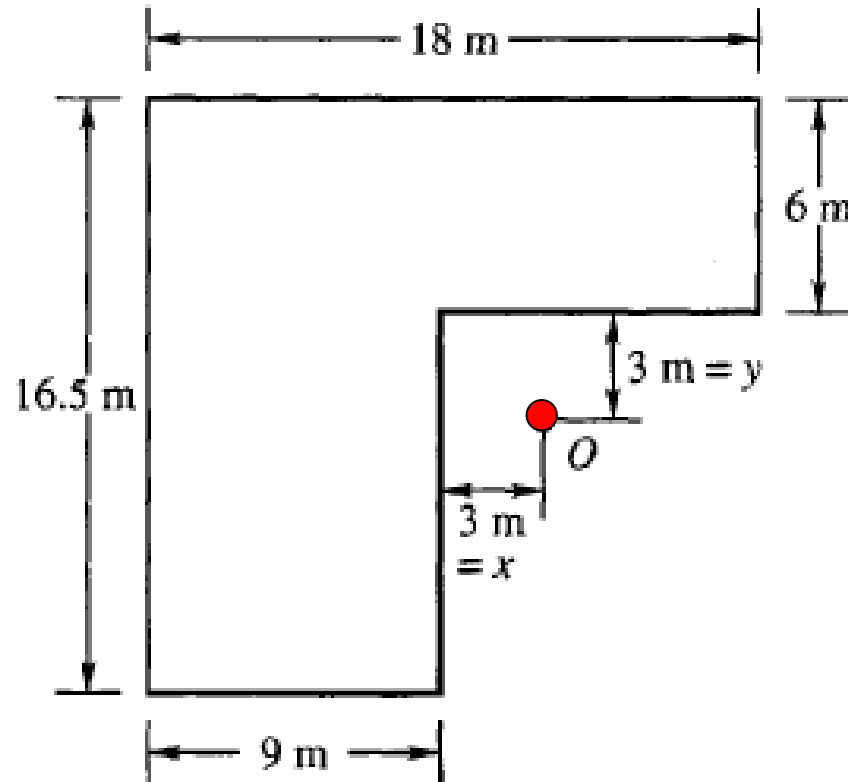

EXAMPLE

Approach 1: Superposition

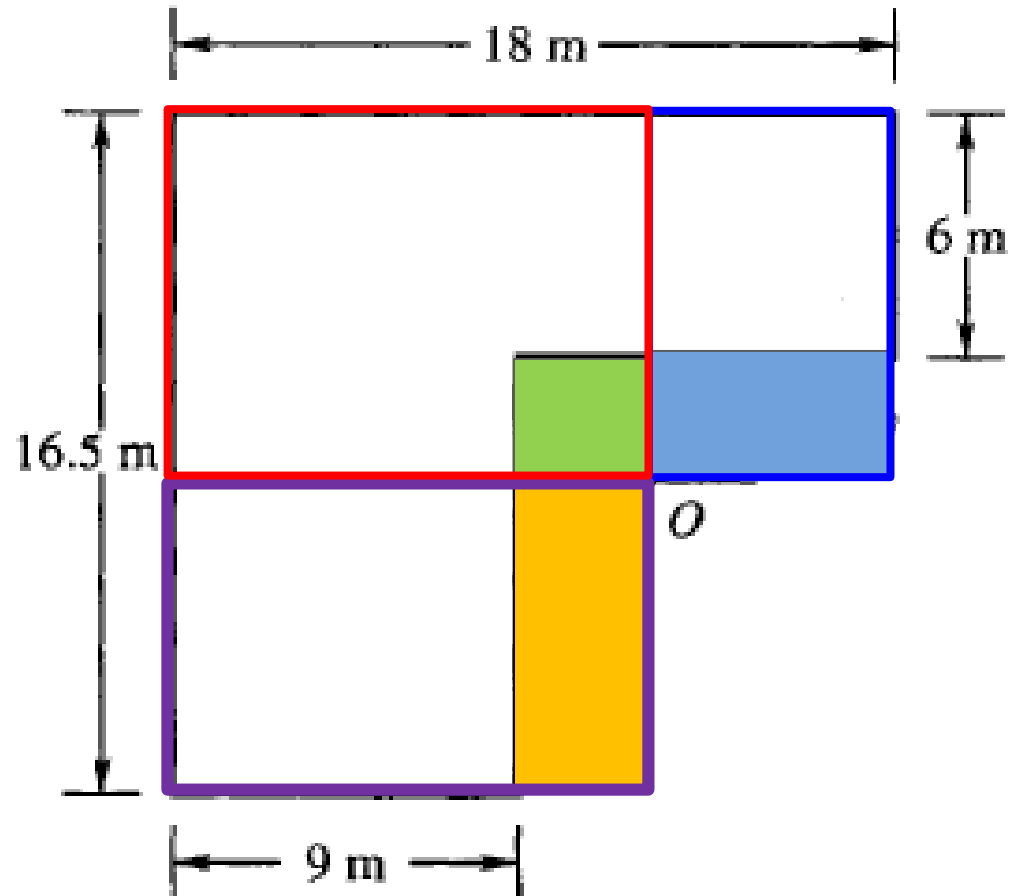

EXAMPLE

Approach 2: Using Newmark's chart

- The Depth at which $\Delta\sigma$ required is **9 m**
- From the Fig. across, the scale of the foundation plan is **AB = 3 cm = 9 m** or **1 cm = 3 m**.
- Plot the loaded area at this scale.
- Superimpose the plan on the chart with point **O** coinciding with the center of the chart.
- Number of loaded blocks occupied by the plan, **M = 62**
- The vertical stress is given by:

$$\Delta\sigma = (IV) \times M \times q$$

$$\Delta\sigma = 0.005 \times 62 \times 300 = \underline{93} \text{ kN/m}^2$$

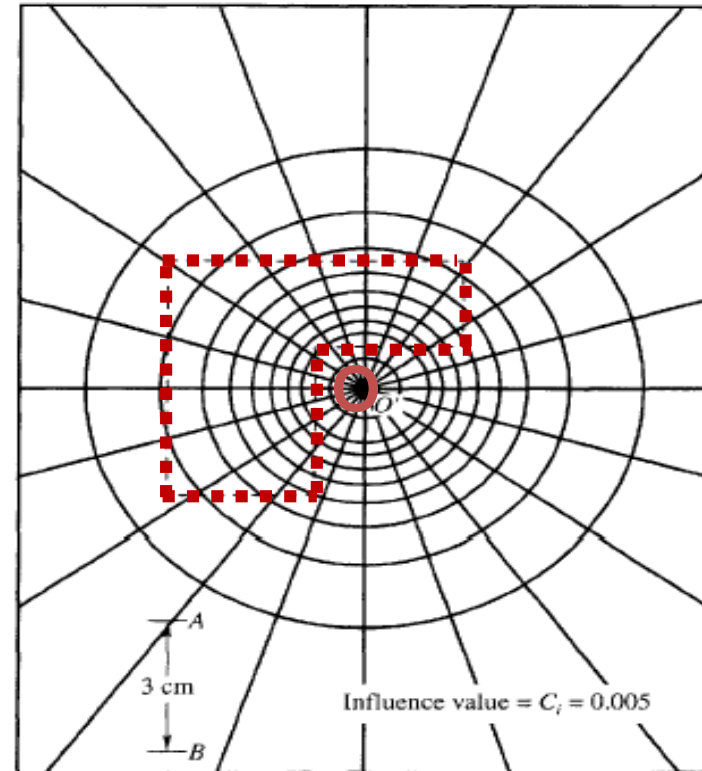

EXAMPLE

- a. For the soil profile shown in Fig. 2a, compute the pore water pressure and effective vertical stress at the mid-depth of layers I, II, and III.
- b. If on top of the soil profile shown in Fig. 2a, the loaded area shown in Fig. 2b is placed at the ground surface level. Compute: -
- The additional vertical stress, $\Delta\sigma_z$, due to the loaded area under point A at the middle of layer I (Use Fadum's method (m & n chart))
 - The additional vertical stress, $\Delta\sigma_z$, due to the loaded area, under point B at the middle of layer II. (Use Newmark's chart).

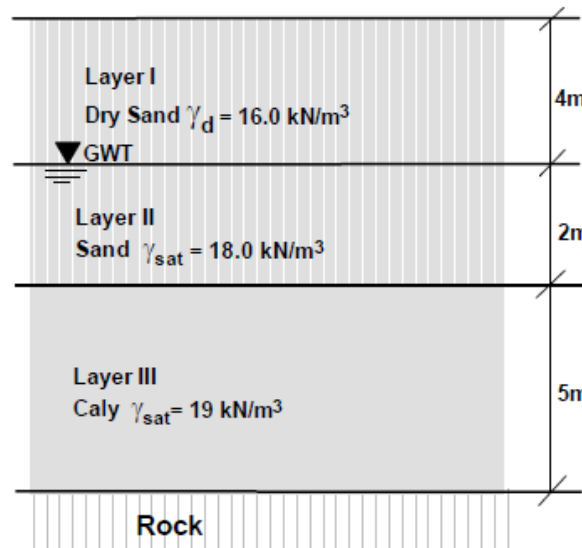

Fig. 2 (a)

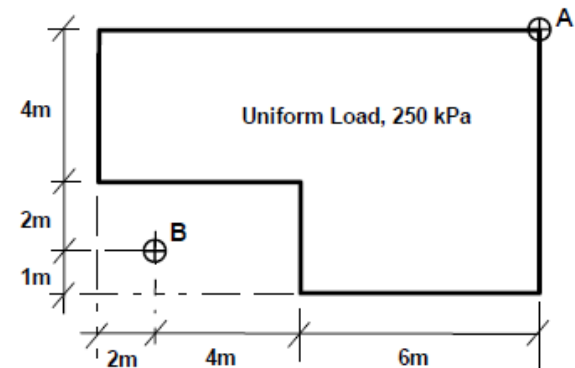

Fig. 2 (b)



THE END