

Chapter 10

MAT FOUNDATIONS

Omitted Sections:

Sections 10.5, 10.6

Types of shallow foundations

1

Spread

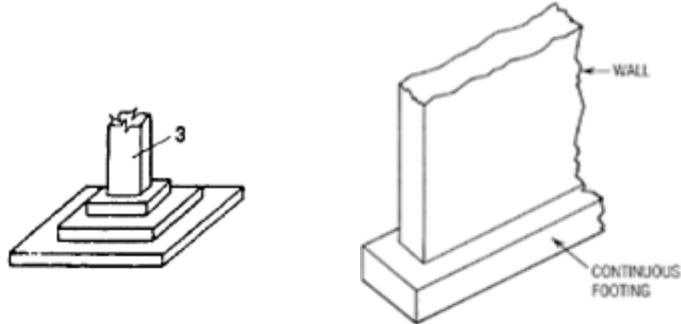

2

Combined

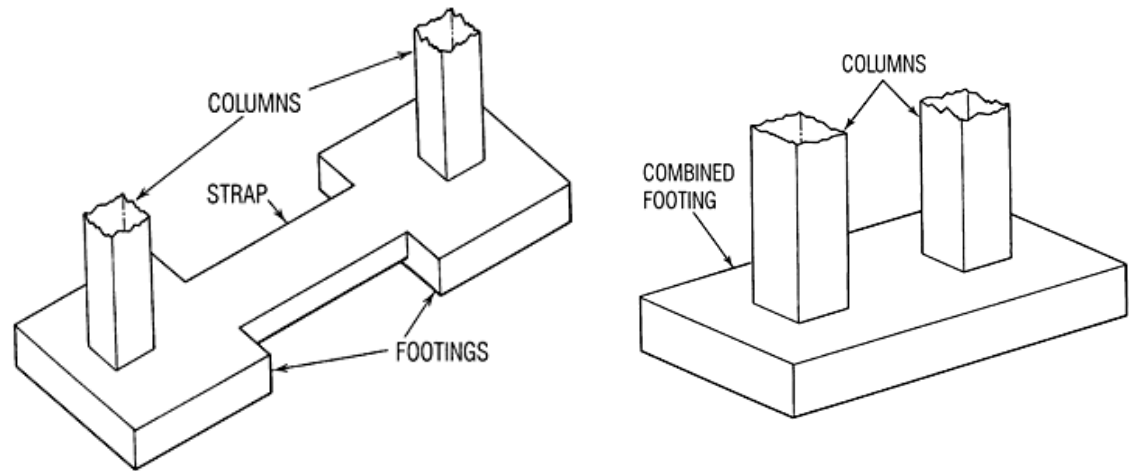

3

Mat (Raft)

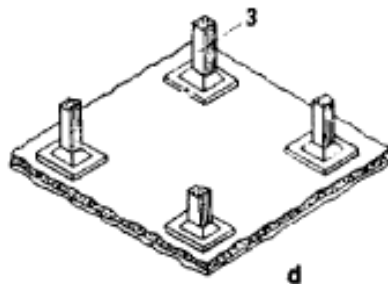

SPREAD FOOTINGS

Pad Foundations

often rectangular or square and are used to support single columns. This is one of the most economical types of footings and is used when columns are spaced at relatively long distances.

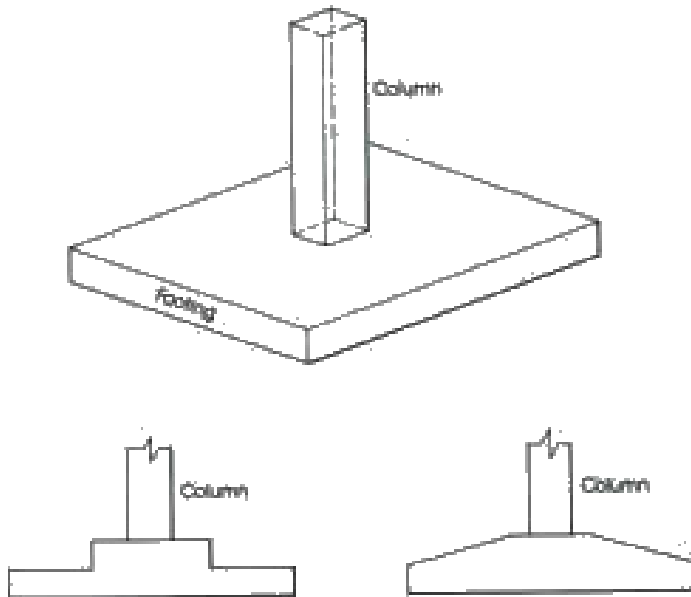

Strip Foundation

Strip footings are **continuous** foundation used to support **walls**.

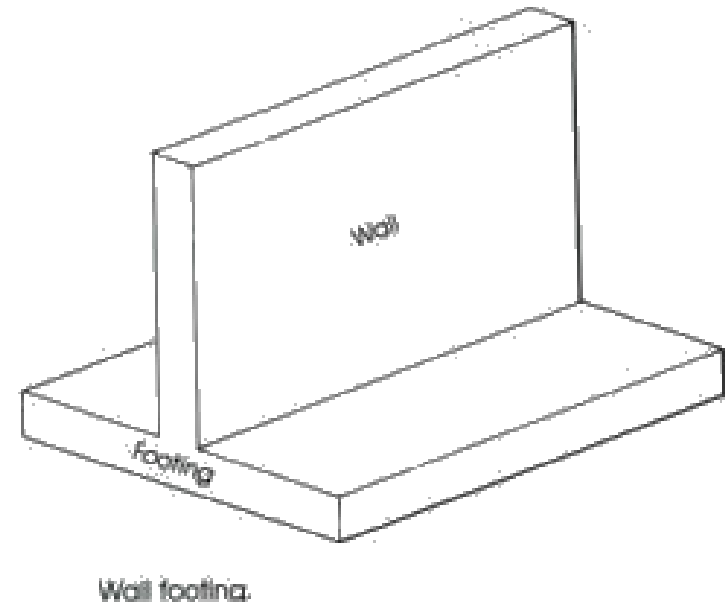

COMBINED FOOTINGS

Combined footings are used when two columns are so close that single footings cannot be used or when one column is located at or near a property.

1. Rectangular Combined Footing

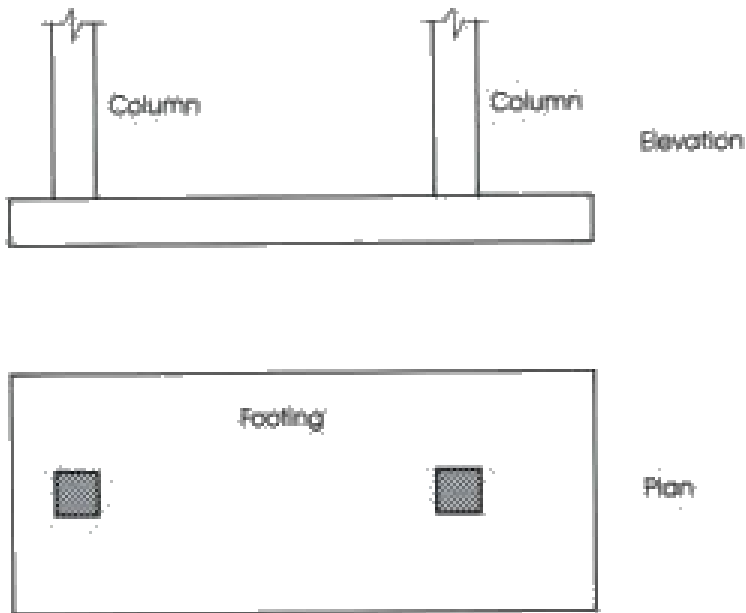

2. Trapezoidal Combined Footing

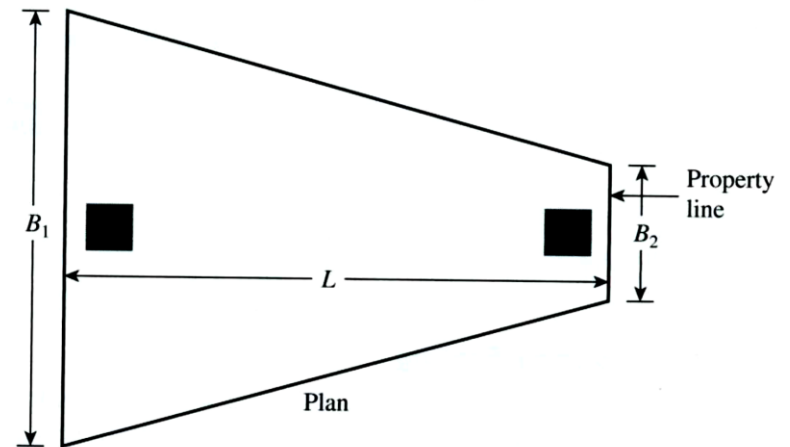

COMBINED FOOTINGS

3. Cantilever Footings

- ❑ Cantilever footing construction uses a *strap beam* to connect an eccentrically loaded column foundation to the foundation of an interior column.
- ❑ Cantilever footings may be used in place of trapezoidal or rectangular combined footings when the allowable soil bearing capacity is high and the distances between the columns are large.
- ❑ It consists of two single footings connected with a **beam** or a strap and support two single columns. This type replaces other combined footings and is more economical.

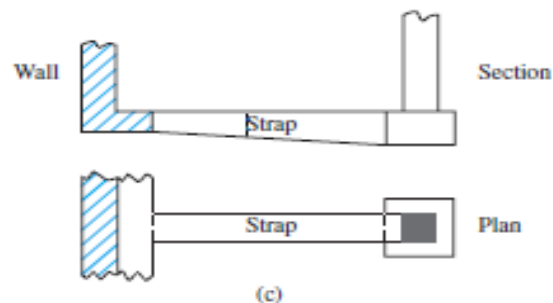
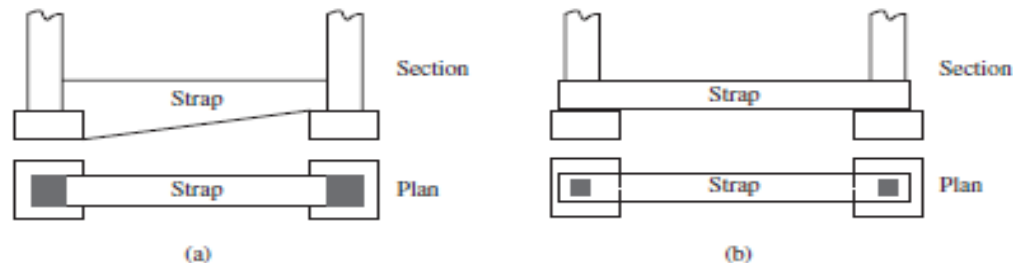

Mat (Raft) Foundations

Mat (Raft) Foundations

Consists of one slab usually placed under the entire building area.

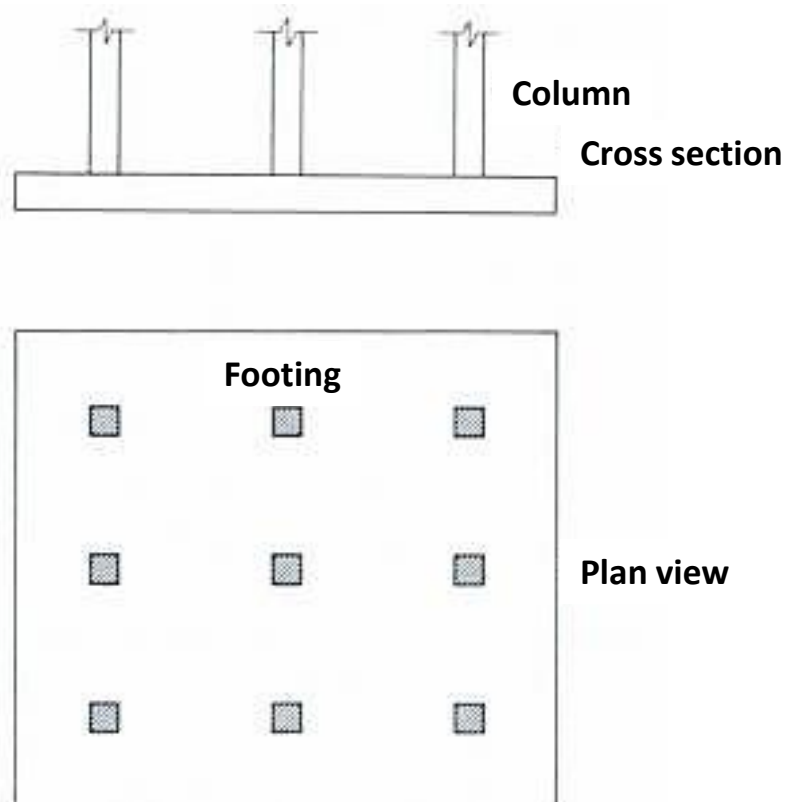

Mat (Raft) Foundations

Mat (Raft) Foundations

Consists of one slab usually placed under the entire building area.



COMBINED FOOTINGS

Combined footings can be classified generally under the following categories:

- Rectangular combined footing
- Trapezoidal combined footing
- Cantilever (strap) footing



RECTANGULAR COMBINED FOOTINGS

RECTANGULAR COMBINED FOOTINGS

There are three cases:

1. Extension is permitted from both side of the footing

To keep the pressure under the foundation uniform, the resultant force of all columns loads (R) must be at the center of the footing, and since the footing is rectangular, R must be at the middle of the footing (at distance $L/2$) from each edge to keep uniform pressure.

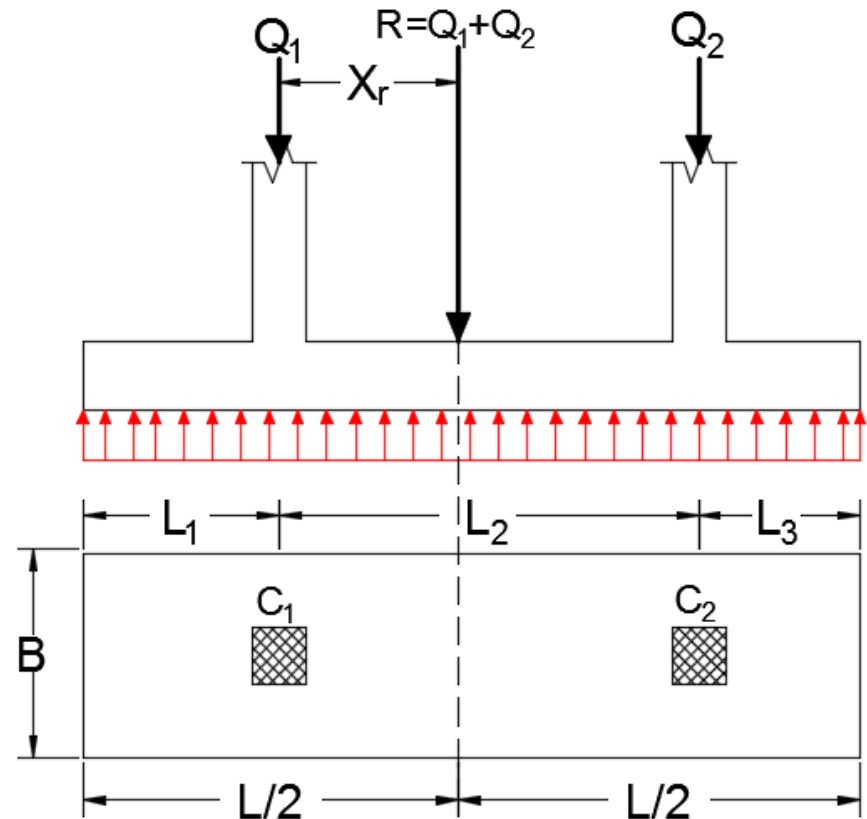

RECTANGULAR COMBINED FOOTINGS

2. Extension is permitted from one side and prevented from other side:

The only difference between this case and case 1 that the extension exists from one side and when we find X we can easily find L :
To keep the pressure uniform
 $X + \text{column width}/2 = L/2$.

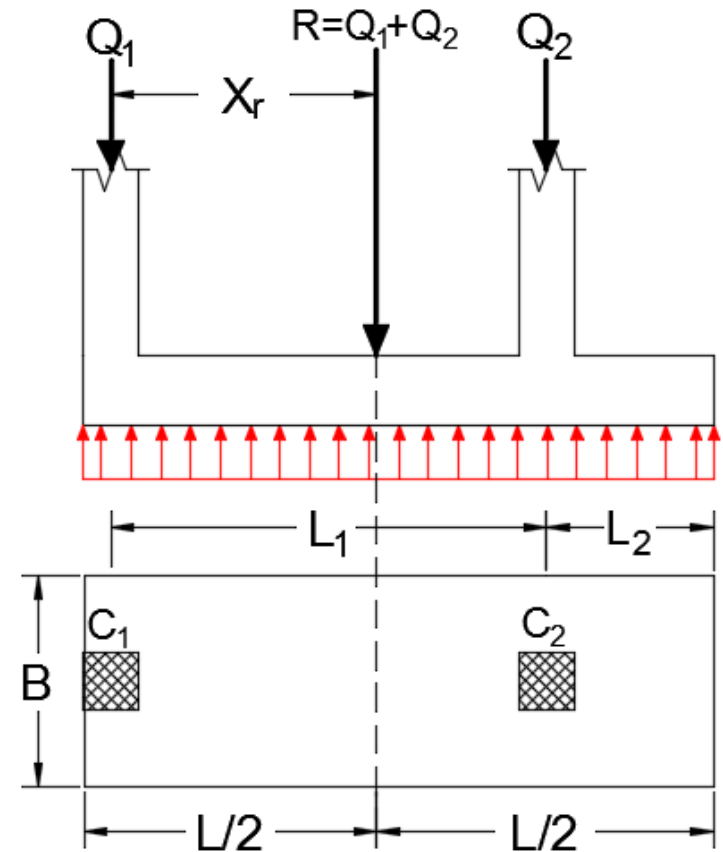

RECTANGULAR COMBINED FOOTINGS

3. Extension is not permitted from both sides of the footing:

In this case the resultant force R is not at the center of rectangular footing because Q_1 and Q_2 are not equals and no extensions from both sides. So the pressure under the foundation is not uniform and we design the footing in this case as following: $L=L_1+W_1+W_2$

How we can find e :

$$\sum M_{\text{foundation center}} = 0.0$$

$$Q_1 \times \left(\frac{L}{2} - \frac{W_1}{2} \right) - Q_2 \times \left(\frac{L}{2} - \frac{W_2}{2} \right) = R \times e$$

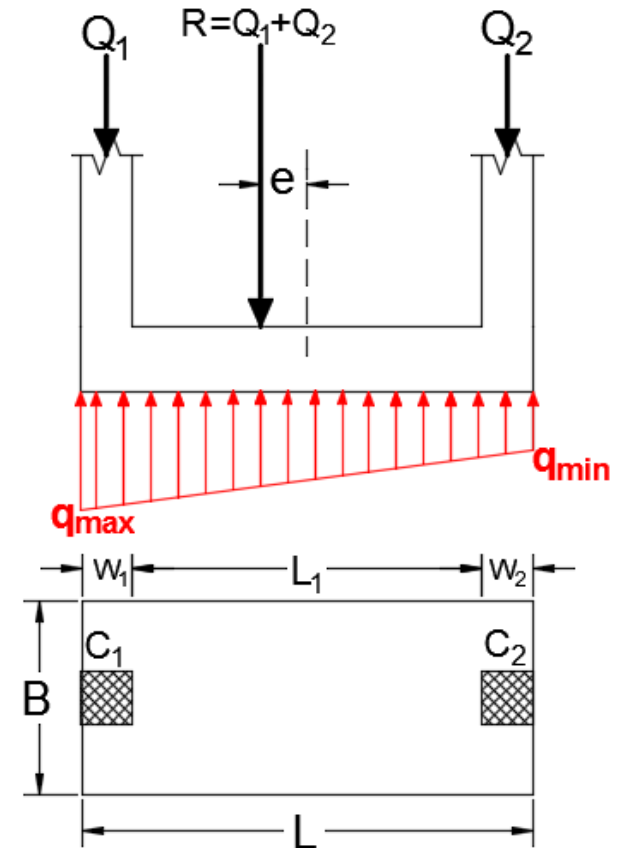

RECTANGULAR COMBINED FOOTINGS

3. Extension is not permitted from both sides of the footing:

The eccentricity in the direction of L:

Usually $e < \frac{L}{6}$ (because L is large)

$$q_{\max} = \frac{R}{B \times L} \left(1 + \frac{6e}{L} \right)$$

$$q_{\text{all,gross}} \geq q_{\max} \rightarrow q_{\text{all,gross}} = q_{\max} \text{ (critical case)}$$

$$q_{\text{all,gross}} = \frac{R}{B \times L} \left(1 + \frac{6e}{L} \right) \rightarrow B = \checkmark.$$

Check for B:

$$q_{\min} = \frac{R}{B \times L} \left(1 - \frac{6e}{L} \right) \text{ must be } \geq 0.0$$

If this condition doesn't satisfied, use the modified equation for q_{\max} to find B:

$$q_{\max,\text{modified}} = \frac{4R}{3B(L - 2e)} \rightarrow B = \checkmark.$$

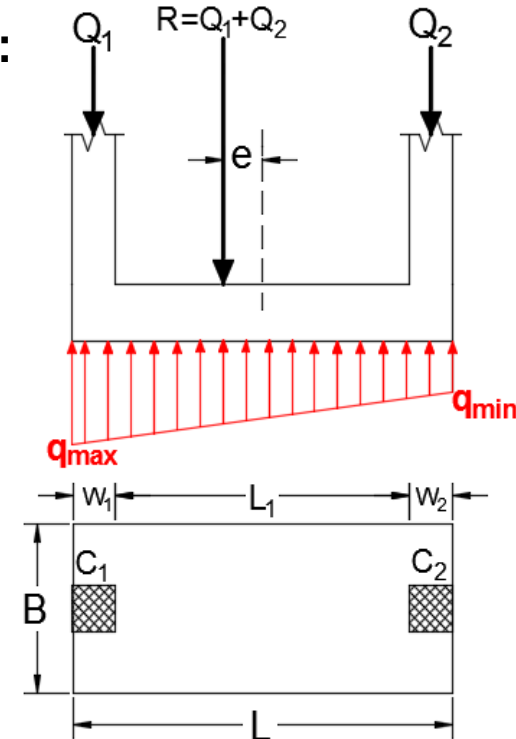

RECTANGULAR COMBINED FOOTINGS

- a. Determine the area of the foundation

$$A = \frac{Q_1 + Q_2}{q_{\text{all(net)}}} \quad (10.1)$$

where

Q_1, Q_2 = column loads

$q_{\text{all(net)}}$ = net allowable soil bearing capacity

- b. Determine the location of the resultant of the column loads. From Figure 10.1,

$$X = \frac{Q_2 L_3}{Q_1 + Q_2} \quad (10.2)$$

- c. For a uniform distribution of soil pressure under the foundation, the resultant of the column loads should pass through the centroid of the foundation. Thus,

$$L = 2(L_2 + X) \quad (10.3)$$

where L = length of the foundation.

- d. Once the length L is determined, the value of L_1 can be obtained as follows:

$$L_1 = L - L_2 - L_3 \quad (10.4)$$

Note that the magnitude of L_2 will be known and depends on the location of the property line.

- e. The width of the foundation is then

$$B = \frac{A}{L} \quad (10.5)$$

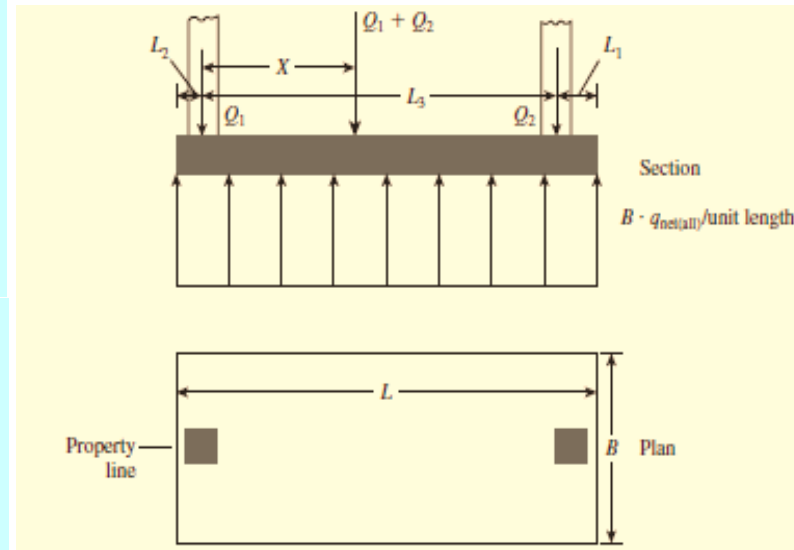

If L as computed in Eq. (10.3) is less than $L_2 + L_3$, it should be increased to encompass the two columns. Here, the resultant is not acting on the centroid of the base anymore, and the pressure distribution becomes nonuniform.

EXAMPLE 10.1

EXAMPLE 10.1

Refer to Figure 10.1. Given:

$$Q_1 = 400 \text{ kN}$$

$$Q_2 = 500 \text{ kN}$$

$$q_{\text{all(net)}} = 140 \text{ kN/m}^2$$

$$L_3 = 3.5 \text{ m}$$

Based on the location of the property line, it is required that L_2 be 1.5 m. Determine the size ($B \times L$) of the rectangular combined footing.

SOLUTION

Area of the foundation required is

$$A = \frac{Q_1 + Q_2}{q_{\text{all(net)}}} = \frac{400 + 500}{140} = 6.43 \text{ m}^2$$

Location of the resultant [Eq. (10.2)] is

$$X = \frac{Q_2 L_3}{Q_1 + Q_2} = \frac{(500)(3.5)}{400 + 500} \approx 1.95 \text{ m}$$

For uniform distribution of soil pressure under the foundation from Eq. (10.3), we have

$$L = 2(L_2 + X) = 2(1.5 + 1.95) = \mathbf{6.9 \text{ m}}$$

Again, from Eq. (10.4),

$$L_1 = L - L_2 - L_3 = 6.9 - 1.5 - 3.5 = 1.9 \text{ m}$$

Thus,

$$B = \frac{A}{L} = \frac{6.43}{6.9} = \mathbf{0.93 \text{ m}}$$

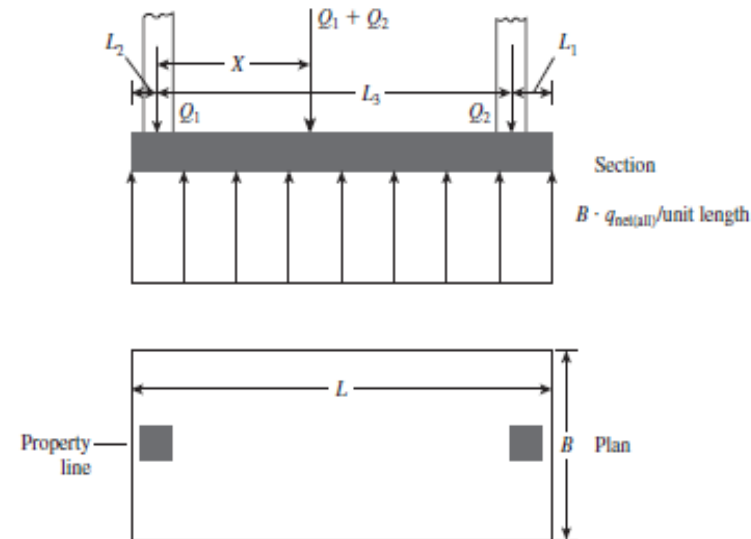



TRAPEZOIDAL COMBINED FOOTINGS

TRAPEZOIDAL COMBINED FOOTINGS

Advantages:

1. More economical than rectangular combined footing in case of “extension is not permitted from both sides” especially if there is a large difference between columns loads.
2. To keep uniform contact pressure in case of “extension is not permitted from both sides”, use trapezoidal footing because the resultant force “R” can be located at the centroid of trapezoidal footing.

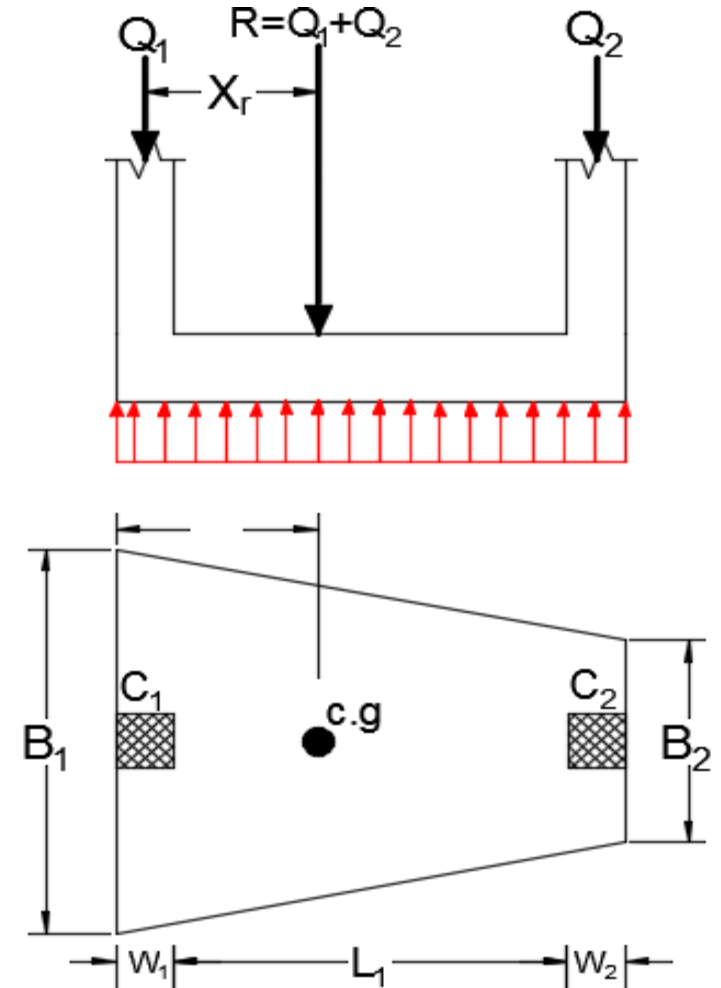

TRAPEZOIDAL COMBINED FOOTINGS

- a. If the net allowable soil pressure is known, determine the area of the foundation:

$$A = \frac{Q_1 + Q_2}{q_{\text{all(net)}}} \quad (10.6)$$

From Figure 10.2,

$$A = \frac{B_1 + B_2}{2} L \quad (10.7)$$

- b. Determine the location of the resultant for the column loads:

$$X = \frac{Q_2 L_3}{Q_1 + Q_2} \quad (10.8)$$

- c. From the property of a trapezoid, where the resultant column load passes through the centroid,

$$X + L_2 = \left(\frac{B_1 + 2B_2}{B_1 + B_2} \right) \frac{L}{3} \quad (10.9)$$

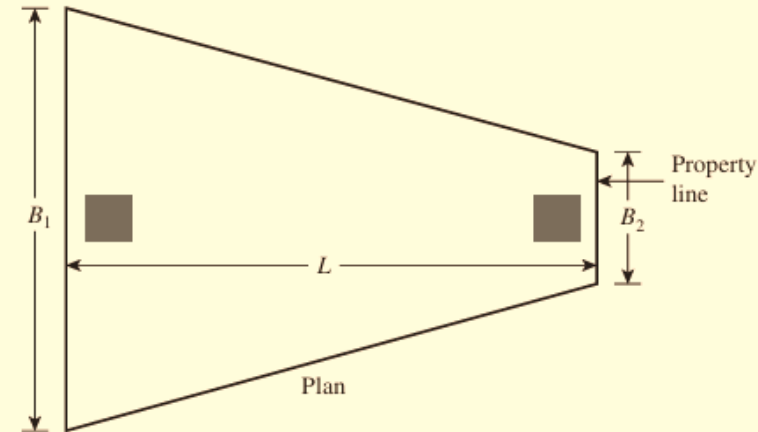
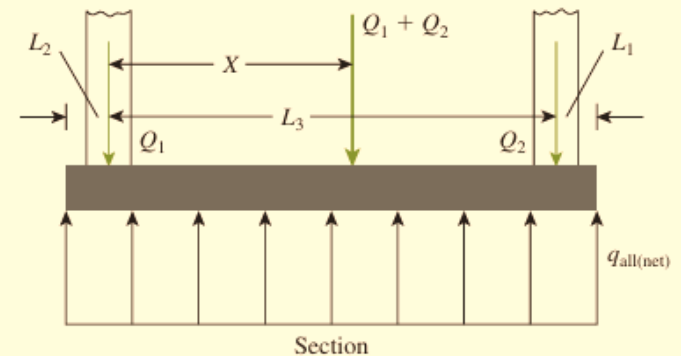

With known values of A , L , X , and L_2 , Eqs. (10.7) and (10.9) can be solved to obtain B_1 and B_2 . Note that, for a trapezoid,

$$\frac{L}{3} < X + L_2 < \frac{L}{2}$$

EXAMPLE 10.2

EXAMPLE 10.2

Refer to Figure 10.2. Given:

$$Q_1 = 1000 \text{ kN}$$

$$Q_2 = 400 \text{ kN}$$

$$L_3 = 3 \text{ m}$$

$$q_{\text{all}(\text{net})} = 120 \text{ kN/m}^2$$

Based on the space available for construction, it is required that $L_2 = 1.2 \text{ m}$ and $L_1 = 1 \text{ m}$. Determine B_1 and B_2 .

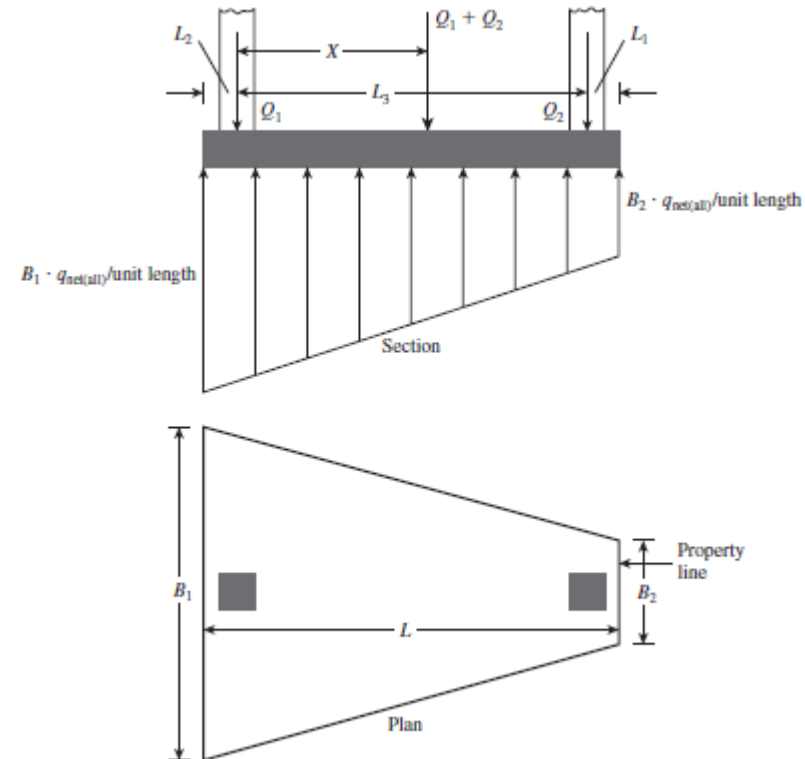

EXAMPLE 10.2

SOLUTION

The area of the trapezoidal combined footing required is [Eq. (10.6)]

$$A = \frac{Q_1 + Q_2}{Q_{\text{all(net)}}} = \frac{1000 + 400}{120} = 11.67 \text{ m}^2$$

$$L = L_1 + L_2 + L_3 = 1 + 1.2 + 3 = 5.2 \text{ m}$$

From Eq. (10.7),

$$A = \frac{B_1 + B_2}{2} L$$

$$11.67 = \left(\frac{B_1 + B_2}{2} \right) (5.2)$$

or

$$B_1 + B_2 = 4.49 \text{ m} \quad (\text{a})$$

From Eq. (10.8),

$$X = \frac{Q_2 L_3}{Q_1 + Q_2} = \frac{(400)(3)}{1000 + 400} = 0.857 \text{ m}$$

Again, from Eq. (10.9),

$$X + L_2 = \left(\frac{B_1 + 2B_2}{B_1 + B_2} \right) \frac{L}{3}$$

$$0.857 + 1.2 = \left(\frac{B_1 + 2B_2}{B_1 + B_2} \right) \left(\frac{5.2}{3} \right)$$

$$\frac{B_1 + 2B_2}{B_1 + B_2} = 1.187 \quad (\text{b})$$

From Eqs. (a) and (b), we have

$$B_1 = 3.65 \text{ m}$$

$$B_2 = 0.84 \text{ m}$$



CANTILEVER FOOTINGS

CANTILEVER FOOTINGS

1. Used when there is a **property line** which prevents the footing to be extended beyond the face of the edge column. In addition to that the edge column is relatively far from the interior column so that the rectangular and trapezoidal combined footings will be **too narrow and long which increases the cost**.
2. May be used to connect two interior foundations, one foundation has a large load require a large area but this area not available, and the other foundation has a small load and there is available area to enlarge this footing, so a strap beam is used to connect these two foundations to transfer the load from the largest to the smallest foundation.
3. There is a “strap beam” which connects two separated footings. The edge footing is usually eccentrically loaded and the interior footing is centrically loaded. **The purpose of the beam is to prevent overturning of the eccentrically loaded footing and to keep uniform pressure under this foundation.**
4. The strap beam doesn't touch the ground (i.e. there is no contact between the strap beam and the soil, so no bearing pressure applied on it).
5. This footing also called **“cantilever footing”** because the overall moment on the strap beam is negative moment.

CANTILEVER FOOTINGS

- ❑ Cantilever footing construction uses a *strap beam* to connect an eccentrically loaded column foundation to the foundation of an interior column.
- ❑ Cantilever footings may be used in place of trapezoidal or rectangular combined footings when the allowable soil bearing capacity is high and the distances between the columns are large.
- ❑ It consists of two single footings connected with a **beam** or a strap and support two single columns. This type replaces other combined footings and is more economical.

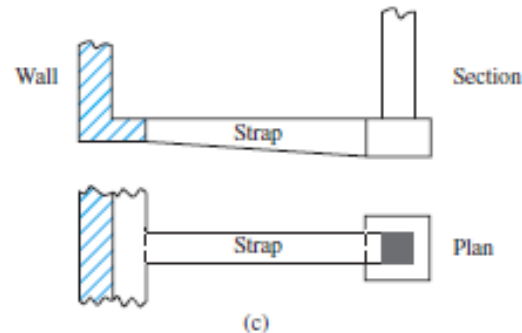
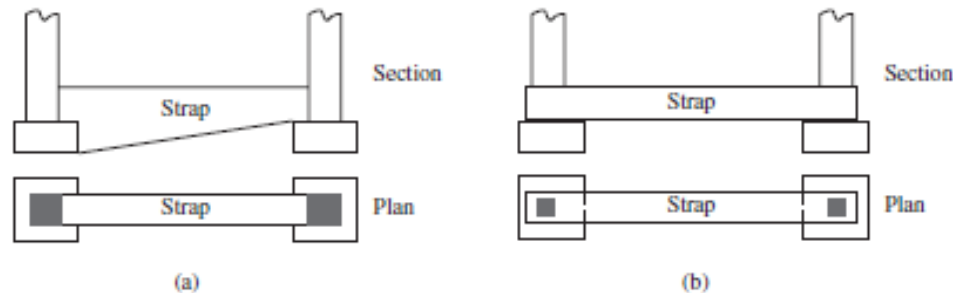

REMARKS

$$x = \frac{L}{3} \left(\frac{B_1 + 2B_2}{B_1 + B_2} \right)$$

iF $x = \frac{L}{2}$ **Rectangular Combined Footing**

iF $\frac{L}{3} < x < \frac{L}{2}$ **Trapezoidal Shape Footing**

iF $x = \frac{L}{3}$ **Triangle $B_2 = 0$**
 $x = L/2$ if $B_1 = B_2$

iF $x < \frac{L}{3}$ **No Solution Exists (B_2 -ve)**

WHICH TYPE OF COMBINED FOOTING

Choice of Combined-Rectangular

- ❑ If doubling the centroid distance will provide sufficient length to reach the interior column.

Choice of Combined-Trapezoidal

- ❑ A combined footing will be trapezoid-shaped if the column that has too limited a space for a spread footing carries the larger load.
- ❑ In this case the resultant of the column loads (including moments) will be closer to the larger column load, and doubling the centroid distance as done for the rectangular footing will not provide sufficient length to reach the interior column.

WHICH TYPE OF COMBINED FOOTING

Choice of Strap

- The strap footing may be used in lieu of a combined rectangular or trapezoid footing if the distance between columns is large and/or the allowable soil pressure is relatively large so that the additional footing area is not needed.
- A strap footing should be considered only after a careful analysis shows that spread footings—even if oversize—will not work.
- The extra labor and forming costs for this type of footing make it one to use as a last resort.

WHICH TYPE OF COMBINED FOOTING

Combined vs. Strap

- ❑ The choice between strap and combined depends primarily upon the relative cost. As a rule the strap footing is more economical than the combined footing where the subsoil has large bearing capacity. However, if the required strap becomes large and deep, the combined footing may be less expensive.



MAT FOUNDATIONS

MAT FOUNDATIONS

Mat foundation is used in the following cases:

1. If the area of isolated and combined footing $> 50\%$ of the structure area, because this means the loads are very large and the bearing capacity of the soil is relatively small.
2. If the bearing capacity of the soil is small.
3. If the soil supporting the structure classified as (bad soils) such as:
 - ✓ **Expansive Soil:** Expansive soils are characterized by clayey material that shrinks and swells as it dries or becomes wet respectively. It is recognized from high values of Plasticity Index, Plastic Limit and Shrinkage Limit.
 - ✓ **Compressible soil:** It contains a high content of organic material and not exposed to great pressure during its geological history, so it will be exposed to a significant settlement, so mat foundation is used to avoid differential settlement.
 - ✓ **Collapsible soil:** Collapsible soils are those that appear to be strong and stable in their natural (dry) state, but they rapidly consolidate under wetting, generating large and often unexpected settlements. This can yield disastrous consequences for structures built on such deposits.

Common Types of Mat Foundations

Several types of mat foundations are used currently. Some of the common ones are:

- Flat plate. The mat is of uniform thickness.**
- Flat plate thickened under columns.**
- Beams and slab. The beams run both ways, and the columns are located at the intersection of the beams.**
- Flat plates with pedestals.**
- Slab with basement walls as a part of the mat. The walls act as stiffeners for the mat.**

Common Types of Mat Foundations

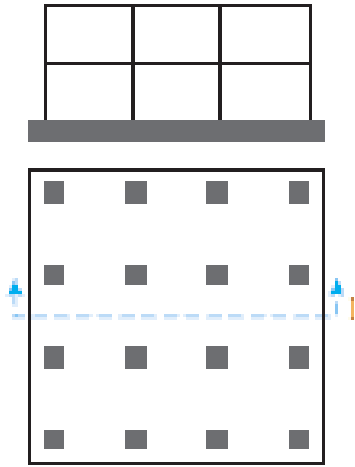

Flat plate of uniform thickness

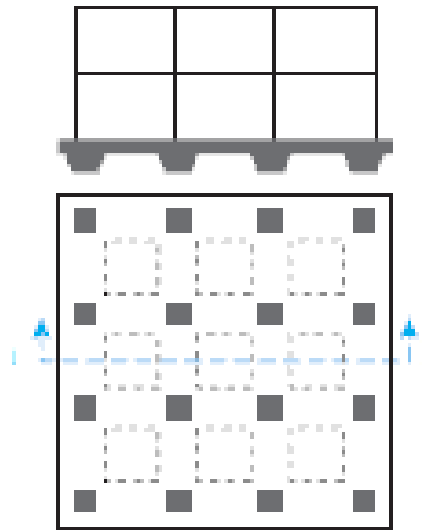

Beams and slab

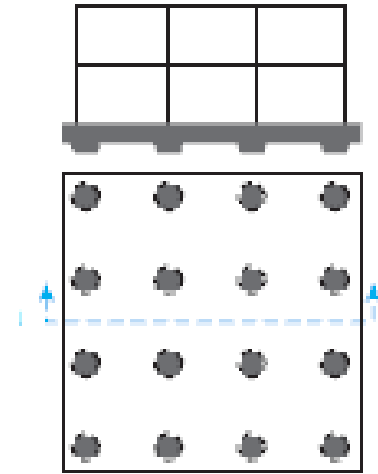

Flat plate thickened under columns

Common Types of Mat Foundations

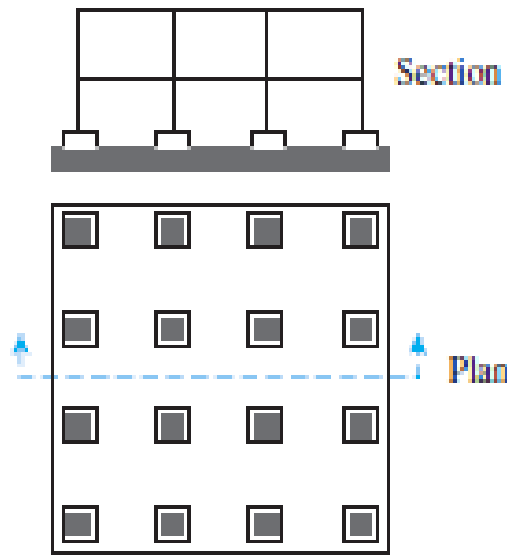

Flat plates with pedestals

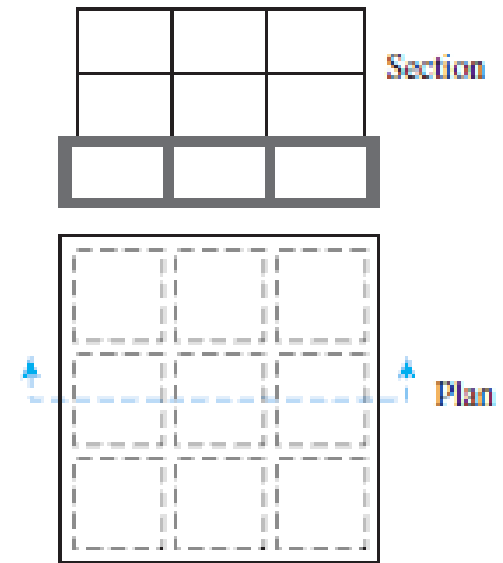

Slab with basement walls

Common Types of Mat Foundations

Mats may be supported by piles, which help reduce the settlement of a structure built over highly compressible soil. Where the water table is high, mats are often placed over piles to control buoyancy.

Figure shows the difference between the depth D_f and the width B of isolated foundations and mat foundations..

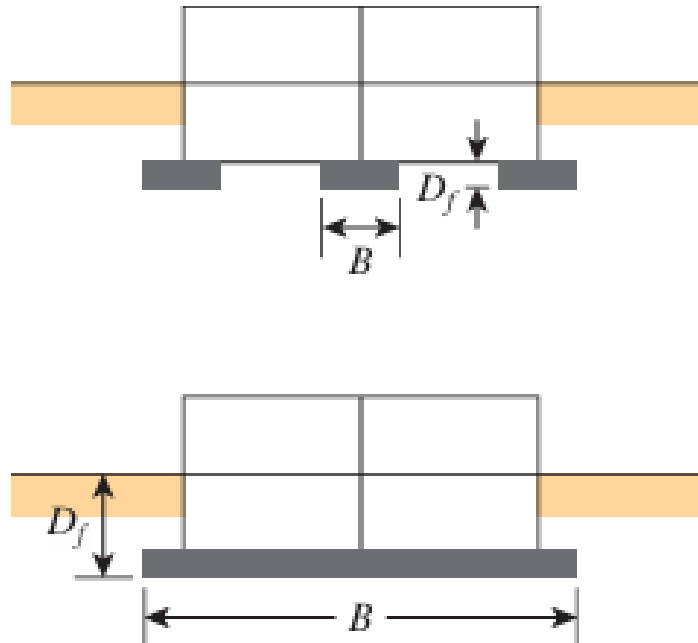

FLAT-PLATE MAT FOUNDATION

Flat-plate mat foundation under construction



Bearing Capacity of Mat Foundations

The *gross ultimate bearing capacity* of a mat foundation can be determined by

$$q_u = c'N_cF_{cs}F_{cd}F_{ci} + qN_qF_{qs}F_{qd}F_{qi} + \frac{1}{2}\gamma BN_\gamma F_{\gamma s}F_{\gamma d}F_{\gamma i}$$

The *net ultimate capacity* of a mat foundation

$$q_{net(u)} = q_u - q$$

Saturated clays with $\phi=0$

$$q_u = c_u N_c F_{cs} F_{cd} + q$$

where c_u = undrained cohesion. (Note: $N_c = 5.14$, $N_q = 1$, and $N_\gamma = 0$)
From Table 4.3, for $\phi = 0$,

$$F_{cs} = 1 + \frac{B}{L} \left(\frac{N_q}{N_c} \right) = 1 + \left(\frac{B}{L} \right) \left(\frac{1}{5.14} \right) = 1 + \frac{0.195B}{L}$$

and

$$F_{cd} = 1 + 0.4 \left(\frac{D_f}{B} \right)$$

Substitution of the preceding shape and depth factors into Eq. (8.10) yields

$$q_u = 5.14 c_u \left(1 + \frac{0.195B}{L} \right) \left(1 + 0.4 \frac{D_f}{B} \right) + q$$

Hence, the net ultimate bearing capacity is

$$q_{\text{net}(u)} = q_u - q = 5.14 c_u \left(1 + \frac{0.195B}{L} \right) \left(1 + 0.4 \frac{D_f}{B} \right)$$

For FS = 3, the net allowable soil bearing capacity becomes

$$q_{\text{net}(\text{all})} = \frac{q_{\text{net}(u)}}{\text{FS}} = 1.713 c_u \left(1 + \frac{0.195B}{L} \right) \left(1 + 0.4 \frac{D_f}{B} \right)$$

Granular soils (c=0)

$$q_{\text{net}}(\text{kN/m}^2) = \frac{N_{60}}{0.08} \left(\frac{B + 0.3}{B} \right)^2 F_d \left(\frac{S_e}{25} \right)$$

where

N_{60} = standard penetration resistance

B = width (m)

$F_d = 1 + 0.33(D_f/B) \leq 1.33$

S_e = settlement, (mm)

When the width B is large, assuming $D_f/B = 1$, the preceding equation can be approximated as

$$\begin{aligned} q_{\text{net}}(\text{kN/m}^2) &= \frac{N_{60}}{0.08} F_d \left(\frac{S_e}{25} \right) \\ &= \frac{N_{60}}{0.08} \left[1 + 0.33 \left(\frac{D_f}{B} \right) \right] \left[\frac{S_e(\text{mm})}{25} \right] \\ &\leq 0.67 N_{60} [S_e(\text{mm})] \end{aligned}$$

Hence the maximum value of q_{net} can be given

$$q_{\text{max(net)}} (\text{kN/m}^2) = 0.67 N_{60} [S_e(\text{mm})]$$

Net pressure on soil caused by a mat foundation

$$q = \frac{Q}{A} - \gamma D_f$$

where

Q = dead weight of the structure and the live load

A = area of the raft

In all cases, q should be less than or equal to allowable $q_{\text{net(all)}}$.

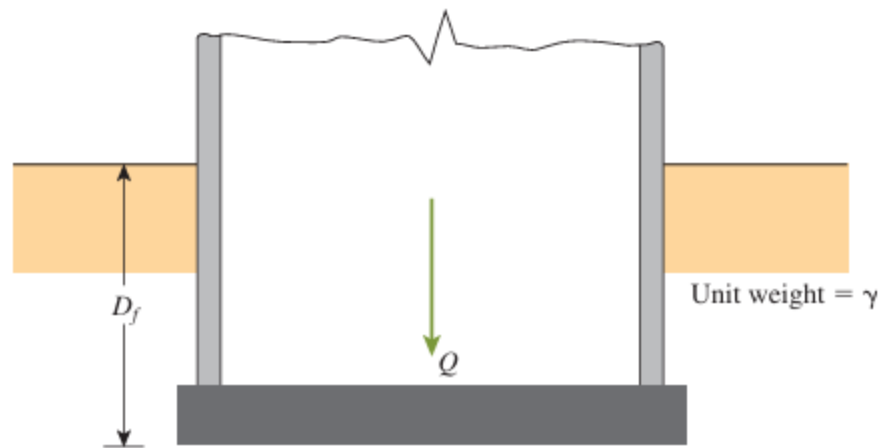

FIGURE 10.7 Definition of net pressure on soil caused by a mat foundation

EXAMPLE 10.3

EXAMPLE 10.3

Determine the net ultimate bearing capacity of a mat foundation measuring $20 \text{ m} \times 8 \text{ m}$ on a saturated clay with $c_u = 85 \text{ kN/m}^2$, $\phi = 0$, and $D_f = 1.5 \text{ m}$.

SOLUTION

From Eq. (10.12),

$$\begin{aligned} q_{u(\text{net})} &= 5.14c_u \left[1 + \left(\frac{0.195B}{L} \right) \right] \left[1 + 0.4 \frac{D_f}{B} \right] \\ &= (5.14)(85) \left[1 + \left(\frac{0.195 \times 8}{20} \right) \right] \left[1 + \left(\frac{0.4 \times 1.5}{8} \right) \right] \\ &= \mathbf{506.3 \text{ kN/m}^2} \end{aligned}$$

EXAMPLE 10.4

EXAMPLE 10.4

What will be the net allowable bearing capacity of a mat foundation with dimensions of $13.7 \text{ m} \times 9.15 \text{ m}$ constructed over a sand deposit? Here, $D_f = 1.98 \text{ m}$, the allowable settlement is 50 mm , and the average penetration number $N_{60} = 10$.

SOLUTION

From Eq. (10.14),

$$q_{\text{all(net)}} = \frac{N_{60}}{0.08} \left[1 + 0.33 \left(\frac{D_f}{B} \right) \right] \left(\frac{S_e}{25} \right)$$

or

$$q_{\text{all(net)}} = \frac{10}{0.08} \left[1 + \frac{0.33 \times 1.98}{9.15} \right] \left(\frac{50}{25} \right) = \mathbf{267.85 \text{ kN/m}^2}$$

Compensated Foundation

Net average applied pressure on soil is

$$q = \frac{Q}{A} - \gamma D_f$$

For no increase in the net pressure on soil below a mat foundation, q should be zero. Thus,

$$D_f = \frac{Q}{A\gamma}$$

D_f = the depth of a fully compensated foundation

$$FS = \frac{q_{net(u)}}{q} = \frac{q_{net(u)}}{\frac{Q}{A} - \gamma D_f}$$

where $q_{net(u)}$ = net ultimate bearing capacity

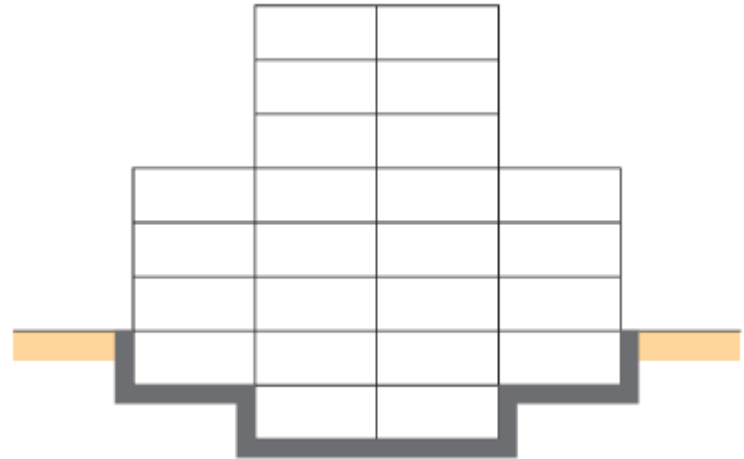

For saturated clays

$$FS = \frac{5.14c_u \left(1 + \frac{0.195B}{L}\right) \left(1 + 0.4 \frac{D_f}{B}\right)}{\frac{Q}{A} - \gamma D_f}$$

EXAMPLE 10.5

EXAMPLE 10.5

The mat shown in Figure 10.7 has dimensions of 20 m \times 30 m. The total dead and live load on the mat is 110 MN. The mat is placed over a saturated clay having a unit weight of 18 kN/m³ and $c_u = 140$ kN/m². Given that $D_f = 1.5$ m, determine the factor of safety against bearing capacity failure.

SOLUTION

From Eq. (10.23), the factor of safety

$$FS = \frac{5.14c_u \left(1 + \frac{0.195B}{L}\right) \left(1 + 0.4 \frac{D_f}{B}\right)}{\frac{Q}{A} - \gamma D_f}$$

We are given that $c_u = 140$ kN/m², $D_f = 1.5$ m, $B = 20$ m, $L = 30$ m, and $\gamma = 18$ kN/m³. Hence,

$$FS = \frac{(5.14)(140) \left[1 + \frac{(0.195)(20)}{30}\right] \left[1 + 0.4 \left(\frac{1.5}{20}\right)\right]}{\left(\frac{110,000 \text{ kN}}{20 \times 30}\right) - (18)(1.5)} = 5.36$$

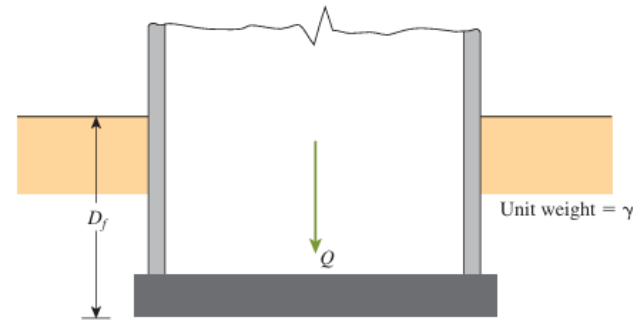

FIGURE 10.7 Definition of net pressure on soil caused by a mat foundation

EXAMPLE 10.6

EXAMPLE 10.6

Consider a mat foundation $30\text{ m} \times 40\text{ m}$ in plan, as shown in Figure 10.9. The total dead load and live load on the raft is $200 \times 10^3\text{ kN}$. Estimate the consolidation settlement at the center of the foundation.

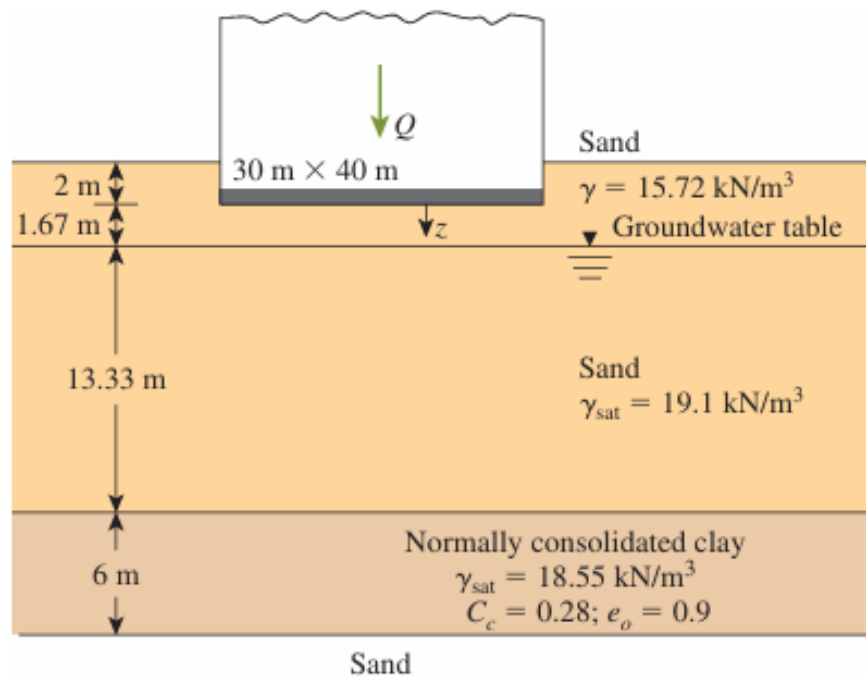

FIGURE 10.9 Consolidation settlement under a mat foundation

EXAMPLE 10.6

SOLUTION

From Eq. (2.65),

$$S_{c(p)} = \frac{C_c H_c}{1 + e_o} \log\left(\frac{\sigma'_o + \Delta\sigma'_{av}}{\sigma'_o}\right)$$

$$\sigma'_o = (3.67)(15.72) + (13.33)(19.1 - 9.81) + \frac{6}{2}(18.55 - 9.81) \approx 208 \text{ kN/m}^2$$

$$H_c = 6 \text{ m}$$

$$C_c = 0.28$$

$$e_o = 0.9$$

For $Q = 200 \times 10^3$ kN, the net load per unit area is

$$q = \frac{Q}{A} - \gamma D_f = \frac{200 \times 10^3}{30 \times 40} - (15.72)(2) \approx 135.2 \text{ kN/m}^2$$

EXAMPLE 10.6

In order to calculate $\Delta\sigma'_{av}$, we refer to Section 8.9. The loaded area can be divided into four areas, each measuring $15\text{ m} \times 20\text{ m}$. Now using Eq. (8.20), we can calculate the average stress increase in the clay layer below the corner of each rectangular area, or

$$\begin{aligned}\Delta\sigma'_{av(H_2/H_1)} &= q_o \left[\frac{H_2 I_{a(H_2)} - H_1 I_{a(H_1)}}{H_2 - H_1} \right] \\ &= 135.2 \left[\frac{(1.67 + 13.33 + 6) I_{a(H_2)} - (1.67 + 13.33) I_{a(H_1)}}{6} \right]\end{aligned}$$

EXAMPLE 10.6

For $I_{a(H_2)}$,

$$m_2 = \frac{B}{H_2} = \frac{15}{1.67 + 13.33 + 6} = 0.71$$

$$n_2 = \frac{L}{H_2} = \frac{20}{21} = 0.95$$

From Figure 8.11, for $m_2 = 0.71$ and $n_2 = 0.95$, the value of $I_{a(H_2)}$ is 0.21. Again, for $I_{a(H_1)}$,

$$m_2 = \frac{B}{H_1} = \frac{15}{15} = 1$$

$$n_2 = \frac{L}{H_1} = \frac{20}{15} = 1.33$$

From Figure 8.11, $I_{a(H_1)} = 0.225$, so

$$\Delta\sigma'_{av(H_2/H_1)} = 135.2 \left[\frac{(21)(0.21) - (15)(0.225)}{6} \right] = 23.32 \text{ kN/m}^2$$

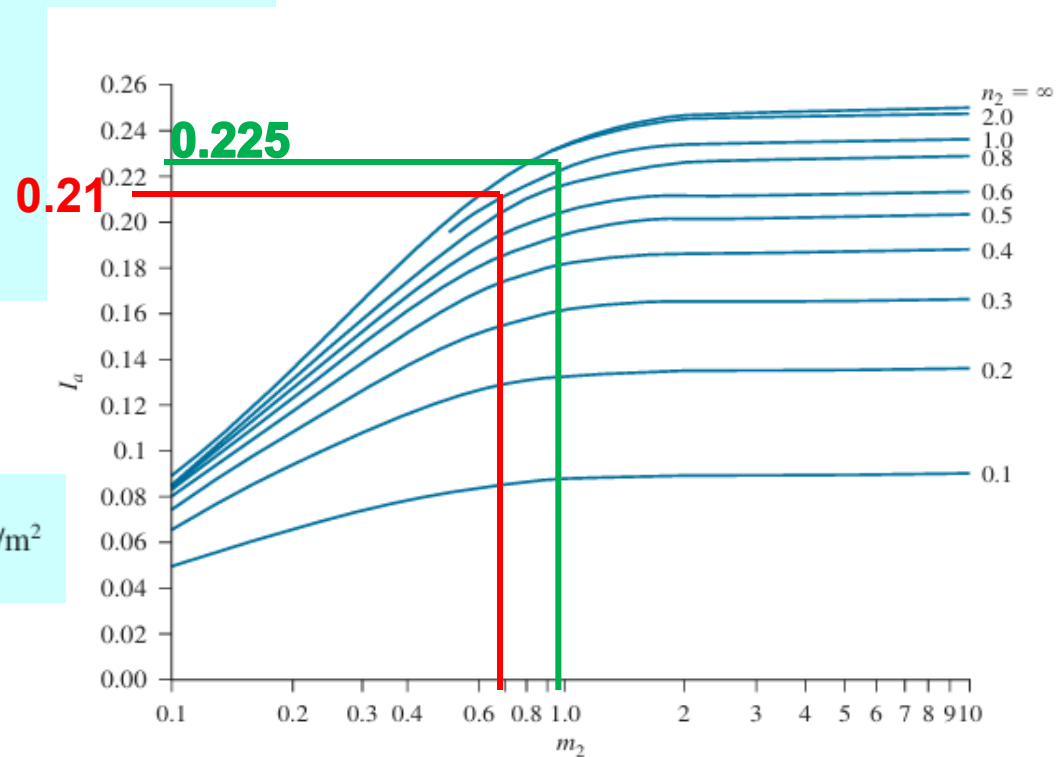

FIGURE 8.13 Griffiths' influence factor I_a

EXAMPLE 10.6

So, the stress increase below the center of the 30 m × 40 m area is (4) (23.32) = 93.28 kN/m². Thus

$$S_{c(p)} = \frac{(0.28)(6)}{1 + 0.9} \log\left(\frac{208 + 93.28}{208}\right) = 0.142 \text{ m}$$

= 142 mm

Structural Design of Mat Foundations

The structural design of mat foundations can be carried out by the following methods:

- The conventional rigid method
- The approximate flexible method.
- Finite-difference and finite-element methods

The Conventional Rigid Method

Step 1. Figure 8.10a shows mat dimensions of $L \times B$ and column loads of Q_1, Q_2, Q_3, \dots . Calculate the total column load as

$$Q = Q_1 + Q_2 + Q_3 + \dots \quad (10.24)$$

Step 2. Determine the pressure on the soil, q , below the mat at points A, B, C, D, \dots , by using the equation

$$q = \frac{Q}{A} + \frac{M_y x}{I_y} + \frac{M_x y}{I_x} \quad (10.25)$$

where

$$A = BL$$

$$I_x = (1/12)BL^3 = \text{moment of inertia about the } x\text{-axis}$$

$$I_y = (1/12)LB^3 = \text{moment of inertia about the } y\text{-axis}$$

$$M_x = \text{moment of the column loads about the } x\text{-axis} = Qe_y$$

$$M_y = \text{moment of the column loads about the } y\text{-axis} = Qe_x$$

x, y = coordinates with appropriate $+/-$ signs

The load eccentricities, e_x and e_y , in the x and y directions can be determined by using (x', y') coordinates:

$$x' = \frac{Q_1 x'_1 + Q_2 x'_2 + Q_3 x'_3 + \dots}{Q} \quad (10.26)$$

and

$$e_x = x' - \frac{B}{2} \quad (10.27)$$

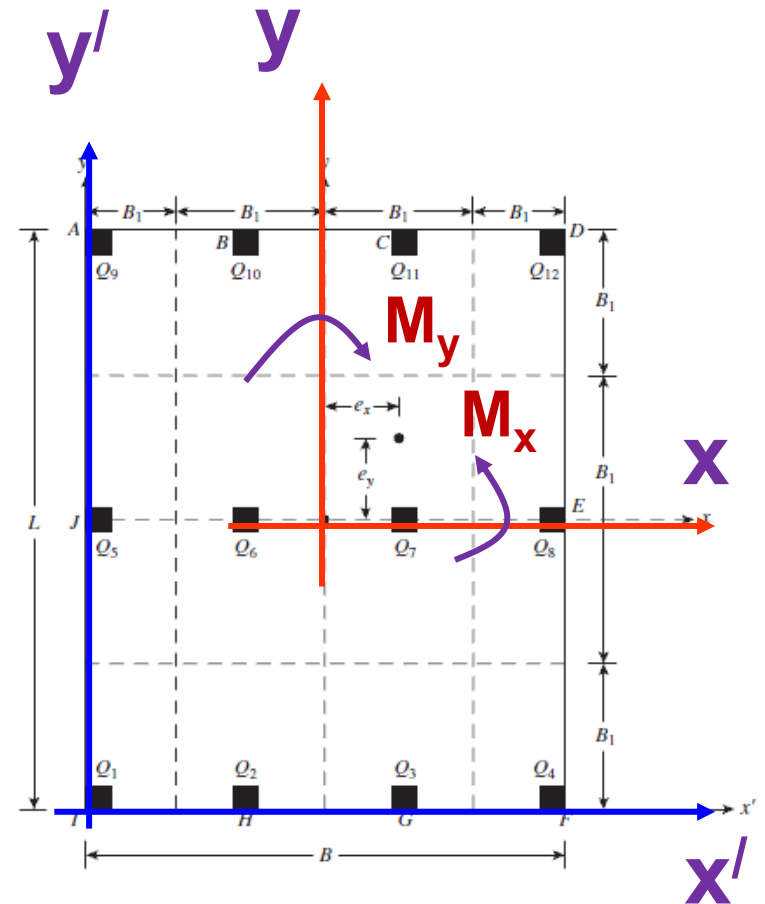

The Conventional Rigid Method

Similarly,

$$y' = \frac{Q_1 y'_1 + Q_2 y'_2 + Q_3 y'_3 + \dots}{Q} \quad (10.28)$$

and

$$e_y = y' - \frac{L}{2} \quad (10.29)$$

It is also possible to determine e_x , e_y using (x, y) coordinates.

Step 3. Compare the values of the soil pressures determined in Step 2 with the net allowable soil pressure to determine whether $q \leq q_{\text{all}(\text{net})}$.

Step 4. Divide the mat into several strips in the x and y directions. (See Figure 10.10.) Let the width of any strip be B_1 .

Step 5. Draw the shear, V , and the moment, M , diagrams for each individual strip (in the x and y directions). For example, the average soil pressure of the bottom strip in the x direction of Figure 10.10a is

$$q_{\text{av}} \approx \frac{q_I + q_F}{2} \quad (10.30)$$

where q_I and q_F = soil pressures at points I and F , as determined from Step 2.

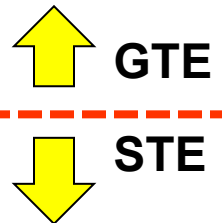

The Conventional Rigid Method

The total soil reaction is equal to $q_{av}B_1B$. Now obtain the total column load on the strip as $Q_1 + Q_2 + Q_3 + Q_4$. The sum of the column loads on the strip will not equal $q_{av}B_1B$, because the shear between the adjacent strips has not been taken into account. For this reason, the soil reaction and the column loads need to be adjusted, or

$$\text{Average load} = \frac{q_{av}B_1B + (Q_1 + Q_2 + Q_3 + Q_4)}{2} \quad (10.31)$$

Now, the modified average soil reaction becomes

Modify Soil Pressure

$$q_{av(\text{modified})} = \frac{\text{average load}}{B_1B} \quad (10.32)$$

and the column load modification factor is

Modify Columns Load

$$F = \frac{\text{average load}}{Q_1 + Q_2 + Q_3 + Q_4} \quad (10.33)$$

So the modified column loads are FQ_1 , FQ_2 , FQ_3 , and FQ_4 . This modified loading on the strip under consideration is shown in Figure 10.10b. The shear and the moment diagram for this strip can now be drawn, and the procedure is repeated in the x and y directions for all strips. From here, the thickness of the mat and the reinforcement details can be determined through structural design considerations according to the American Concrete Institute (ACI) or equivalent codes or design standards.

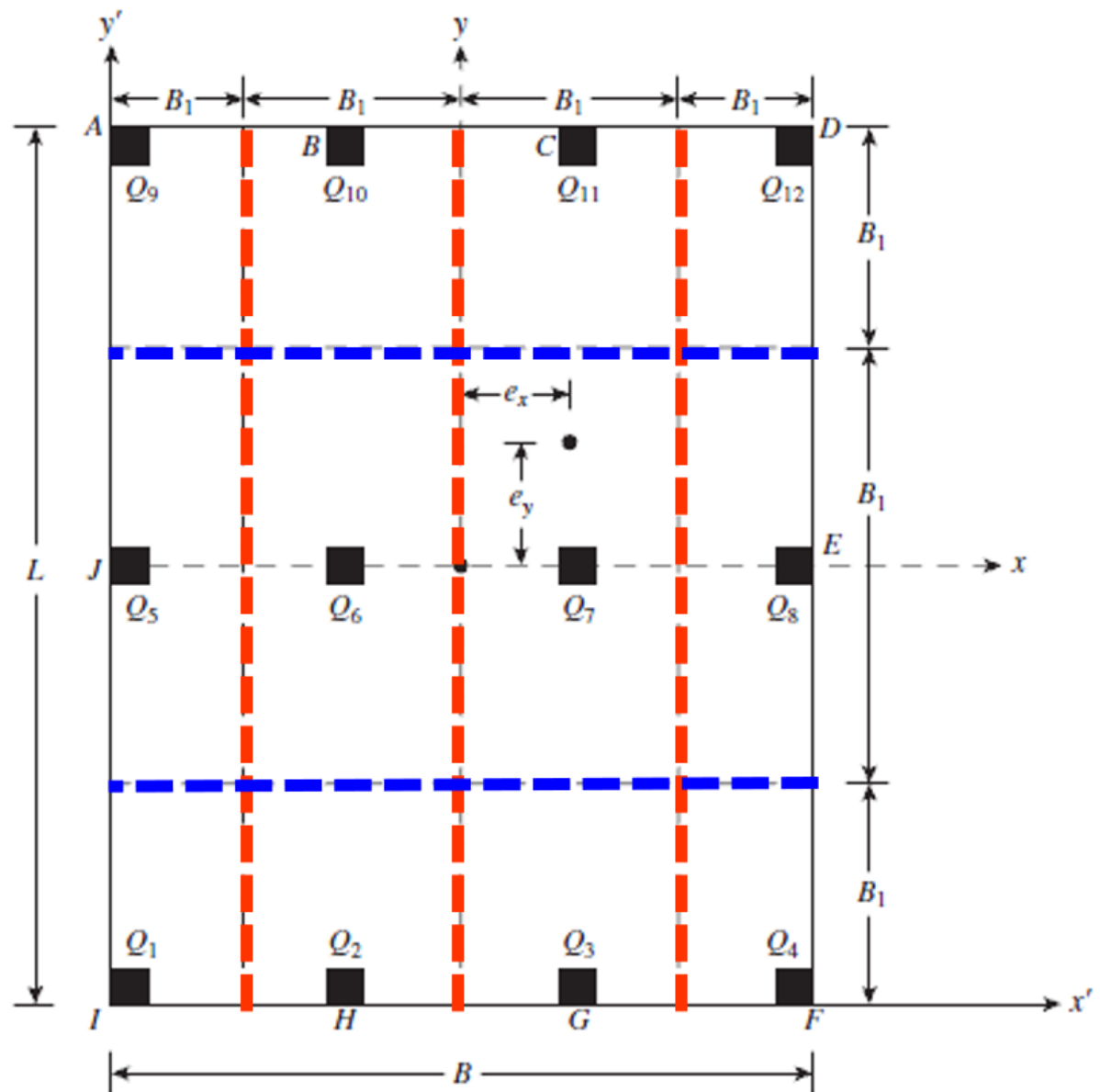

EXAMPLE 10.7

EXAMPLE 10.7

The plan of a mat foundation is shown in Figure 10.14. Calculate the soil pressure at points *A*, *B*, *C*, *D*, *E*, and *F*. (Note: All column sections are planned to be $0.5 \text{ m} \times 0.5 \text{ m}$.)

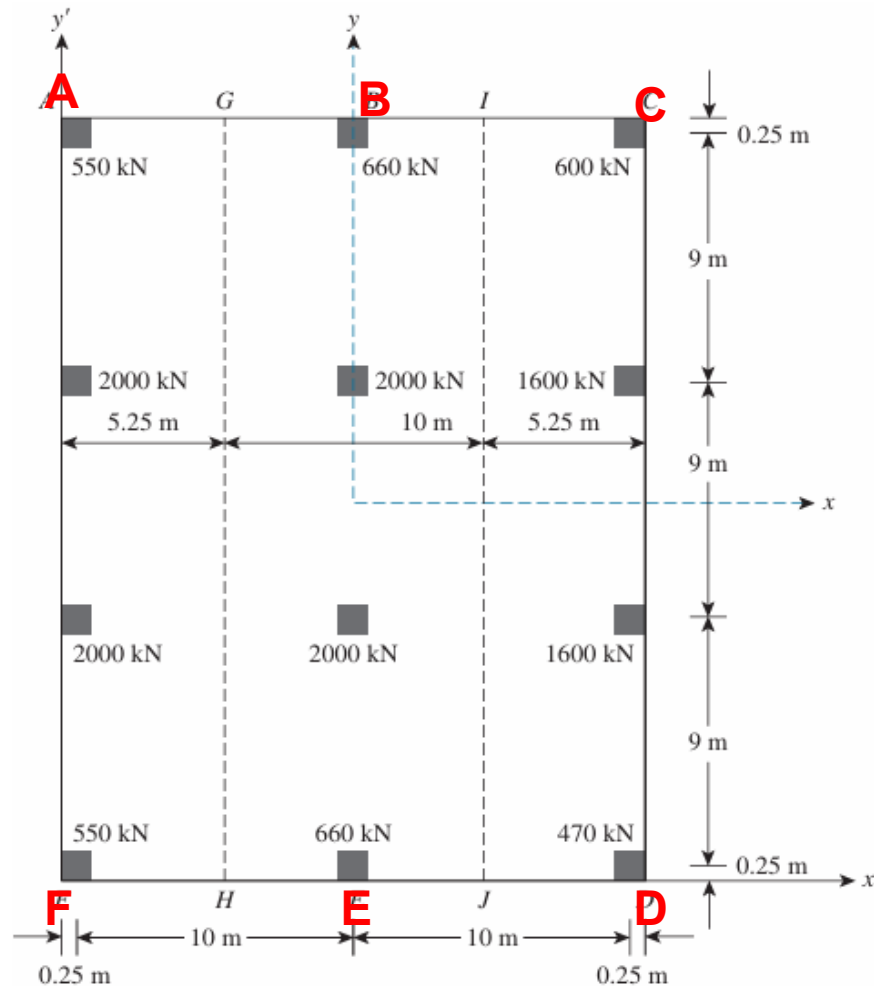

EXAMPLE 10.7

SOLUTION

$$\text{Eq. (10.25): } q = \frac{Q}{A} + \frac{M_y x}{I_y} + \frac{M_x y}{I_x}$$

$$A = (20.5)(27.5) = 563.75 \text{ m}^2$$

$$I_x = \frac{1}{12}BL^3 = \frac{1}{12}(20.5)(27.5)^3 = 35,528 \text{ m}^4$$

$$I_y = \frac{1}{12}LB^3 = \frac{1}{12}(27.5)(20.5)^3 = 19,743 \text{ m}^4$$

$$Q = 470 + (2)(550) + 600 + (2)(660) + (2)(1600) + (4)(2000) = 14,690 \text{ kN}$$

$$M_y = Qe_x; \quad e_x = x' - \frac{B}{2}$$

$$x' = \frac{Q_1x'_1 + Q_2x'_2 + Q_3x'_3 + \dots}{Q}$$

Taking moment
about y' - axis

$$= \frac{1}{14,690} \left[\begin{array}{l} (10.25)(660 + 2000 + 2000 + 660) \\ + (20.25)(470 + 1600 + 1600 + 600) \\ + (0.25)(550 + 2000 + 2000 + 550) \end{array} \right] = 9.686 \text{ m}$$

$$e_x = x' - \frac{B}{2} = 9.686 - 10.25 = -0.565 \text{ m} \approx -0.57 \text{ m}$$

EXAMPLE 10.7

Hence, the resultant line of action is located to the left of the center of the mat. So $M_y = (14,690)(-0.57) = -8373 \text{ kN}\cdot\text{m}$. Similarly,

$$M_x = Qe_y; \quad e_y = y' - \frac{L}{2}$$

$$y' = \frac{Q_1y'_1 + Q_2y'_2 + Q_3y'_3 + \dots}{Q}$$

Taking moment about X'-axis

$$= \frac{1}{14,690} \left[(0.25)(550 + 660 + 470) + (9.25)(2000 + 2000 + 1600) \right. \\ \left. + (18.25)(2000 + 2000 + 1600) + (27.25)(550 + 660 + 600) \right]$$

$$= 13.86 \text{ m}$$

$$e_y = y' - \frac{L}{2} = 13.86 - 13.75 = 0.11 \text{ m}$$

The location of the line of action of the resultant column loads is shown in Figure 10.15.

$$M_x = (14,690)(0.11) = 1616 \text{ kN}\cdot\text{m}$$

So

$$q = \frac{14,690}{563.75} - \frac{8373x}{19743} + \frac{1616y}{35,528} = 26.0 - 0.42x + 0.05y \text{ (kN/m}^2\text{)}$$

Therefore,

$$\text{At A: } q = 26 - (0.42)(-10.25) + (0.05)(13.75) = 31.0 \text{ kN/m}^2$$

$$\text{At B: } q = 26 - (0.42)(0) + (0.05)(13.75) = 26.68 \text{ kN/m}^2$$

$$\text{At C: } q = 26 - (0.42)(10.25) + (0.05)(13.75) = 22.38 \text{ kN/m}^2$$

$$\text{At D: } q = 26 - (0.42)(10.25) + (0.05)(-13.75) = 21.0 \text{ kN/m}^2$$

$$\text{At E: } q = 26 - (0.42)(0) + (0.05)(-13.75) = 25.31 \text{ kN/m}^2$$

$$\text{At F: } q = 26 - (0.42)(-10.25) + (0.05)(-13.75) = 29.61 \text{ kN/m}^2$$

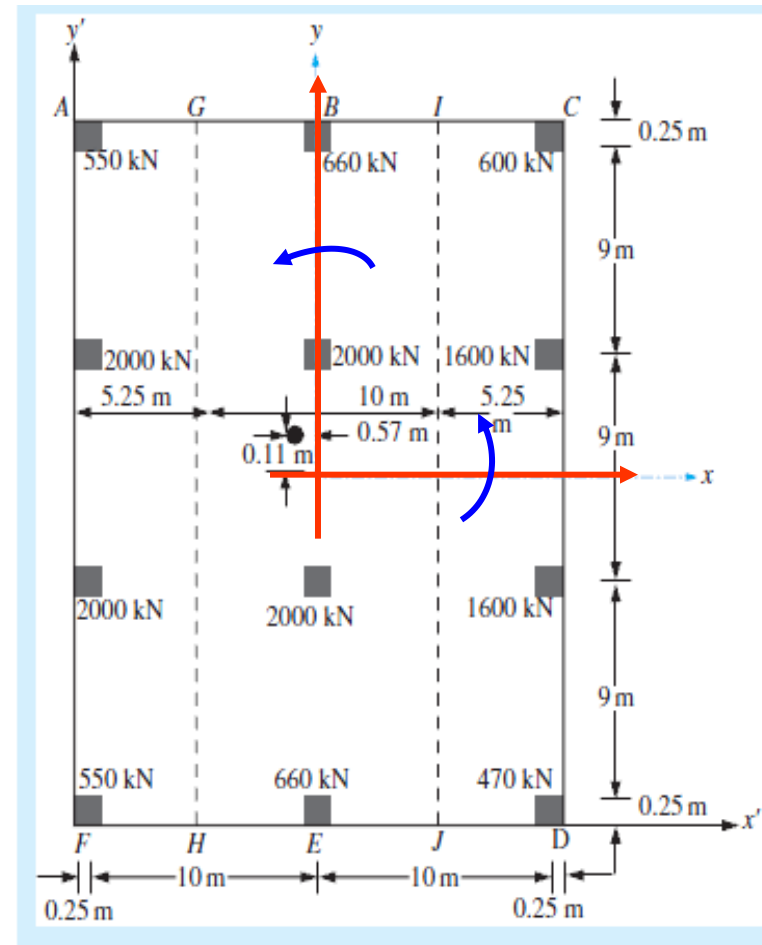

EXAMPLE 10.8 (Modified)

EXAMPLE 10.8

Divide the mat shown in Figure 10.14 into three strips, such as $AGHF$ ($B_1 = 5.25$ m), $GIJH$ ($B_1 = 10$ m), and $ICDJ$ ($B_1 = 5.25$ m). Using the result of Example 10.7,

Show the modified column loads on the strips

SOLUTION

Strip $AGHF$:

$$q_{av} \approx \frac{q_I + q_F}{2}$$

$$\text{Average soil pressure} = q_{av} = q_{(at A)} + q_{(at F)} = \frac{31 + 29.61}{2} = 30.305 \text{ kN/m}^2$$

$$\text{Total soil reaction} = q_{av} B_1 L = (30.305) (5.25) (27.5) = 4375 \text{ kN}$$

$$\text{Columns' Loads} = 550 + 2000 + 2000 + 550 = 5100 \text{ kN}$$

$$\begin{aligned} \text{Average load} &= \frac{\text{load due to soil reaction} + \text{column loads}}{2} \\ &= \frac{4375 + 5100}{2} = 4737.5 \text{ kN} \end{aligned}$$

So, modified average soil pressure [from Eq. 10.32),

$$q_{av(\text{modified})} = \frac{\text{average load}}{B_1 B} = \frac{4737.5}{(5.25)(27.5)} = 32.81 \text{ kN/m}^2$$

The column loads can be modified in a similar manner by multiplying factor

$$F = \frac{4737.5}{5100} = 0.929 \quad F = \frac{\text{average load}}{Q_1 + Q_2 + Q_3 + Q_4}$$

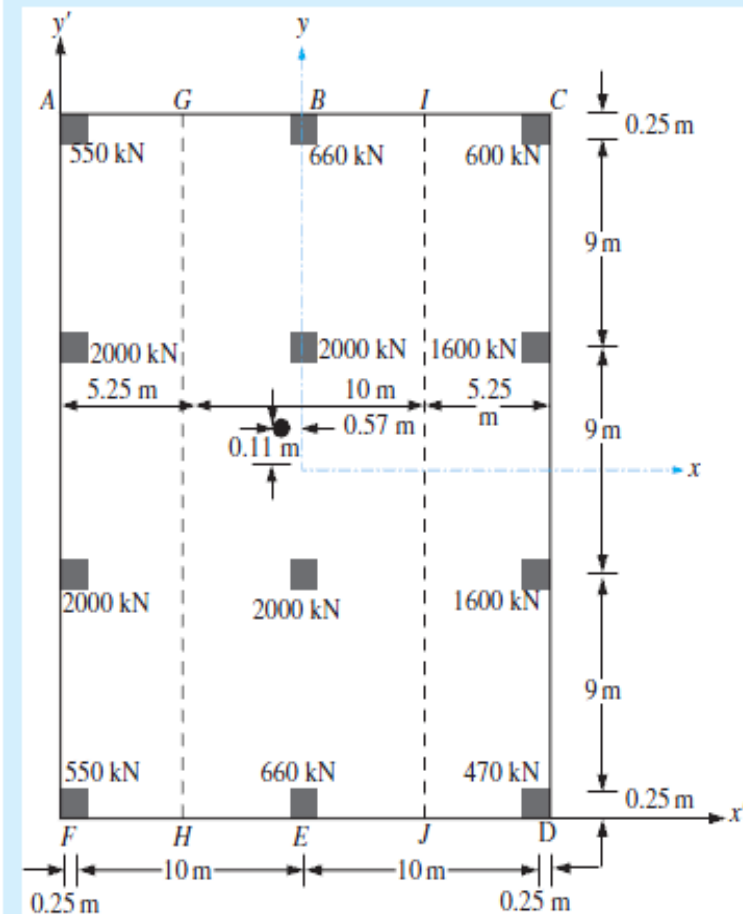

EXAMPLE 10.8 (Modified)

$F = 0.929$. Also the load per unit length of the beam is equal to $B_1 q_{av(modified)} = (5.25)(32.81) = 172.25 \text{ kN/m}$.

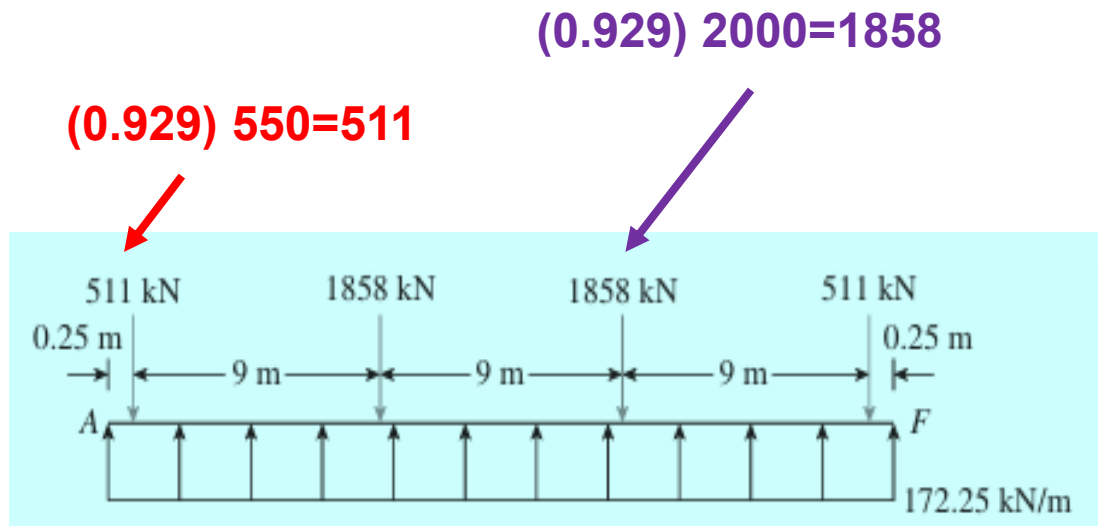

EXAMPLE 10.8 (Modified)

Strip *GIJH*:

$$q_{av} = \frac{q_{(at\ B)} + q_{(at\ E)}}{2} = \frac{26.68 + 25.31}{2} = 26.0 \text{ kN/m}^2$$

$$\text{Total soil reaction} = (26)(10)(27.5) = 7150 \text{ kN}$$

$$\text{Total column load} = 5320 \text{ kN}$$

$$\text{Average load} = \frac{7150 + 5320}{2} = 6235 \text{ kN}$$

$$q_{av(\text{modified})} = \frac{6235}{(10)(27.5)} = 22.67 \text{ kN/m}^2$$

$$F = \frac{6235}{5320} = 1.17$$

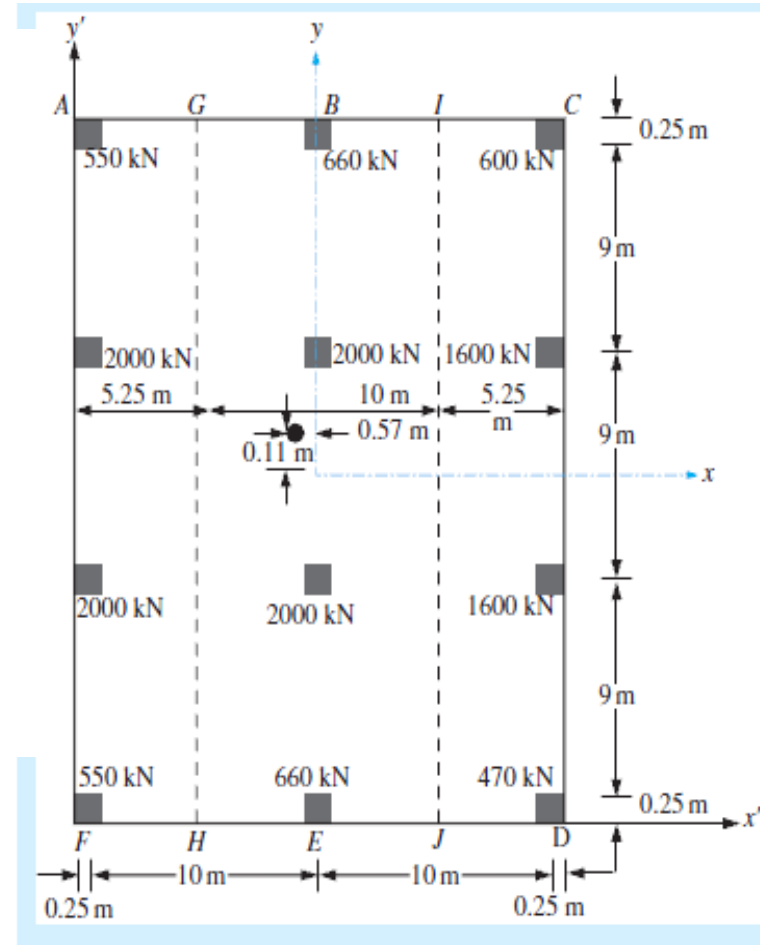

EXAMPLE 10.8 (Modified)

$F = 1.17$. Also the load per unit length of the beam is equal to $B_{1qav(\text{modified})} = (10)(22.67) = 226.7 \text{ kN/m}$.

$$(1.17) 2000 = 2340$$

$$(1.17) 660 = 772$$

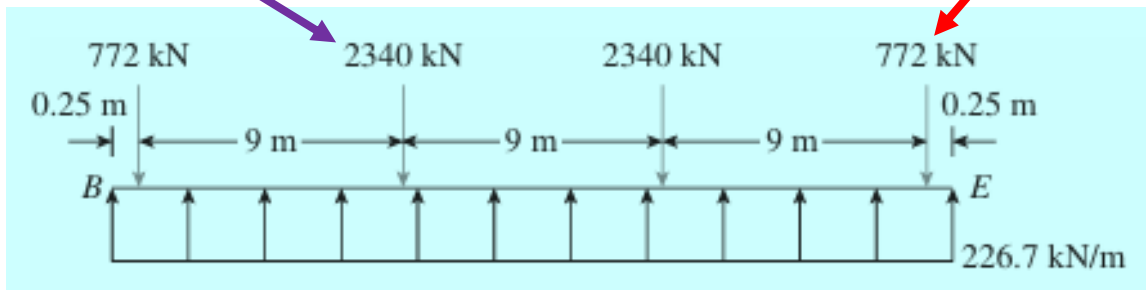

EXAMPLE 10.8 (Modified)

Strip *ICDJ*

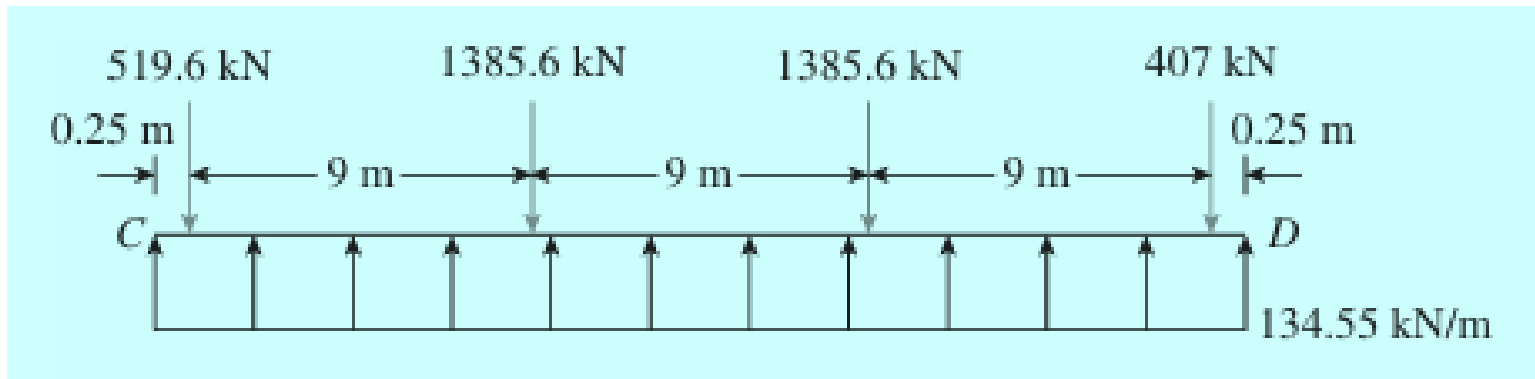

Design of Mat Foundations

In the **conventional rigid method** of design, the mat is assumed to be infinitely rigid. Also, the soil pressure is distributed in a straight line, and the centroid of the soil pressure is coincident with the line of action of the resultant column loads.

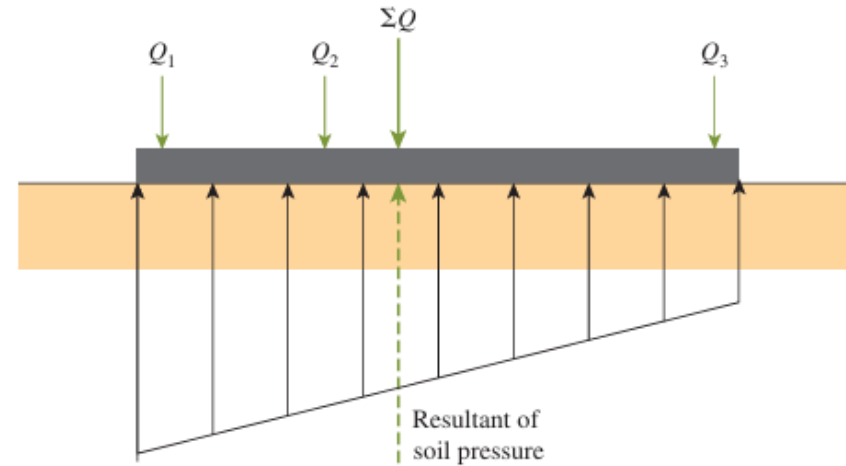

In the **approximate flexible method** of design, the soil is assumed to be equivalent to an infinite number of elastic springs, as shown in the figure. This assumption is sometimes referred to as the **Winkler foundation**. The elastic constant of these assumed springs is referred to as the **coefficient of subgrade reaction, k** .

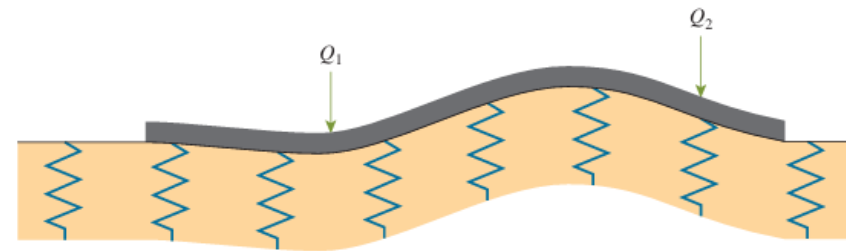

Design of Mat Foundations

$$\beta = \sqrt[4]{\frac{B_1 k}{4E_F I_F}}$$

E_F = modulus of elasticity of foundation material

I_F = moment of inertia of the cross section of the beam = $\left(\frac{1}{12}\right)B_1 h^3$

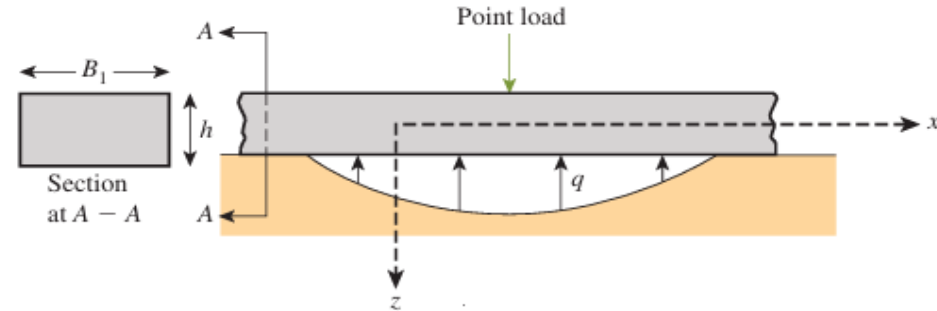

The parameter β is very important in determining whether a mat foundation should be designed by the conventional rigid method or the approximate flexible method.

According to the American Concrete Institute Committee 336 (1988), mats should be designed by the conventional rigid method if the spacing of columns in a strip is less than $1.75/\beta$.

If the spacing of columns is larger than $1.75/\beta$, the approximate flexible method may be used.

The coefficient of subgrade reaction

If a foundation of width B is subjected to a load per unit area of q , it will undergo a settlement Δ . The coefficient of subgrade reaction can be defined as:

$$k = \frac{q}{\Delta}$$

The unit of k is kN/m^3

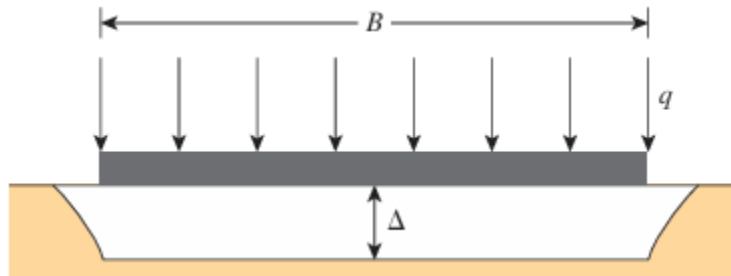

The value of the coefficient of subgrade reaction is not a constant for a given soil, but rather depends on several factors, such as the length L and width B of the foundation and also the depth of embedment of the foundation.

A comprehensive study by Terzaghi (1955) of the parameters affecting the coefficient of subgrade reaction indicated that the value of the coefficient decreases with the width of the foundation.

In the field, load tests can be carried out by means of square plates measuring $0.3 \text{ m} \times 0.3 \text{ m}$, and values of k can be calculated. The value of k can be related to large foundations measuring $B \times B$.

The coefficient of subgrade reaction

Foundations on Sandy Soils

$$k = k_{0.3} \left(\frac{B + 0.3}{2B} \right)^2$$

Foundations on Clays

$$k(\text{kN/m}^3) = k_{0.3}(\text{kN/m}^3) \left[\frac{0.3 \text{ (m)}}{B \text{ (m)}} \right]$$

where $k_{0.3}$ and k = coefficients of subgrade reaction of foundations measuring $0.3 \text{ m} \times 0.3 \text{ m}$ and $B \text{ (m)} \times B \text{ (m)}$, respectively (unit is kN/m^3).

The coefficient of subgrade reaction

For rectangular foundations having dimensions of $B \times L$:

$$k = \frac{k_{(B \times B)} \left(1 + 0.5 \frac{B}{L} \right)}{1.5}$$

k = coefficient of subgrade reaction of the rectangular foundation ($L \times B$)

$k_{(B \times B)}$ = coefficient of subgrade reaction of a square foundation having dimension of $B \times B$

The value of k for a very long foundation with a width B is approximately $0.67k_{(B \times B)}$

$$k = \frac{E_s}{B(1 - \mu_s^2)}$$

E_s = modulus of elasticity of soil

B = foundation width

μ_s = Poisson's ratio of soil

The coefficient of subgrade reaction

TABLE 10.2 Typical Subgrade Reaction Values, $k_{0.3}$

Soil type	$k_{0.3}$ (MN/m ³)
Dry or moist sand:	
Loose	8–25
Medium	25–125
Dense	125–375
Saturated sand:	
Loose	10–15
Medium	35–40
Dense	130–150
Clay:	
Stiff	10–25
Very stiff	25–50
Hard	>50

The end