

Chapter 5

Compacting and Finishing

5-1 PRINCIPLES OF COMPACTION

- **The Compaction Process**
- **Optimum Moisture Content**
- **Compaction Specifications**
- **Measuring Field Density**

The Compaction Process

- *Compaction:*
 - is the process of increasing the density of a soil by **mechanically** forcing the soil particles closer together, thereby expelling air from the void spaces in the soil.
- *Consolidation:*
 - is an increase in soil density of a cohesive soil resulting from the **expulsion of water** from the soil's void spaces (**naturally**).
- Consolidation may require **months or years** to complete, whereas compaction is accomplished in a matter of **hours**.

	Compaction force	Cause of compaction	Time	Soil type
Compaction	Mechanical	expulsion of air	hours	Almost all types
Consolidation	Natural	expulsion of water	Months or years	Cohesive

The Compaction Process

- Compaction has been employed for centuries to improve the engineering properties of soil.
- Improvements include:
 1. increased bearing strength
 2. reduced compressibility
 3. improved volume-change characteristics
 4. reduced permeability

The Compaction Process

- the equipment and methods employed for compaction in building construction are usually somewhat different from those employed in heavy and highway construction because of:
 - the limited differential settlement that can be tolerated by a building foundation
 - the necessity for working in confined areas close to structures
 - the smaller quantity of earthwork involved.

The Compaction Process

- The degree of compaction (**effectiveness**) may be achieved in a particular soil depends upon:
 1. the soil's physical and chemical properties
 2. the soil's moisture content
 3. the compaction method employed
 4. the amount of compactive effort (from Proctor tests standard or modified)
 5. the thickness of the soil layer being compacted (lift thickness).

The Compaction Process

- The four basic compaction forces are:
 1. static weight
 2. manipulation (or kneading)
 3. impact
 4. vibration.
- Most compactors combine static weight with one of the other three forces

The Compaction Process

- The forces involved in impact and vibration are similar except for their frequency.
 - Impact or tamping involves blows delivered at low frequencies:
 - usually about **10** cycles per second (Hz)
 - It is most effective in plastic soils.
 - Vibration involves higher frequencies:
 - may extend to **80** cycles per second (Hz) or more.
 - Vibration is particularly effective in compaction of cohesionless soils such as sand and gravel.

Optimum Moisture Content

Soil moisture content:

- is one of the five factors influencing compaction results
- it is a very important one.
- A standard laboratory test called a *Proctor test* has been developed to evaluate a soil's moisture density relationship under a specified compaction effort.
- There are two Proctor tests:
 - Standard Proctor Test (ASTM D 698, AASHTO T-99) and
 - Modified Proctor Test (ASTM D 1557, AASHTO T-180).

TABLE 5-1: Characteristics of Proctor compaction tests

Test Details	Standard	Modified
Diameter of mold		
in.	4	4
mm	102	102
Height of sample		
in.	5 cut to 4.59	5 cut to 4.59
mm	127 cut to 117	127 cut to 117
Number of layers	3	5
Blows per layer	25	25
Weight of hammer		
lb	5.5	10
kg	2.5	4.5
Diameter of hammer		
in.	2	2
mm	51	51
Height of hammer drop		
in.	12	18
mm	305	457
Volume of sample		
cu ft	$\frac{1}{30}$	$\frac{1}{30}$
l	0.94	0.94
Compactive effort		
ft-lb/cu ft	12,400	56,200
kJ/m ³	592	2693

Optimum Moisture Content

- The modified test:
 - It was developed for use where high design loads are involved (such as airport runways)
 - From the previous table, the compactive effort for the modified test is more than four times as great as for the standard test.

- To determine the maximum density of a soil using Proctor test procedures, compaction tests are performed over a range of soil moisture contents
- The peak of each curve represents the maximum density obtained under the compactive effort supplied by the test.

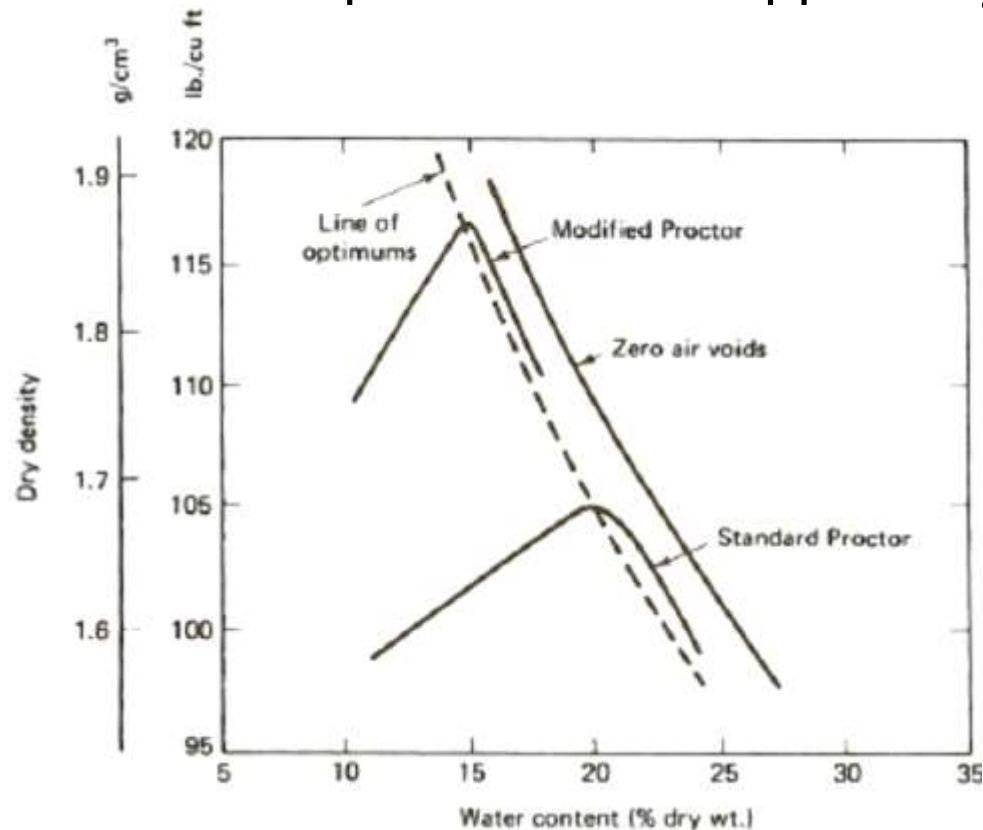
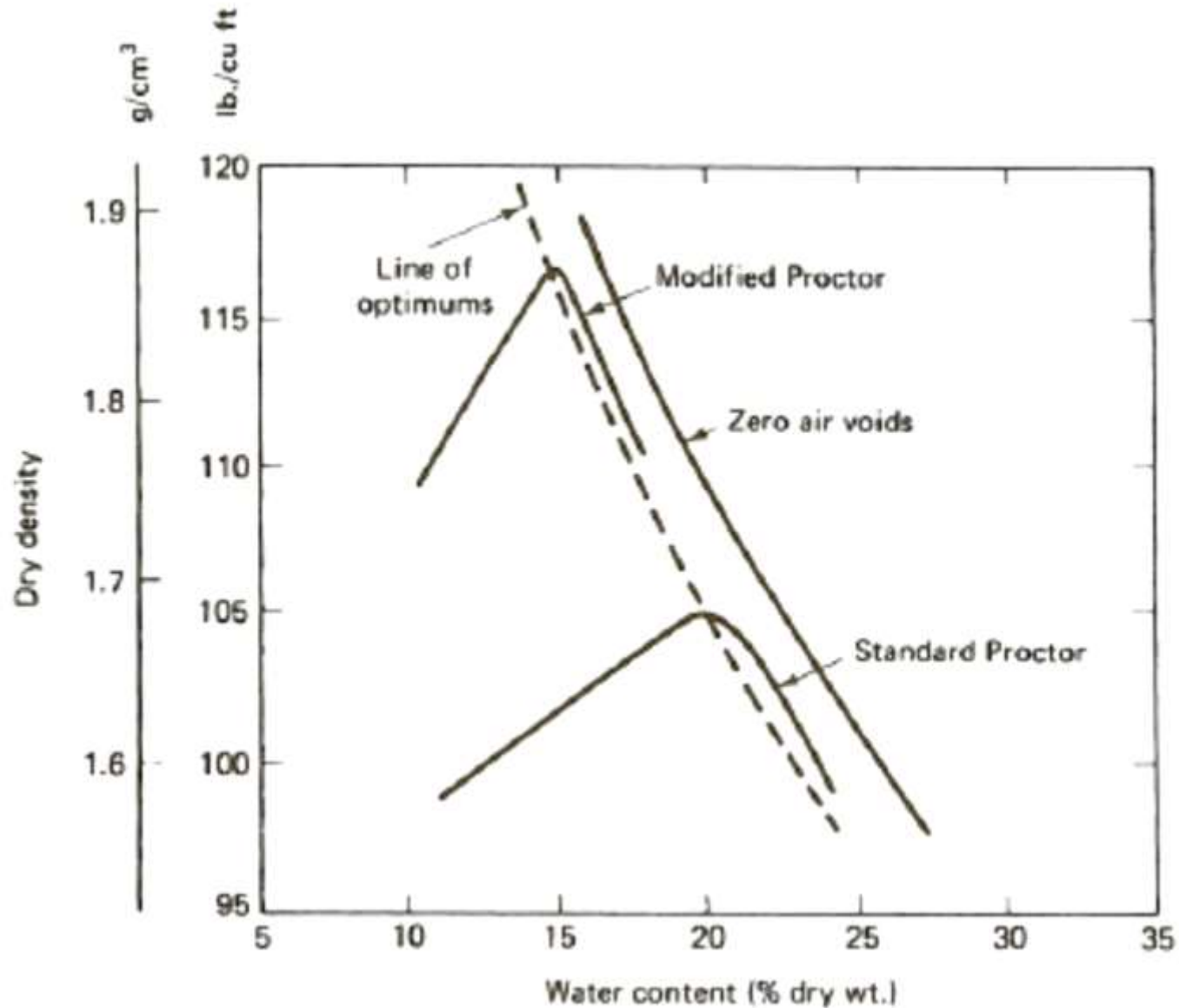
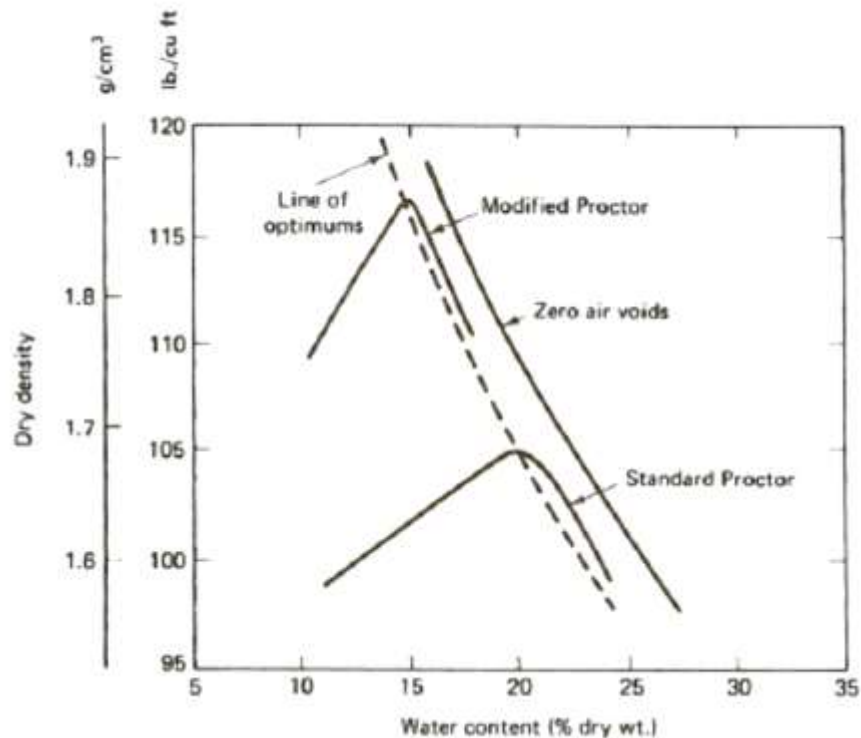

FIGURE 5-1: Typical compaction test results.



- Comments on Figure 5-1 are:
 - maximum density achieved under the greater compactive effort of the modified test is **higher** than the density achieved in the standard test.
 - the line labeled "zero air voids" represents the maximum possible soil density for any specified water content.



- *Optimum moisture content* of a soil is the moisture content at which maximum dry density is achieved under a specific compaction effort.
 - 20% for Standard Proctor Test.
 - 15% for the modified test.
- This relationship is typical for most soils where soil's optimum moisture content **decreases** as the compactive effort is increased.
 - The line of optimum moisture contents demonstrates that.

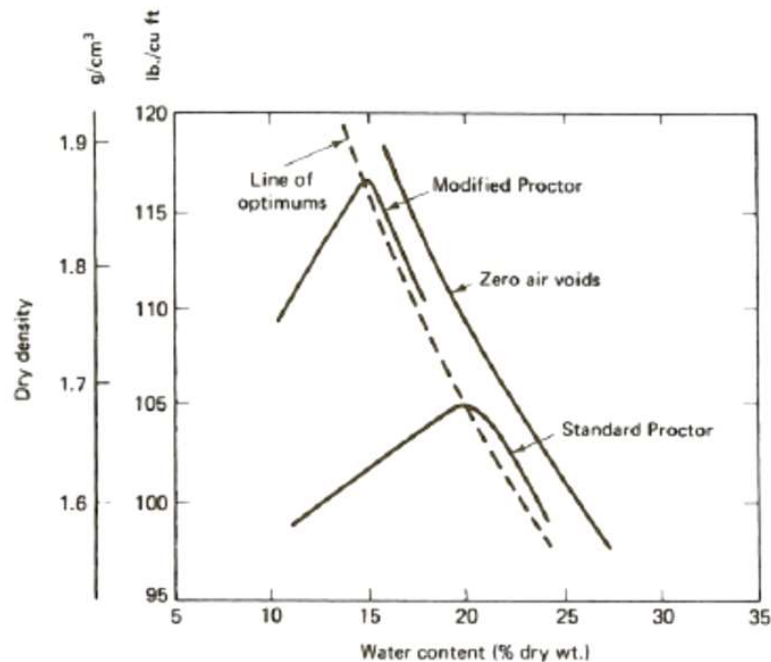

- The importance of soil moisture content **to field compaction practice** can be demonstrated using Figure 5-1.
 - Suppose that specifications require a density of 100 lb/cu ft (1.6 g/cm³) for this soil and the compactive effort being used is equal to that of the Standard Proctor Test. From the Figure below it can be seen that the required density may be achieved at any moisture content between 13 and 24%.
 - A density of 105 lb/cu ft (1.68 g/cm³) can only be achieved at a moisture content of 20%.

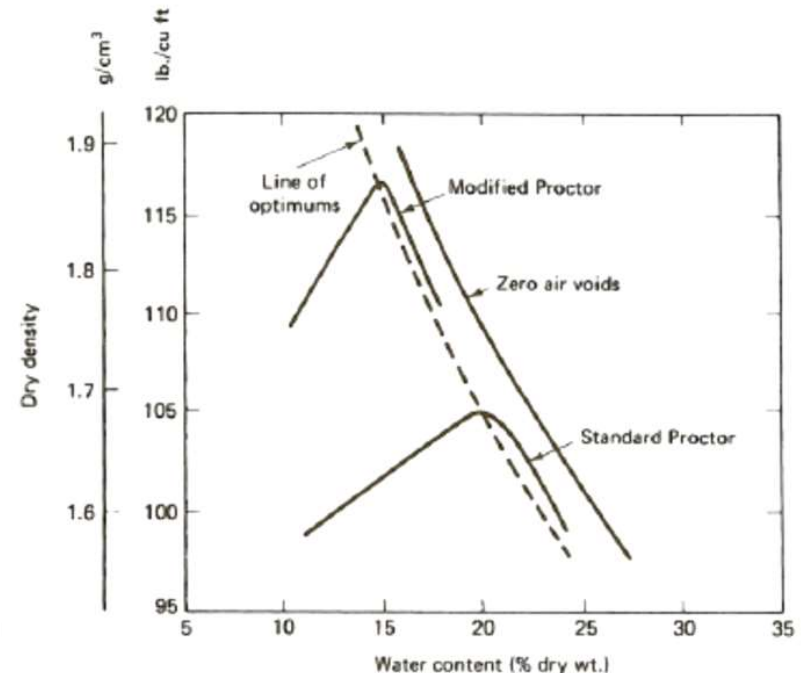
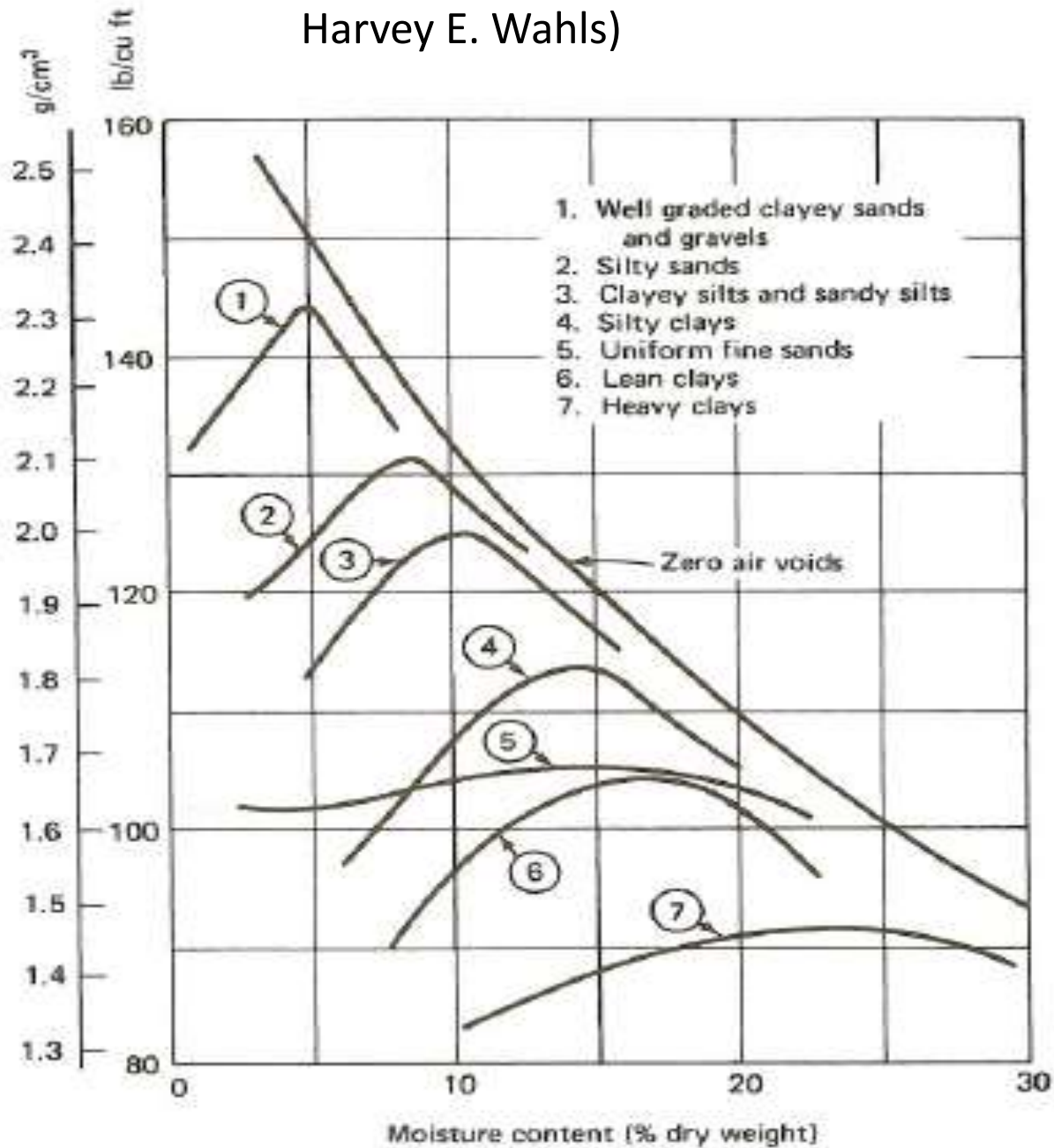

FIGURE 5-2: Modified Proctor Test results for various soils. (Courtesy of Dr. Harvey E. Wahls)



Compaction Specifications

- Compaction specifications are intended to ensure that the compacted material provides:
 1. The required engineering properties
 2. Satisfactory level of uniformity.
- 1. The required engineering properties
 - A- Prescribing the characteristics of the material to be used
 - B- a minimum dry density to be achieved.
 - The Proctor test is widely used for expressing the minimum density requirement.
 - The specification will state that a certain percentage of Standard Proctor or Modified Proctor density must be obtained.

Compaction Specifications

- As in an example, the soil of Figure 5-1 shown below,
 - 100% of Standard Proctor density corresponds to a dry density of 105 lb/cu ft (1.68 g/cm^3).
 - Thus a specification requirement for 95% of Standard Proctor density corresponds to a minimum dry density of 99.8 lb/cu ft (1.60 g/cm^3).

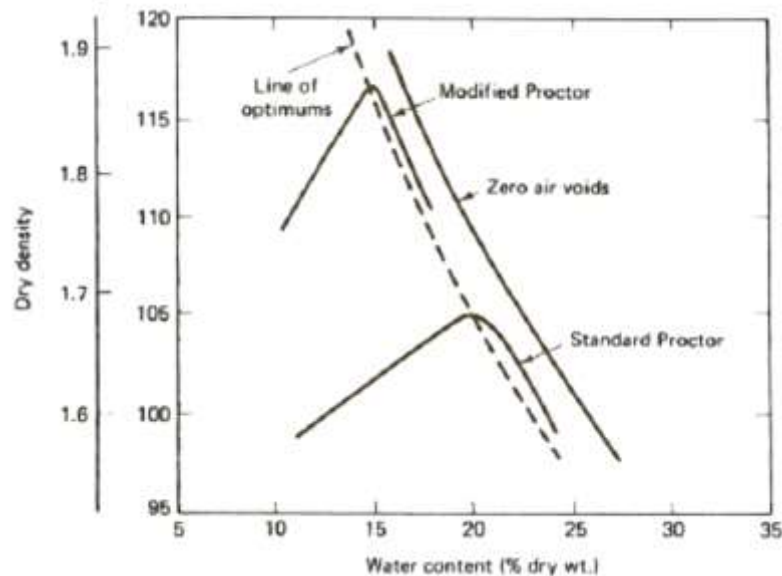

Compaction Specifications

- Typical density requirements range from 90% of Standard Proctor to 100% of Modified Proctor. For example,
 - 95% of Standard Proctor is often specified for embankments, dams, and backfills.
 - 90% of Modified Proctor might be used as requirement for the support of floor slabs.
 - 95 to 100% of Modified Proctor are commonly used as requirement for the support of structures and for pavement base courses where high wheel loads are expected.

Compaction Specifications

- 2. satisfactory level of uniformity :
 - A lack of uniformity in compaction may result in:
 - differential settlement of structures or
 - may produce a bump or depression in pavements.
- it is important that uniform compaction be obtained.
- Uniformity is commonly controlled by specifying a maximum variation of density between adjacent areas.

Compaction Specifications

- Types of Compaction specifications are:
 - 1) **Performance specifications** in which only a minimum dry density is prescribed
 - 2) **Method specifications** that prescribe the exact equipment and procedures to be used

٢-٥ ردم خنادق الأنابيب وحول غرف التفقيش وأحواض التجميع:
يجب أن لا تبدأ أية عمليات للردم حتى تزال كل المواد غير المرغوبة من الخندق والحصول على موافقة كتابية من المهندس.

ويتم ردم ذلك الجزء من الخندق والذي يبدأ من منتصف الأنبوب حتى ٣٠ سم فوق مسطحة العلوي برمل غير مغسول وبذلك كثافة ٩٠ %، وأن جزءاً يعمق ٣٠ سم تحت المنسوب السفلي للرصيف الخرساني ورنمه على طبقتين بمواد طبقة تحت الأساس المعتمدة، كل طبقة بسمك ١٥ سم ومذكورة بكثافة ١٠٠ % . إن الجزء تحت طبقة تحت الأساس حتى السطح العلوي للرمل غير المغسول ينبغي رنمه بمادة معتمدة على طبقات لا تزيد سماكته عن ٣٠ سم لكل طبقة وينبغي دكته حتى كثافة ٩٥ % . ويجب أن تجري كافة اختبارات الكثافة عن طريق اختبار بركتور المعدل من مواصفات (ASTM 1557-70).

٣-٥ ردم حفريات القناة الصندوقية:

الردم مماثل لخندق الأنبوب حيث يتوجب إزالة كافة المواد غير المرغوبة وينبغي الحصول على إذن بالشروع في الردم من المهندس يتم وضع علامات في السطوح الخارجية للقناة الصندوقية ووجه الخندق كل ٣٠ سم وذلك لغرض فرد ونشر ودك مواد الردم المعتمدة على طبقات. إن آخر أعلى ٣٠ سم تحت منسوب الإسفلت (في الأماكن التي بها أسفلت) يتم رنمه بشكل مماثل لطريقة ردم خندق الأنبوب . وقيل فرد ونشر أية طبقة من مواد الردم ينبغي إعلام ممثل المهندس بذلك ولن يسمح أن يبدأ عمليات الردم في أي جزء من أجزاء العمل طالما يوجد خرسانة مصبوبة في الموقع لم يمضي عليها ثلاثة أيام على أقل تقدير .

٤-٥ اختبار الردم:

يجب اختبار أي مصدر لمادة الردم ليطابق التدرج ولتحديد معايير أخرى مطلوبة لتحديد الكثافات الحقلية، وما لم يذكر خلاف ذلك فإن طريقة استبدال الرمل يجب أن تستخدم لاختبار الكثافة الحقلية ويجب إجراء اختبار واحد على الأقل للطبقات المتعلقة بين كل مقطع أو في كل ١٠٠ م . واستخدام الرصاصات في الردم يكون وفق الجدول التالي:

أقل ارتفاع للردم فوق الأنابيب والقناة الصندوقية	نوع المعدة
٣٠٠ ملم	دكاه يدوي ١٥ كجم
٦٠٠ ملم	مطرقة هزازة ١٠٠ كجم
٣٠٠ ملم	لوحة هزاز ١٠٠ كجم
٩٠٠ ملم	لوحة هزاز ٦٠٠ كجم
٦٠٠ ملم	رصاصات وزن ٢ طن
١٢٠٠ ملم	رصاصات وزن ٤ طن
١٨٠٠ ملم	رصاصات وزن ١٠ طن

Example from a contract for storm water pipeline

Measuring Field Density

- To verify the adequacy of compaction, the soil density actually obtained in the field must be measured and compared with the specified soil density.
- The methods available for performing in-place density tests include:
 - a number of traditional methods (liquid tests, sand tests, etc.)
 - nuclear density devices.

Measuring Field Density

- All the traditional test methods involve:
 - removing a soil sample
 - measuring the volume of the hole produced
 - determining the dry weight of the material removed.
- Density is then found as the dry weight of soil removed divided by the volume of the hole.

Measuring Field Density

- *Nuclear density devices* :
 - measure the amount of radioactivity from a calibrated source that is reflected back from the soil to determine both **soil density and moisture content**.
 - When properly calibrated and operated, these devices produce accurate results in a fraction of the time required to perform traditional density tests.
 - The use of nuclear density devices is becoming widespread because of increased need of rapid soil density determination.

Intelligent Compaction

Technologies have been developed by several manufacturers of construction equipment that provide real-time measurement of the stiffness of the compacted lift.

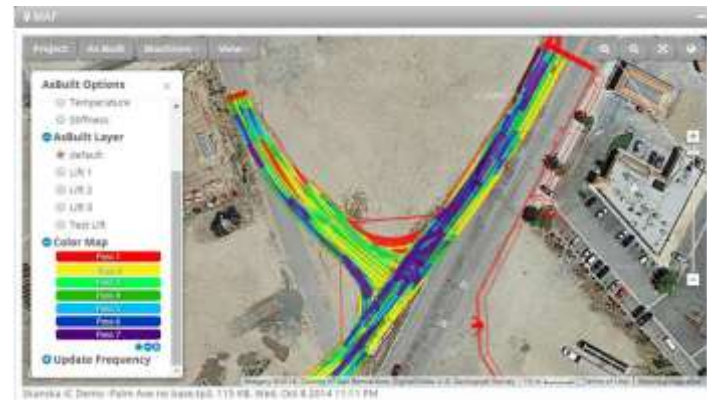
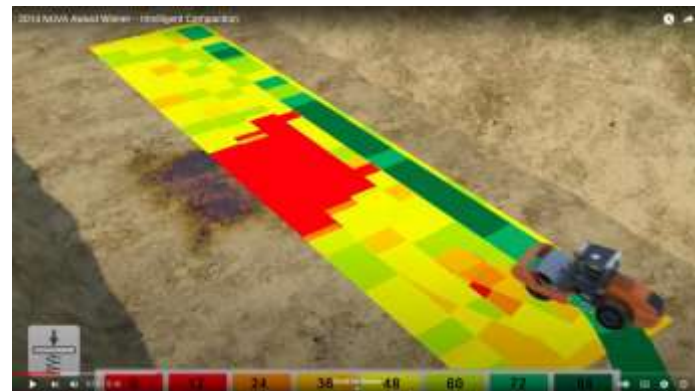

https://www.youtube.com/watch?v=jmrl_bpcRVY&t=137s

5-2 COMPACTION EQUIPMENT AND PROCEDURES

- **Types of Compaction Equipment**
- **Compaction in Confined Areas**
- **Selection of Compaction Equipment**
- **Compaction Operations**
- **Estimating Compactor Production**
- **Job Management**

Types of Compaction Equipment

- Principal types of compaction equipment include:
 1. tamping foot rollers
 2. grid or mesh rollers
 3. vibratory compactors
 4. smooth steel drum rollers
 5. pneumatic rollers
 6. segmented pad rollers
 7. tampers or rammers.

Summary of Compaction Equipment

<i>Equipment</i>	<i>Compaction force</i>	<i>Application</i>	<i>Additional information</i>
<i>Tamping foot rollers</i>	static weight and manipulation	cohesive soils	
<i>Grid or mesh rollers</i>	static weight and impact plus limited manipulation	<ul style="list-style-type: none"> • Compact clean gravels and sands (most effective) • Break up lumps of cohesive soils • Crush and compact soft rock 	Operate at high speed without scattering the material
<i>Vibratory compactors</i>	Vibration and weight	<ul style="list-style-type: none"> • Almost all types of soils • Most effective with rocks, gravels, and sands 	Sizes: <ul style="list-style-type: none"> • Small hand-operated compactors • Towed rollers to large self-propelled rollers Type: <ul style="list-style-type: none"> • Plate compactors • Smooth drum rollers • Tamping foot rollers
<i>Steel wheel or smooth drum rollers</i>	Static weight	<ul style="list-style-type: none"> • Granular bases • Asphaltic bases • Asphalt pavement 	
<i>Rubber-tired or pneumatic rollers</i>	Static weight	<ul style="list-style-type: none"> • Almost all types of soils • Least effective on-clean sands and gravels 	Available as: <ul style="list-style-type: none"> • Light- to medium weight multi tired rollers and • Heavy pneumatic rollers (up to 200 ton → used in dam construction and compaction of thick lifts)
<i>Rammers or tampers</i>	Impact	Compaction in confined areas	Small impact-type compactors

1. Tamping foot rollers:



2. Grid or mesh rollers:



3. Vibratory compactors:

FIGURE 5-3: Major types of compaction equipment.

(Reprinted by permission of Caterpillar Inc., ©1971)

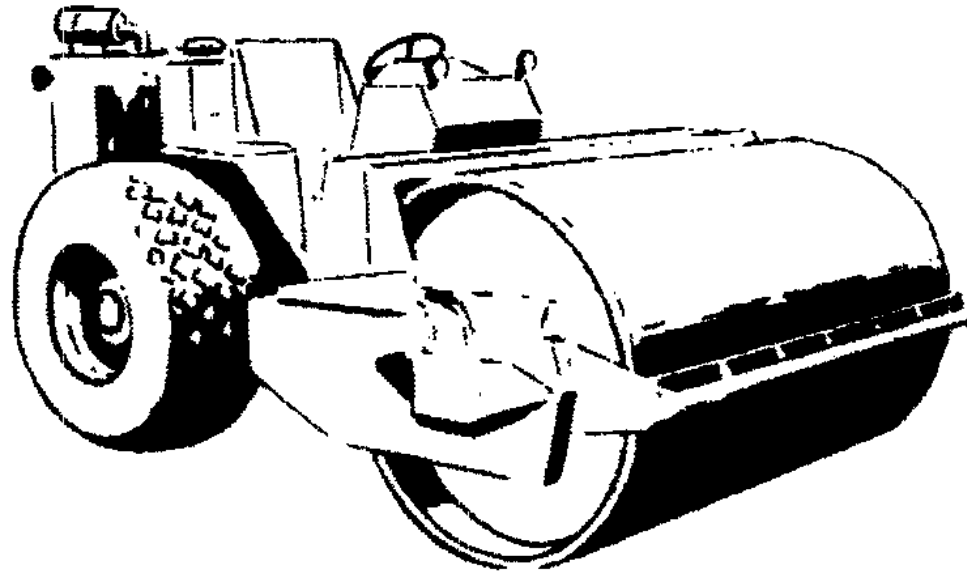

**SELF-PROPELLED
VIBRATING ROLLER**

FIGURE 5-4: Walk-behind vibratory plate compactor.
(Courtesy of Wacker Corp.)



FIGURE 5-5: Vibratory tamping foot compactor.

[Courtesy of BOMAG (USA)]



- Vibratory plate compactors are also available as attachments for hydraulic excavators.



4. Steel wheel or smooth drum rollers :

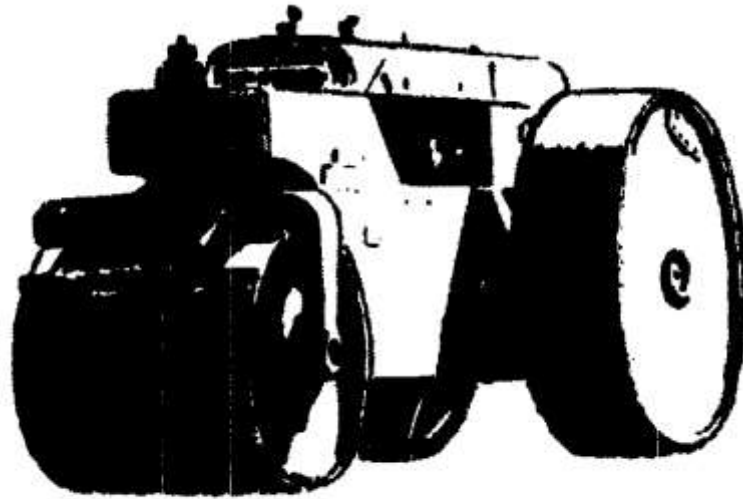

SMOOTH, STEEL WHEEL ROLLER

5. Rubber-tired or pneumatic rollers :

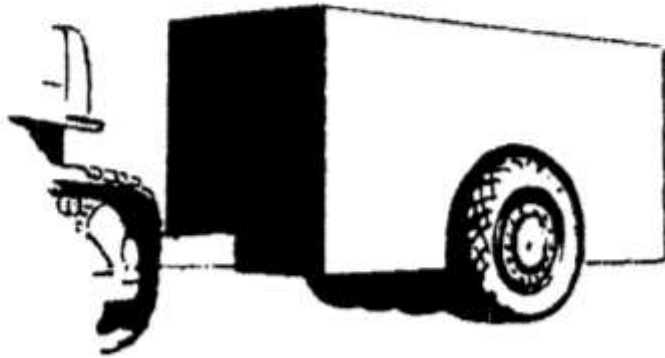

HEAVY PNEUMATIC
ROLLER



6. *Segmented pad rollers :*

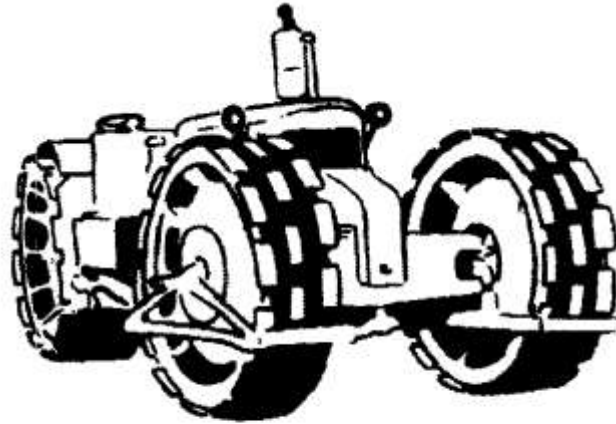

**SELF-PROPELLED SEGMENTED
STEEL WHEEL ROLLER**

7. *Rammers or tampers :*

FIGURE 5-6: Small vibratory rammer.
(Courtesy of Wacker Corp.)



Compaction in Confined Areas

- The equipment available for compaction in confined areas are:
 - For trenches and around foundations includes small vibratory plate compactors (Figure 5-4)
 - tampers or rammers (Figure 5-6)
 - walk-behind static and vibratory rollers (Figure 5-7)
 - attachments for backhoes and hydraulic excavators.
 - *Compaction Wheels* (Figure 5-8)
 - *Vibratory plate attachments* (Figure 5-9)

FIGURE 5-4: Walk-behind vibratory plate compactor.
(Courtesy of Wacker Corp.)



FIGURE 5-7: Walk-behind vibratory roller with remote control.



FIGURE 5-8: Compaction wheel mounted on hydraulic excavator.
(Courtesy of American Compaction Equipment, Inc.)

<https://www.youtube.com/watch?v=oc81V87BgpU>



FIGURE 5-9: Vibratory plate compactor attachment for excavator

(Courtesy of Ingersoll-Rand Tramac)

https://www.youtube.com/watch?v=z7ICdFd9Y_M

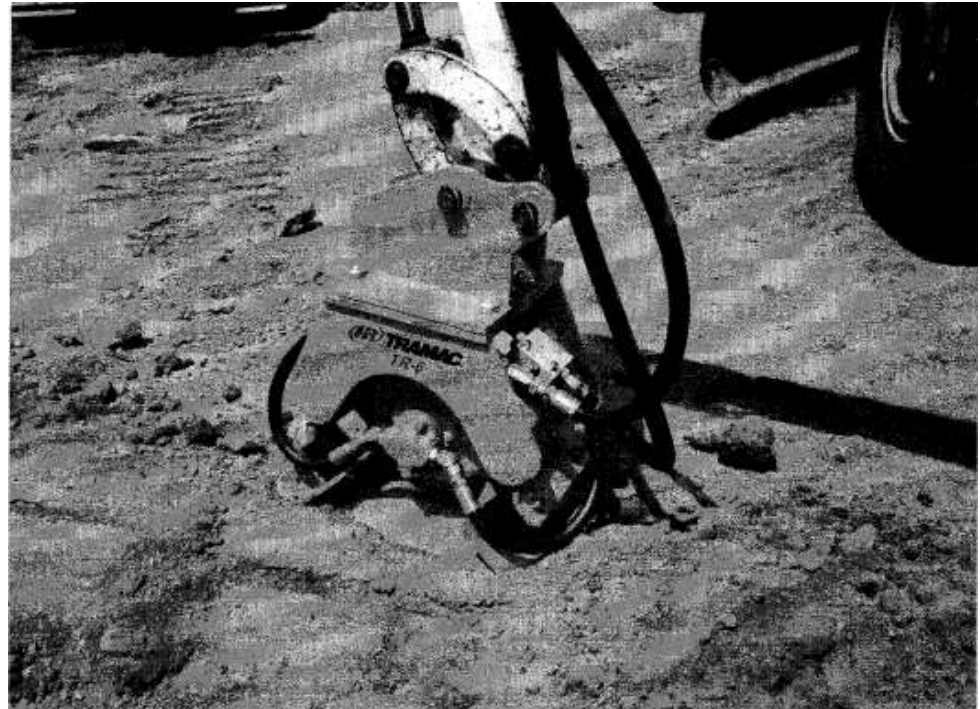
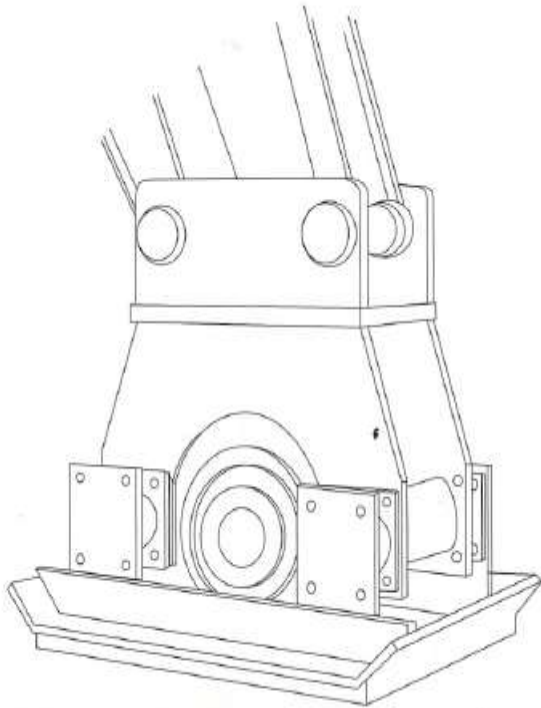

Selection of Compaction Equipment

- The proper selection of compaction equipment is an important factor in obtaining the required soil density with a minimum expenditure of time and effort.

The chart shown below provides a rough guide to the selection of compaction equipment based on soil type.

FIGURE 5-10: Compaction equipment selection guide.

Material	Steel wheel	Pneumatic	Vibratory	Tamping foot	Grid
Rock	●	○	●	●	●
Gravel, clean or silty	●	◐	●	●	●
Gravel, clayey	●	◐	◐	●	◐
Sand, clean or silty	○	○	●	○	◐
Sand, clayey silt	○	◐	◐	●	○
Clay, sandy or silty	○	●	◐	●	○
Clay, heavy	○	●	◐	●	○

- Recommended
- ◐ Acceptable
- Marginal

Compaction Operations

- The major variables to be considered in the **compaction plan** include:
 1. Soil moisture content
 2. Lift thickness
 3. Number of passes used
 4. Ground contact pressure
 5. Compactor weight
 6. Compactor speed
- For vibratory compactors, it is also necessary to consider
 7. The frequency and amplitude of vibration to be employed.

Compaction Plan

- 1. soil moisture content
 - The compactive effort delivered by a piece of compaction equipment will seldom be exactly the same as that of either the standard or modified compaction test.
 - Thus, the field optimum moisture content for a particular soil/compactor combination will seldom be the same as the laboratory optimum.

FIGURE 5-11: Variation of optimum moisture content with roller type. (From reference 6)

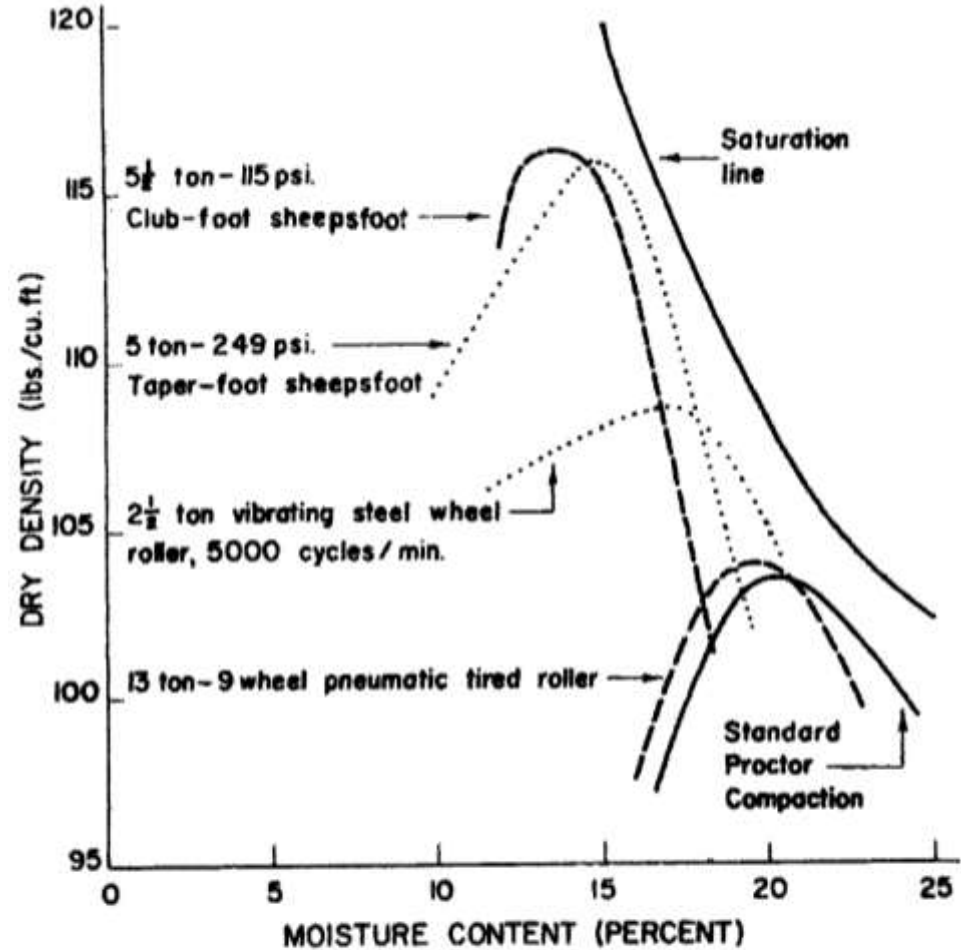

THE EFFECT OF MOISTURE CONTENT ON THE DRY DENSITY OF A SILTY CLAY (CL) SOIL IN 9 in. LOOSE LAYERS WHEN FULLY COMPACTED BY UP TO 64 PASSES BY DIFFERENT TYPES OF COMPACTING EQUIPMENT.

Compaction Plan

2. Lifts thicknesses :

- It should be kept thin for most effective compaction.
- For all rollers, except vibratory rollers and heavy pneumatic rollers, a maximum of 15 to 20 cm.
- The maximum lift thickness depends on the static weight of the compactor.

Compaction Plan

3. Number of passes

- The compaction achieved by repeated passes of a compactor depends on the soil/compactor combination utilized.
- For some combinations (such as a tamping foot roller compacting a clayey gravel), significant increases in density may continue to occur beyond 50 passes.

FIGURE 5-12: Typical effect of number of passes.

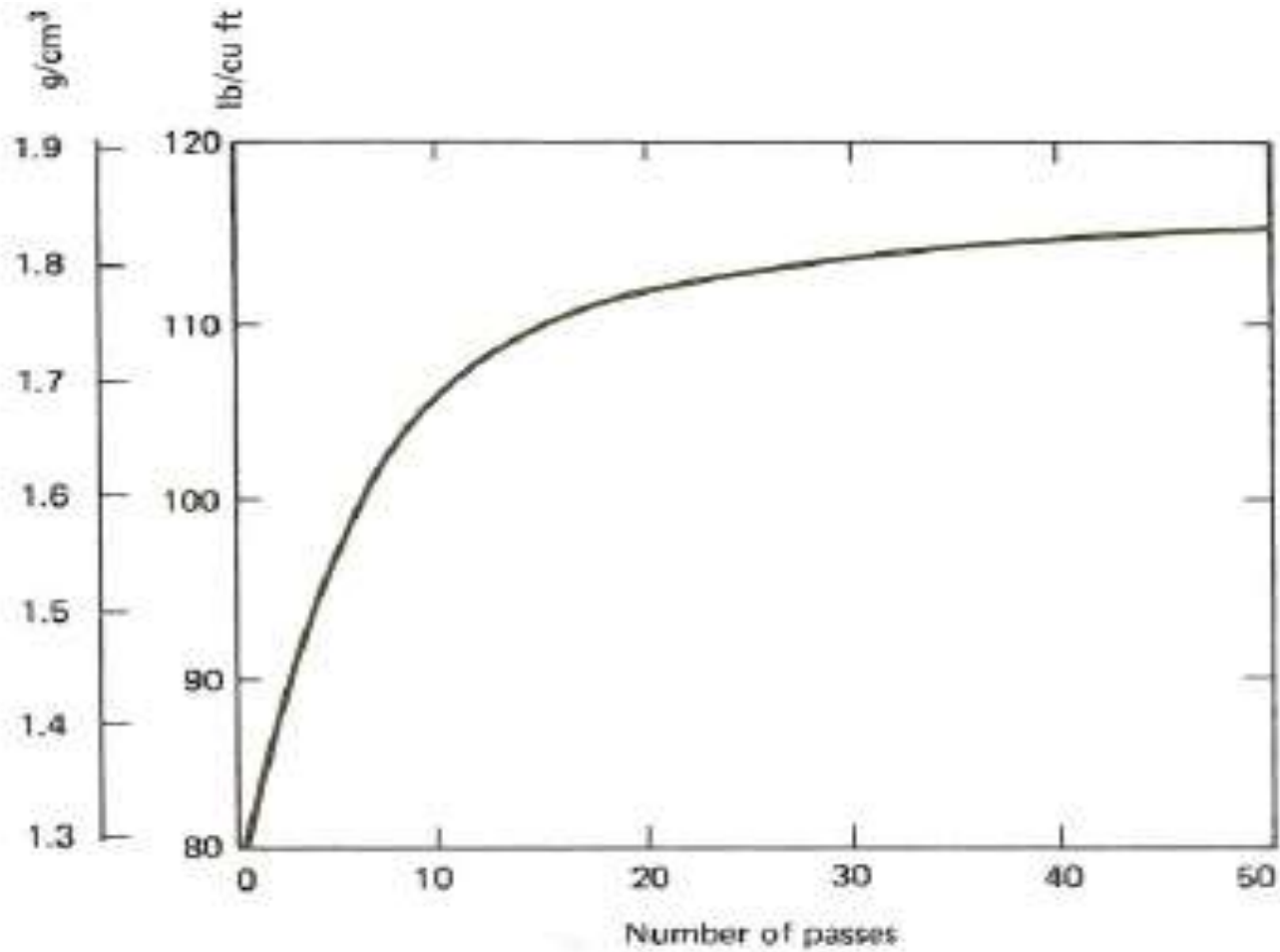

Compaction Plan

- 4. Ground contact pressure
 - Ground contact pressure may vary from:
 - 30 lb/sq in. (207 kPa) for a pneumatic roller to
 - 300 lb/sq in. (2070 kPa) or more for tamping foot rollers.
 - Within these ranges it has been found that:
 - total roller weight has a much more pronounced effect on the compaction achieved than does contact pressure.
 - The use of excessive ground contact pressure will result in **shearing and displacement** of the soil being compacted.

Compaction Plan

- **6. Compactor speed**

- Tests have shown little relationship between compactor travel speed and the compaction achieved, except for vibratory compactors.
- For **conventional equipment** the highest possible speed should be utilized that does not result in excessive surface displacement.

Estimating Compactor Production

- Compactor production depends upon
 - Compactor speed
 - Lift thickness
 - Effective width of compaction
 - Number of passes required

TABLE 5-3: Typical operating speed of compaction equipment

Compactor	Speed	
	<i>mi/h</i>	<i>km/h</i>
Tamping foot, crawler-towed	3–5	5–8
Tamping foot, wheel-tractor-towed	5–10	8–16
High-speed tamping foot		
First two or three passes	3–5	5–8
Walking out	8–12	13–19
Final passes	10–14	16–23
Heavy pneumatic	3–5	5–8
Multitired pneumatic	5–15	8–24
Grid roller		
Crawler-towed	3–5	5–8
Wheel-tractor-towed	10–12	16–19
Segmented pad	5–15	8–24
Smooth wheel	2–4	3–6
Vibratory		
Plate	0.6–1.2	1–2
Roller	1–2	2–3

Estimating Compactor Production

$$\text{Production (CCM/h)} = 10 \times W \times S \times L \times E / P \quad (5-1)$$

Where

W = width compacted per pass (ft or m)

S = compactor speed (mi/h or km/h)

L = compacted lift thickness (in. or cm)

E = job efficiency

P = number of passes required

5-3 SOIL STABILIZATION

- *Soil stabilization* has been defined as:
 - The process of giving natural soils enough abrasive resistance and shear strength to accommodate traffic or loads.
- Soil stabilization methods include:
 - Mechanical methods
 - Hydraulic methods
 - Reinforcement methods
 - Physiochemical methods.

TABLE 5-4: Soil stabilization methods

Mechanical	Hydraulic	Reinforcement	Physiochemical
Compaction	Drainage	Confinement	Admixtures
Deep compaction	Preloading	Inclusions	Freezing
Vibroflotation	Electroosmosis	Minipiles	Grouting
		Soil nailing	Heating
		Stone columns	

- Deep compaction: dropping heavy weight (9-36 t) from a crane (15-30m) to increase the density of soil to a depth of up to 9 m.
- Vibroflotation: increasing density of cohesionless soil by inserting a vibratory probe into soil.
- Electroosmosis: employs electrical current to speed up the drainage of cohesive soils.

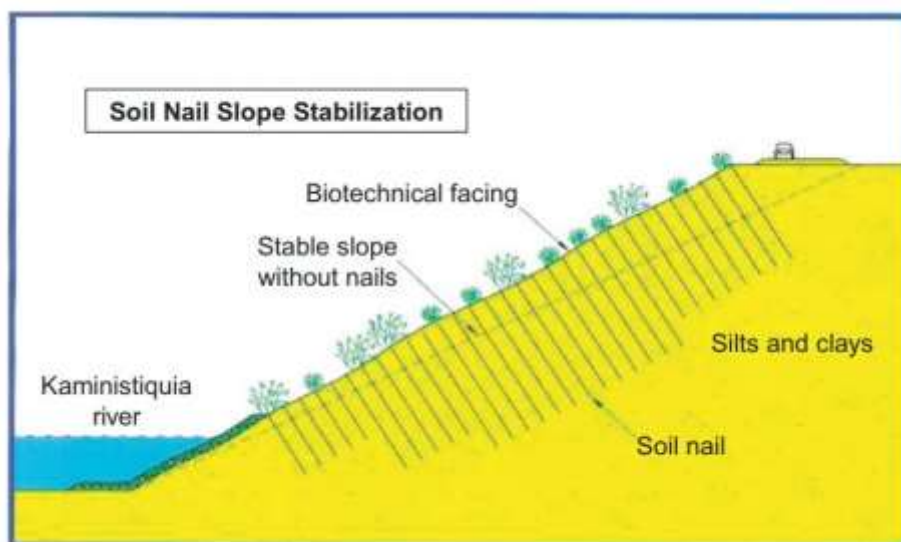

Figure 21.17 Soil nail and root solution for Kaministiquia riverbank slopes.

5-4 GRADING AND FINISHING

- *Grading* is the process of bringing earthwork to the desired shape and elevation (or grade).
- *Finish grading*, or simply *finishing*, involves smoothing slopes , shaping ditches, and bringing the earthwork to the elevation required by the plans and specification.
- Finishing usually follows closely behind excavation, compaction, and grading.
- Finishing is usually followed closely by seeding or sodding (grass) to control soil erosion.

Motor Grader

The piece of equipment most widely used for grading and finishing is the motor grader

Modern motor grader.

(Courtesy of Fiat allis North America, Inc.)

<https://youtu.be/qiqwsG4tjuY?t=27>

<https://www.youtube.com/watch?v=bFoN5LD0Q-w>

https://www.youtube.com/watch?v=ZNWafIsqI_g



Motor Grader

- The *motor grader* is one of the most versatile items of earthmoving equipment.
 - It can be used for light stripping , grading ,finishing, trimming , bank sloping, ditching, backfilling, and scarifying.
 - It is capable of mixing and spreading soil and asphaltic mixtures.
 - It is used on building construction projects as well as in heavy and highway construction.
 - It is frequently used for the maintenance of highways and haul roads.

- The blade of a motor grader is referred to as a *moldboard* and is equipped with replaceable cutting edges and end pieces (end bits).
- The wide range of possible blade positions is illustrated below

FIGURE 5-15: Blade positions for the motor grader.

(U.S. Department of the Army)

<https://www.youtube.com/watch?v=S1GskljGjsg>

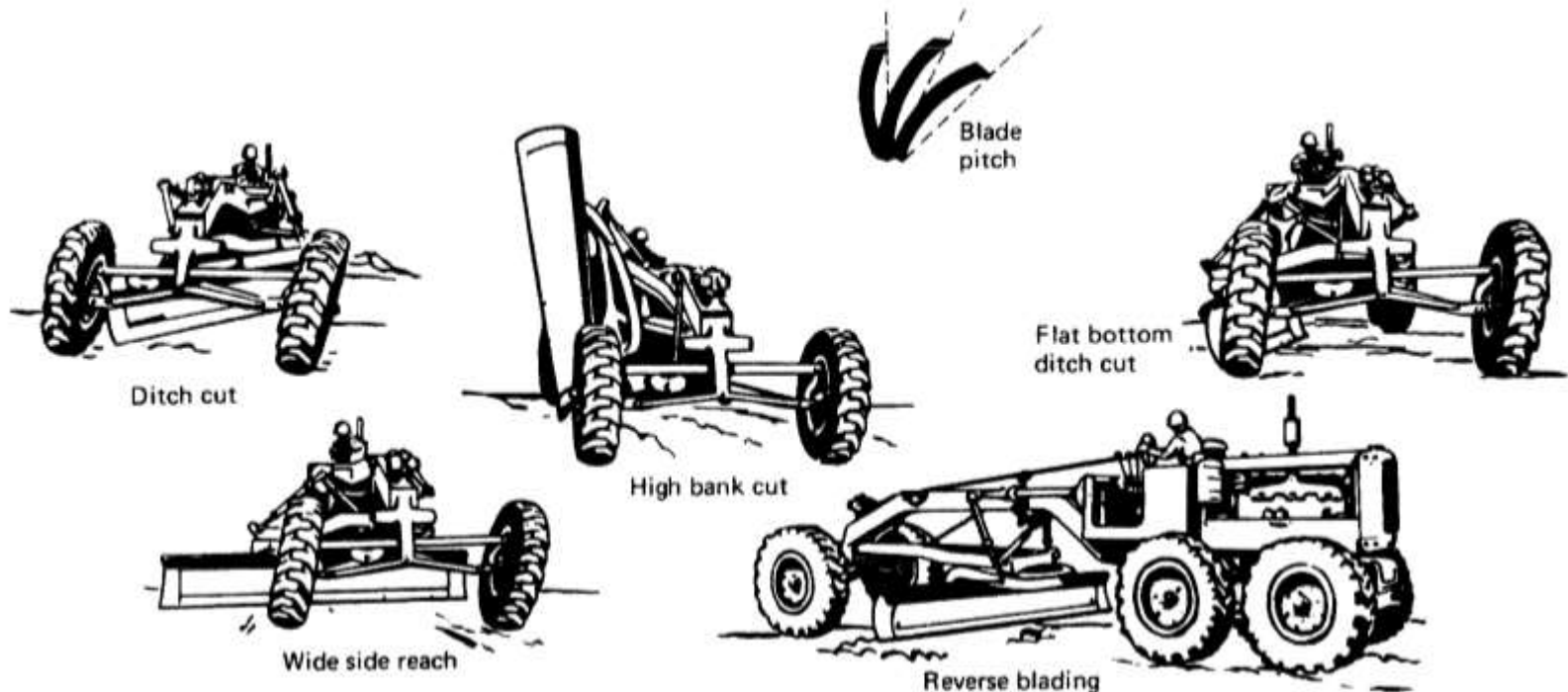

- Motor graders are available with articulated frames that increase grader maneuverability.
- The three possible modes of operation for an articulated grader are illustrated below
- <https://www.youtube.com/watch?v=JQXaW2svM7w>

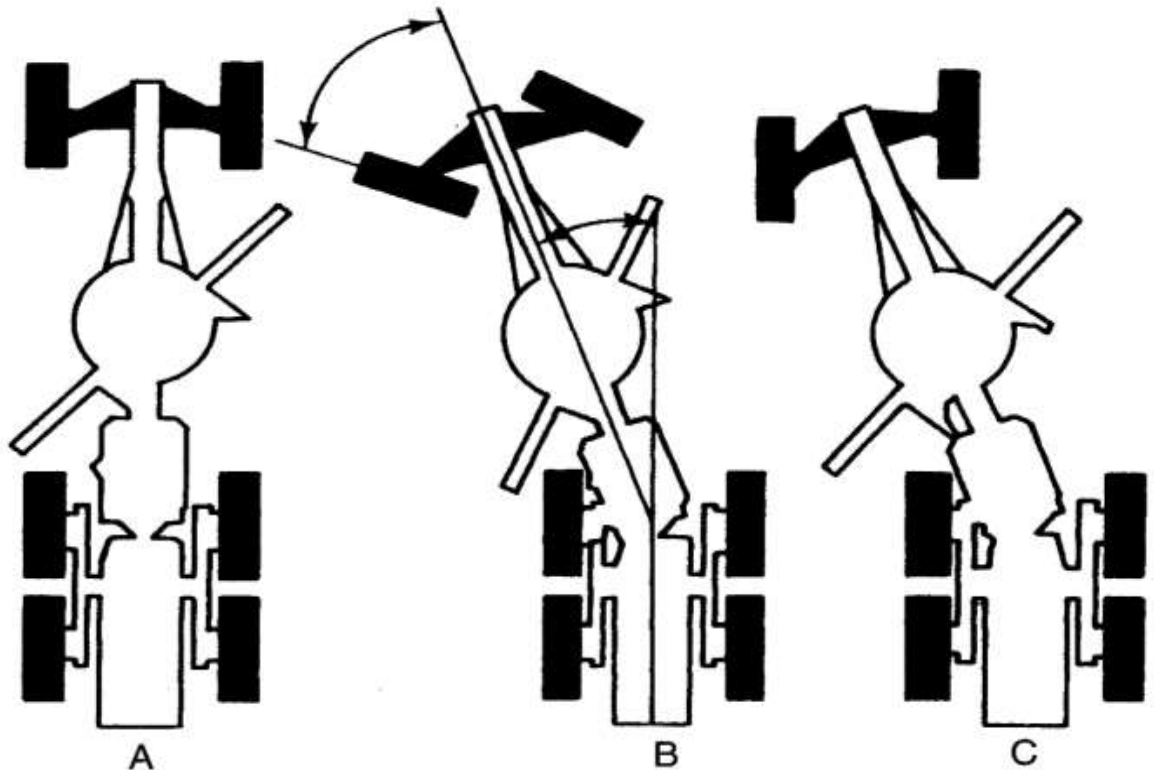

- The machine operation modes are:
 - **Conventional manner (A)** machine in the straight mode.
 - **Articulated mode (B)** to allow the machine to turn in a short radius.
 - **The crab mode (C)** permits the rear driving wheels to be offset so that they remain on firm ground while the machine cuts banks, side slopes, or ditches.

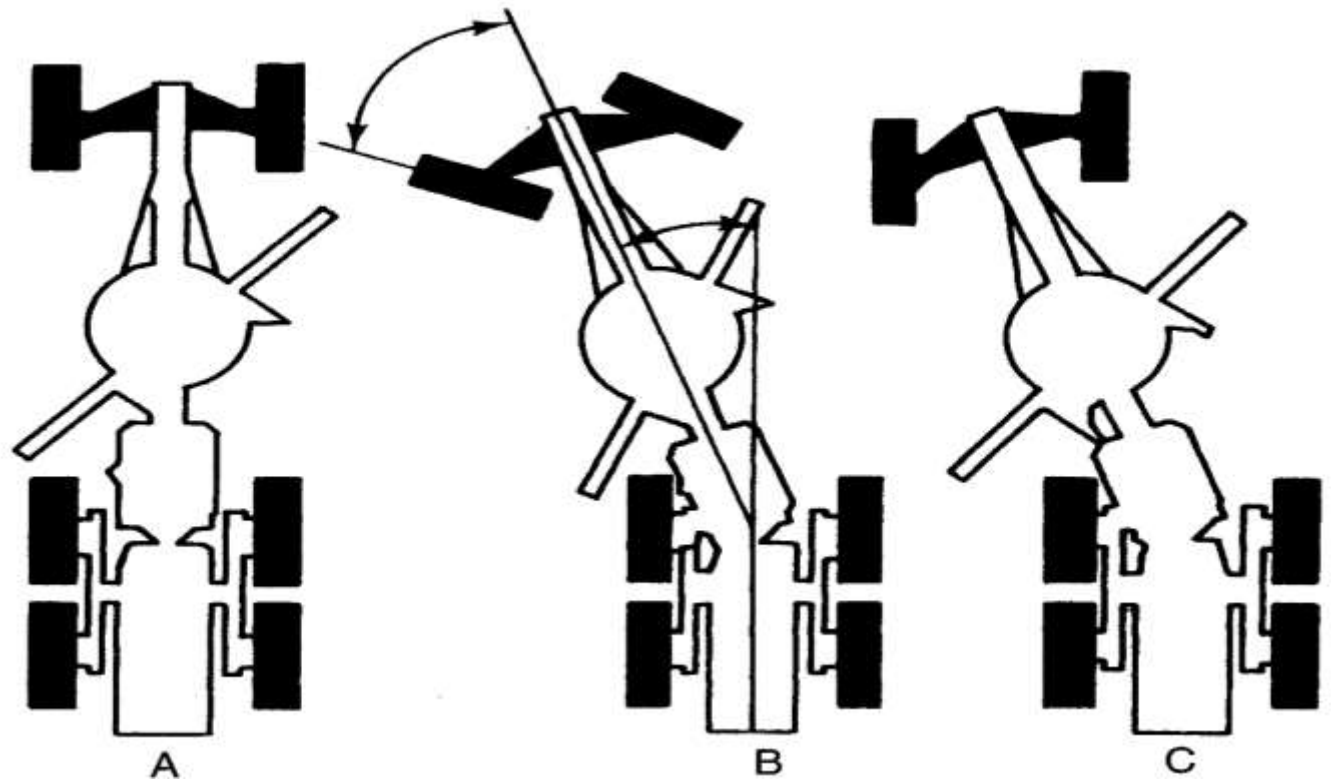

Motor Grader

- The front wheels of both conventional and articulated graders may be **leaned from side to side**.
- Wheels are leaned away from the cut to offset the side thrust produced by soil pressure against the angled blade also to assist in turning the grader (**bracing**).

side thrust

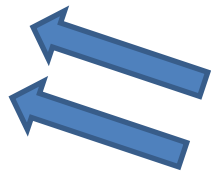

Grade Excavators and Trimmers

- In highway construction
 - the process of cutting down high spots and filling in low spots of each roadway layer is called *Balancing*
 - *Trimming* is the process of bringing each roadway layer to its final grade.
- Grade trimmers and excavators are frequently used on large highway and airfield projects because their operating speed is greater than that of the motor grader.

FIGURE 5-17: Large grade trimmer/reclaimer/paver.
(Courtesy of CMI Corp.)



Grade Excavators and Trimmers

Grade excavators or trimmers:

- They are machines that are capable of finishing roadway and airfield subgrades and bases faster and more accurately than can motor graders.
- Many of these machines also act as reclaimers.
- They are capable of scarifying and removing soil and old asphalt pavement.
- They lack the versatility of motor graders.
- They are very useful on large roadway and airfield projects because of their accuracy and high speed.
- Their large size often requires that they be partially disassembled and transported between job sites on heavy equipment trailers.

Estimating Grader Production

- Grader production is usually calculated:
 - on a linear basis that is kilometers completed per hour for roadway projects
 - on an area basis that is square meters per hour for general construction projects.
- The time required to complete a roadway project may be estimated as follows:

$$\text{Time (h)} = \left[\sum \frac{\text{Number of passes} \times \text{Section length (mi or km)}}{\text{Average speed for section (mi/h or km/h)}} \right] \times \frac{1}{\text{Efficiency}} \quad (5-2)$$

- Average speed of a grader depends on operator skill, machine characteristics, and job conditions.
- Typical grader speeds for various types of operations are given in the Table below

TABLE 5-6: Typical grader operating speed

Operation	Speed	
	<i>mi/h</i>	<i>km/h</i>
Bank sloping	2.5	4.0
Ditching	2.5–4.0	4.0–6.4
Finishing	4.0–9.0	6.5–14.5
Grading and road maintenance	4.2–6.0	6.4–9.7
Mixing	9.0–20.0	14.5–32.2
Snow removal	12.0–20.0	19.3–32.3
Spreading	6.0–9.0	9.7–14.5

EXAMPLE 5-1

24.1 km of gravel road require reshaping and leveling. You estimate that six passes of a motor grader will be required. Based on operator skill, machine characteristics, and job conditions, you estimate two passes at 6.4 km/h, two passes at 8.0 km/h, and two passes at 9.7 km/h. If job efficiency is 0.80, how many grader hours will be required for this job?

Solution

$$\text{Time (h)} = ((2 \times 24.1 / 6.4) + (2 \times 24.1 / 8.0) + (2 \times 24.1 / 9.7)) \times 1 / 0.8 = 23.1 \text{ h}$$