

Chapter 4

Loading and Hauling

Part 1



4-1 ESTIMATING EQUIPMENT TRAVEL TIME

- **Cycle time = Fixed time + Variable time (4-1)**
- *Fixed time* represents those components of cycle time other than travel time. It includes:
 - spot time (moving the unit into position to begin loading),
 - load time,
 - maneuver time, and
 - dump time.
- Fixed time can usually be closely estimated for a particular type of operation.

- *Variable time* represents the travel time required for a unit to haul material to the unloading site and return.
- It depends on:
 - 1. the vehicle's weight and power,
 - 2. the condition of the haul road,
 - 3. the grades encountered, and
 - 4. the altitude above sea level.

-2.condition of the haul road,

Rolling Resistance

- It is used to determine the maximum speed of a vehicle in a specific situation.
- The resistance that a vehicle encounters in traveling over a surface is made up of two components:
 - rolling resistance and
 - grade resistance.
- **Total resistance =**
Grade resistance + Rolling resistance (4-2)

Rolling Resistance

- Resistance may be expressed in either:
 - kilograms per metric ton of vehicle weight (**resistance factor**)
 - Kilograms (**resistance**)
- To avoid confusion, the term *resistance factor* will be used in this chapter to denote resistance in kg/t.
- *Rolling resistance* is primarily due to:
 - tire flexing and
 - penetration of the travel surface.

Rolling resistance is a force resisting movement.

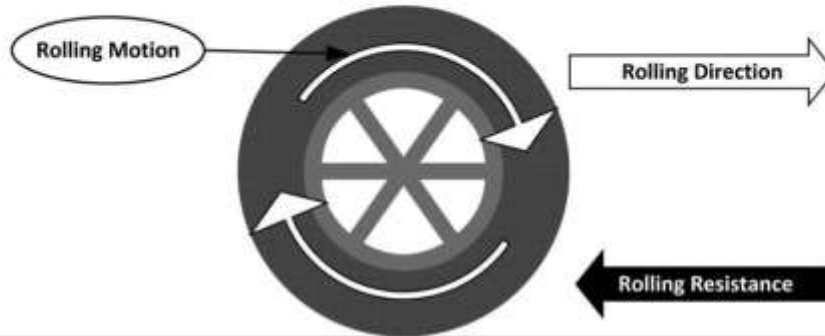

Contributions to rolling resistance

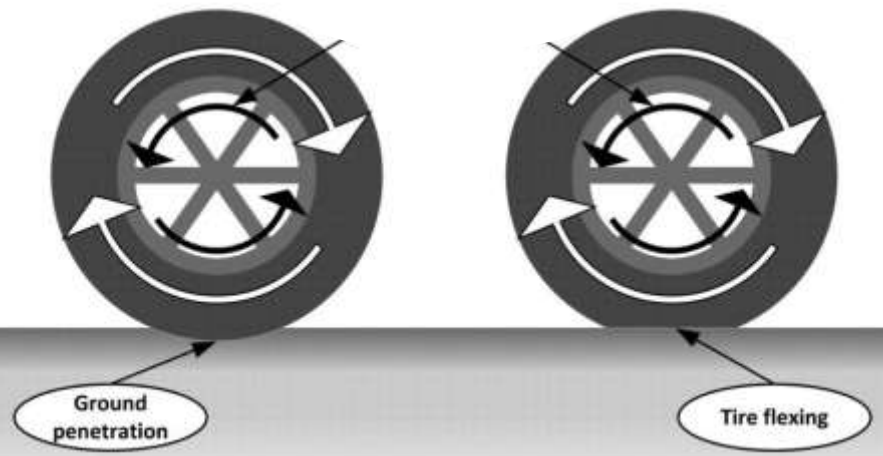

Rolling Resistance

- The rolling resistance factor:
 - for a rubber-tired vehicle equipped with conventional tires moving over a hard, smooth, level surface = 20 kg/t of vehicle weight.
 - For vehicles equipped with radial tires, the rolling resistance factor = 15 kg/t.
 - It increases about 6 kg/t for each 1 cm of tire penetration.

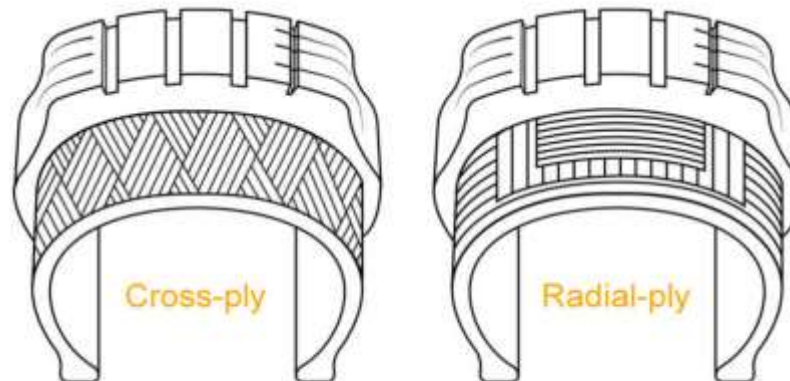

Rolling Resistance

- This leads to the following equation for estimating rolling resistance factors:
 - Rolling resistance factor (kg/t) =
$$20 + (6 \times \text{cm penetration}) \quad (4-3B)$$

Rolling Resistance

- The rolling resistance in kilograms
= Rolling resistance factor × the vehicle's
weight in metric tons.
- Table 4-1 provides typical values for the rolling
resistance factor in construction situations.

TABLE 4-1 Typical values of rolling resistance factor

Type of Surface	Rolling Resistance Factor	
	lb/ton	kg/t
Concrete or asphalt	40 (30)*	20 (15)
Firm, smooth, flexing slightly under load	64 (52)	32 (26)
Rutted dirt roadway, 1–2 in. penetration	100	50
Soft, rutted dirt, 3–4 in. penetration	150	75
Loose sand or gravel	200	100
Soft, muddy, deeply rutted	300–400	150–200

*Values in parentheses are for radial tires.

Rolling Resistance

- Crawler tractors may be thought of as traveling over a road created by their own tracks.
 - As a result, crawler tractors are usually considered to have *no rolling resistance* when calculating vehicle resistance and performance.
- The rolling resistance of crawler tractors does vary somewhat between different surfaces.

Rolling Resistance

- The standard method for rating crawler tractor power (drawbar horsepower) measures the power actually produced at the hitch when operating on a standard surface.
 - Thus, the rolling resistance of the tractor over the standard surface has already been subtracted from the tractor's performance.
- The rolling resistance of the towed *wheeled* vehicle must be considered in calculating the total resistance of the combination.

This is where the driver's seat is. Some types have a roof only, and others have a room like this one.



Blade

This part is used to push soil and rocks, and level the ground.

Crawler

With this crawler, bulldozers can move even on rough surfaces. Some crawlers can move on muddy surfaces too.



Ripper

The sharp ripper at its bottom can dig up the ground.

3. The grades encountered

Grade Resistance

- *Grade resistance* represents that component of vehicle weight which acts parallel to an inclined surface.
 - When the vehicle is traveling up a grade, grade resistance is positive.
 - When traveling downhill, grade resistance is negative.

Grade Resistance

$$\frac{V}{I} = \sin \theta \approx \tan \theta = \frac{V}{H} = \frac{G}{100}$$

$$W_G = W \tan \theta = W \left(\frac{G}{100} \right)$$

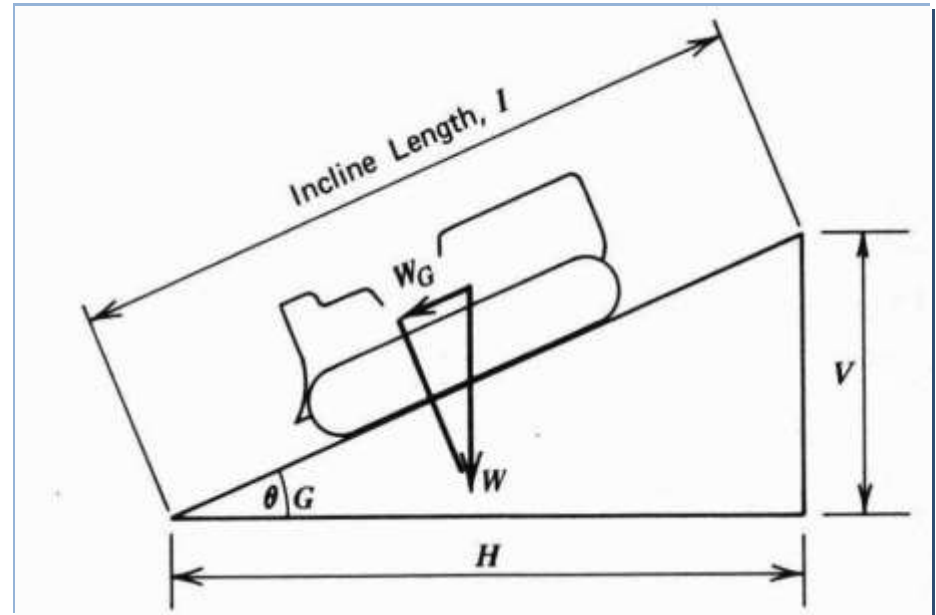

$$\frac{5}{100} \times 100 = 5\%$$

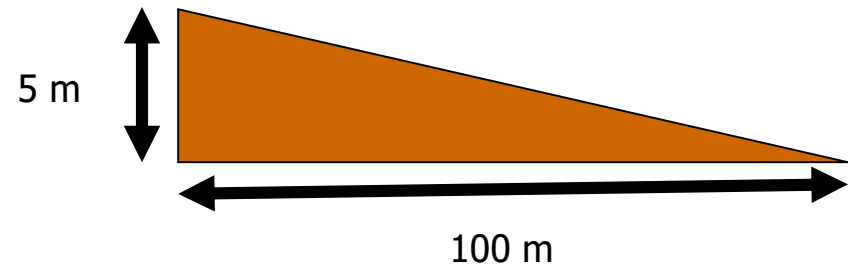

Grade Resistance

- The exact value of grade resistance may be found by multiplying the vehicle's weight by the sine of the angle that the road surface makes with the horizontal.
- That is, a 1% grade (representing a rise of 1 unit in 100 units of horizontal distance) is considered to have a grade resistance equal to 1% of the vehicle's weight.
- $$W_G = W \tan \theta = W \left(\frac{G}{100} \right)$$

- For the grades usually encountered in construction, it is sufficiently accurate to use the approximation of Equation 4-4.
 - Grade resistance factor (kg/t) = $10 \times \text{grade (\%)}$ (4-4B)
 - This corresponds to a grade resistance factor of 10 kg/t for each 1% of grade,

Grade Resistance

- Grade resistance (kg) may be calculated using Equation 4-5 or 4-6.
 - Grade resistance (kg) =
Vehicle weight (t) × Grade resistance factor (kg/t) (4-5B)
 - Grade resistance (kg) = Vehicle weight (kg) × Grade (4-6B)

$$W_G = W \tan \theta = W \left(\frac{G}{100} \right)$$

Effective Grade

- The total resistance to movement of a vehicle (*the sum of its rolling resistance and grade resistance*) might be **expressed in kilograms**.
- OR **expressed as a grade (%)**, A grade resistance equivalent to total resistance actually encountered.

Effective Grade

- Effective grade may be easily calculated by use of Equation 4-7.

– Effective grade (%) =

Grade (%) + Rolling resistance factor (kg/t) / 10

(4-7B)

EXAMPLE 4-1

- A wheel tractor-scraper weighing 91 t is being operated on a haul road with a tire penetration of 5 cm.
- What is the total resistance (kg) and effective grade when
 - (a) the scraper is ascending a slope of 5%;
 - (b) the scraper is descending a slope of 5%?



EXAMPLE 4-1

- **Solution**

$$\text{Rolling resistance factor} = 20 + (6 \times 5) = 50 \text{ kg/t}$$

$$\text{Rolling resistance} = 50 \text{ (kg/t)} \times 91 \text{ (t)} = 4550 \text{ kg}$$

$$\text{Grade resistance (kg)} = \text{Vehicle weight (kg)} \times \text{Grade} \quad (4-6B)$$

$$\text{a) Grade resistance} = 91 \text{ (t)} \times 1000 \text{ (kg/t)} \times 0.05 = 4550 \text{ kg}$$

$$\text{Total resistance} = 4550 \text{ kg} + 4550 \text{ kg} = 9100 \text{ kg}$$

$$\text{Effective grade} = 5 + 50/10 = 10\%$$

$$\text{(b) Grade resistance} =$$

$$= 91 \text{ (t)} \times 1000 \text{ (kg/t)} \times (-0.05) = -4550 \text{ kg}$$

$$\text{Total resistance} = -4550 \text{ kg} + 4550 \text{ kg} = 0 \text{ kg}$$

$$\text{Effective grade} = -5 + 50/10 = 0\%$$

EXAMPLE 4-2

- A crawler tractor weighing (36 t) is towing a rubber-tired scraper weighing (45.5 t) up a grade of 4%. What is the total resistance (kg) of the combination if the rolling resistance factor is (50 kg/t)?



EXAMPLE 4-2

- **Solution**

Rolling resistance (neglect crawler) =

$$= 45.5 \text{ (t)} \times 50 \text{ (kg/t)} = 2275 \text{ kg}$$

– Grade resistance (kg) =

$$\text{Vehicle weight (t)} \times \text{Grade resistance factor (kg/t)} \quad (4-5B)$$

– Grade resistance (kg) = Vehicle weight (kg) x Grade (4-6B)

Total vehicle weight = 36 (tractor) + 45.5 (scraper) = 81.5 t

$$\text{Grade resistance} = 81.5 \times 1000 \text{ kg/t} \times 0.04 = 3260 \text{ kg (4-6B)}$$

$$\text{Total resistance} = 2275 + 3260 = 5535 \text{ kg (4-2)}$$

Effect of Altitude

- All internal combustion engines lose power as their elevation above sea level increases because of the **decreased density of air** at higher elevations.
- Internal combustion engines normally deliver full rated power up to an altitude of **915 m (3000 ft)**.
- Engine power decreases approximately **3%** for each **305 m (1000 ft)** above maximum altitude for rated performance.

- Turbocharged engines are more efficient at higher altitude than are naturally aspirated engines and may deliver full rated power up to an altitude of **3050** m (10000 ft) or more.

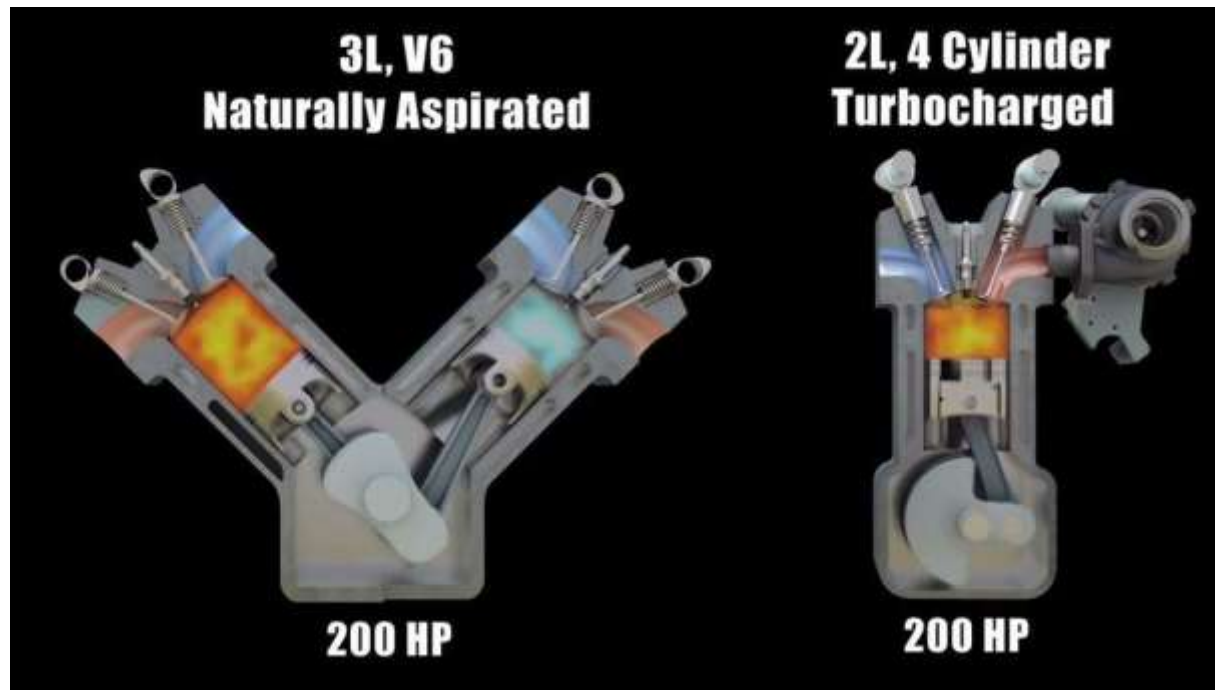

- When derating tables are not available,
 - the derating factor obtained by the use of Equation 4-8 is sufficiently accurate for estimating the performance of naturally aspirated engines.
 - Derating factor (%) = $(\text{Altitude (m)} - 915^*)/102$ (4-8B)
- *Substitute maximum altitude for rated performance, if known.
- The percentage of rated power available
= 100 - the derating factor.

Effect of Traction

- The **power available** to move a vehicle and its load is expressed as :
 - *rimpull* for wheel vehicles and
 - *drawbar pull* for crawler tractors.

Effect of Traction

- Rimpull is :
 - the pull available at the rim of the **driving wheels** under rated conditions.
 - Also, the power available at the surface of the tires.

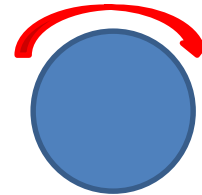

- Drawbar pull is :
 - the power available at the hitch of a crawler tractor operating under standard conditions.

Maximum Usable Pull

- Factors affect maximum pull of Vehicle are:
 - a) Operation at increased altitude may reduce the maximum pull of a vehicle,
 - b) the maximum **traction** that can be developed between the driving wheels or tracks and the road surface.

Maximum Usable Pull

Maximum usable pull = Coefficient of traction × Weight on drivers
(4-9)

- This represents the maximum pull that a vehicle can develop, **regardless of vehicle horsepower**
- Weight on drivers:
 - for crawler tractors and all-wheel-drive rubber-tired equipment, the weight on the drivers is the total vehicle weight.

TABLE 4-2: Typical values of coefficient of Traction

Type of Surface	Rubber Tires	Tracks
Concrete, dry	0.90	0.45
Concrete, wet	0.80	0.45
Earth or clay loam, dry	0.60	0.90
Earth or clay loam, wet	0.45	0.70
Gravel, loose	0.35	0.50
Quarry pit	0.65	0.55
Sand, dry, loose	0.25	0.30
Sand, wet	0.40	0.50
Snow, packed	0.20	0.25
Ice	0.10	0.15

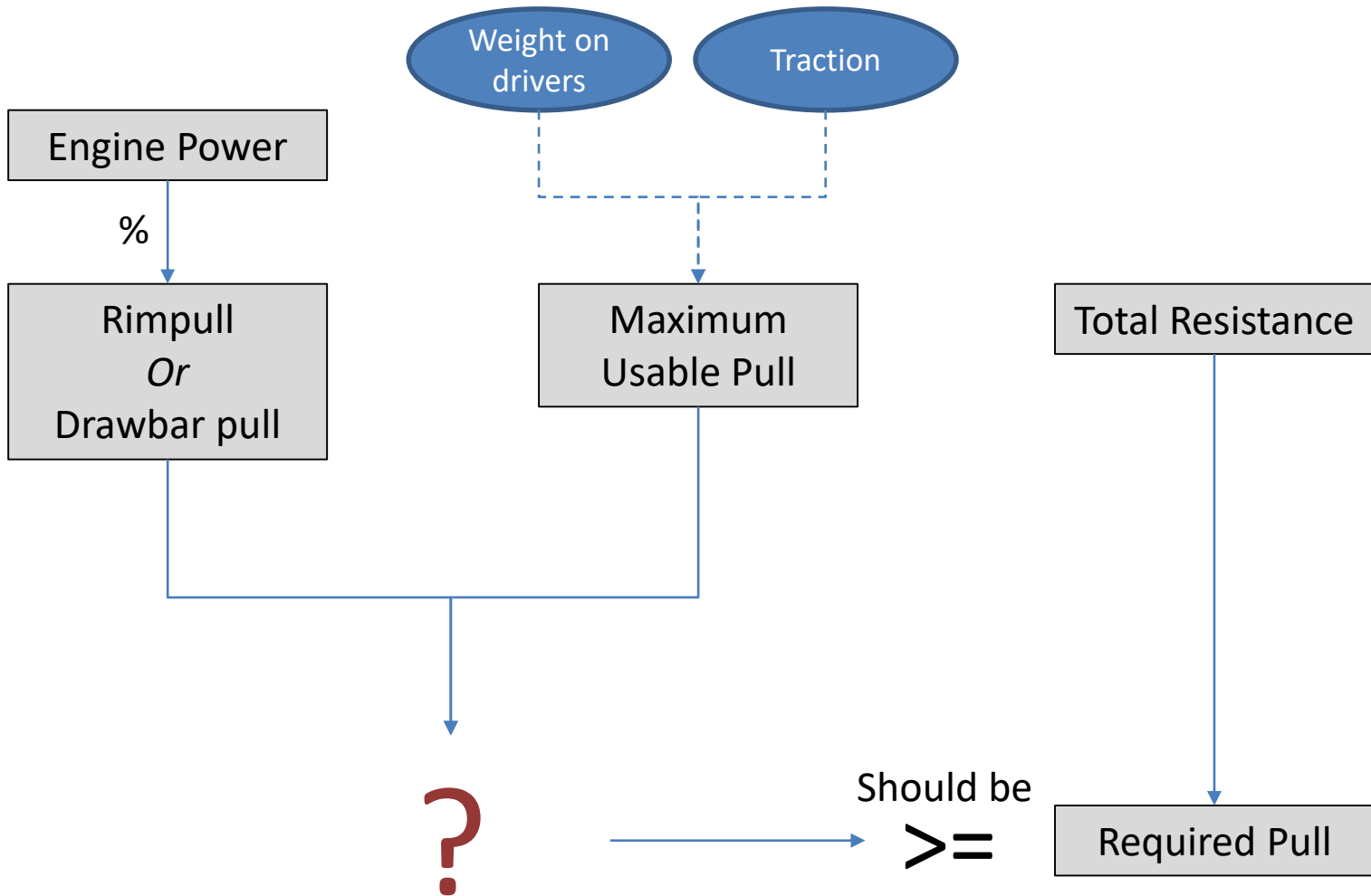

EXAMPLE 4-3

- A four-wheel drive tractor weighs (20000 kg) and produces a maximum rimpull of (18160 kg) at sea level.
- The tractor is being operated at an altitude of (3050 m) on wet earth.
- A pull of (10000 kg (total resistance)) is required to move the tractor and its load.
- Can the tractor perform under these conditions?
 - Use Equation 4-8 to estimate altitude deration.

• Solution

Derating factor = $(3050 - 915)/102 = 21\%$ (4-8B)

Percent rated power available = $100 - 21 = 79\%$

Maximum available power = $18160 \times 0.79 = 14346 \text{ kg}$

Coefficient of traction = 0.45 (Table 4-2)

Maximum usable pull = $0.45 \times 20000 = 9000 \text{ kg}$

- Because the maximum pull as limited by traction is less than the required pull, the tractor *cannot perform under these conditions*.
- For the tractor to operate, it would be necessary to:
 - reduce the required pull (total resistance),
 - increase the coefficient of traction, or
 - increase the tractor's weight on the drivers.



2016-09-25-VIDEO-0000663 (1).mp4

Use of Performance and Retarder Curves

- Crawler tractors may be equipped with direct-drive (manual gearshift) transmissions.
- The drawbar pull and travel speed of this type of transmission are **determined by the gear selected.**

FIGURE 4-1: Typical crawler tractor performance curve.

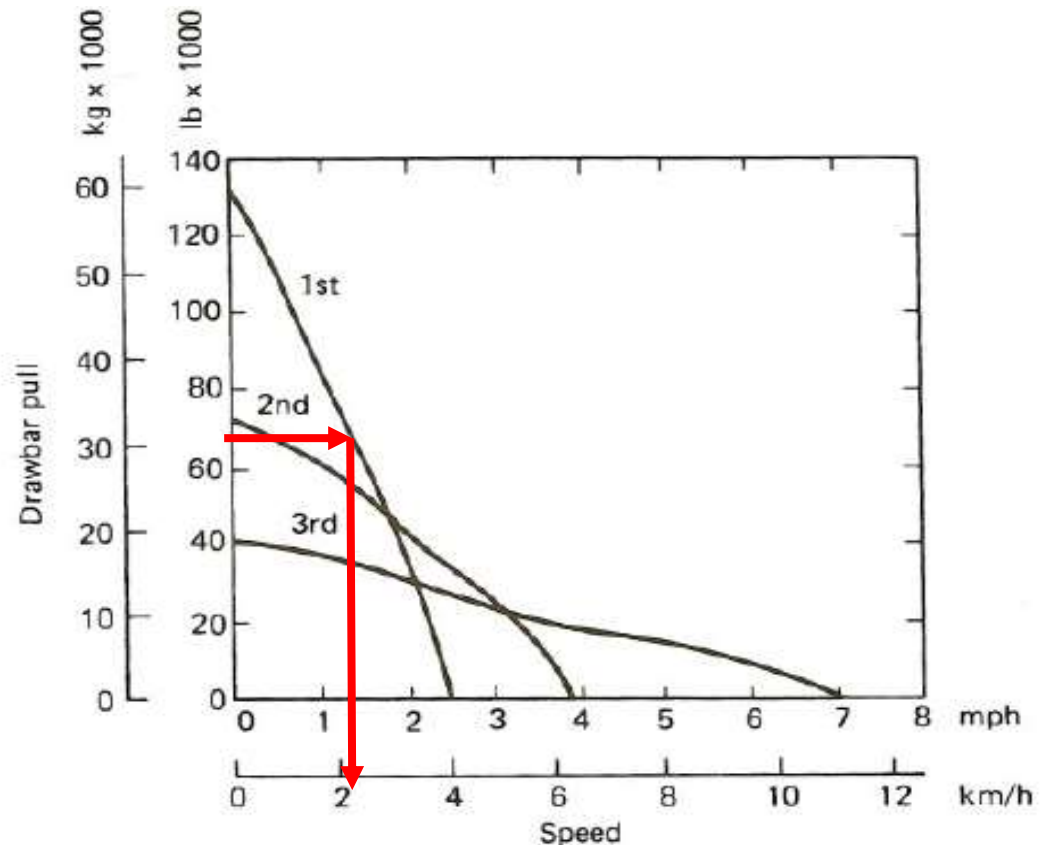

Use of Performance and Retarder Curves

For other types of transmissions and equipment, **speed versus pull** is represented using performance and retarder charts.

- *A performance chart:*
 - indicates the maximum speed that a vehicle can maintain under rated conditions while overcoming a specified total resistance.
- *A retarder chart:*
 - indicates the maximum speed at which a vehicle can descend a slope when the total resistance is negative without using brakes.
 - Retarder charts derive their name from the vehicle retarder, which is a hydraulic device used for controlling vehicle speed on a downgrade.

FIGURE 4-2: Wheel scraper performance curve. (Courtesy of Caterpillar Inc.)

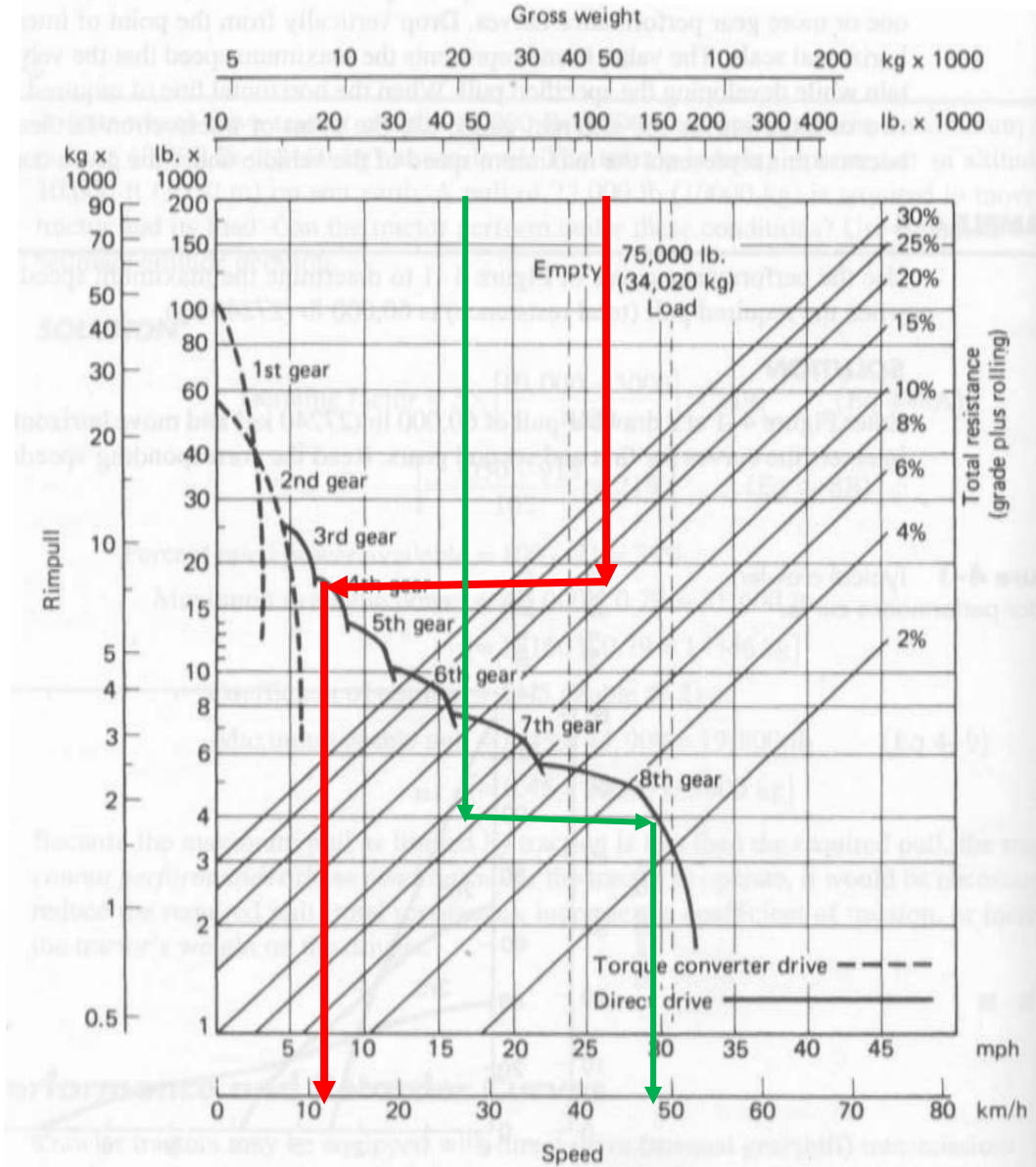
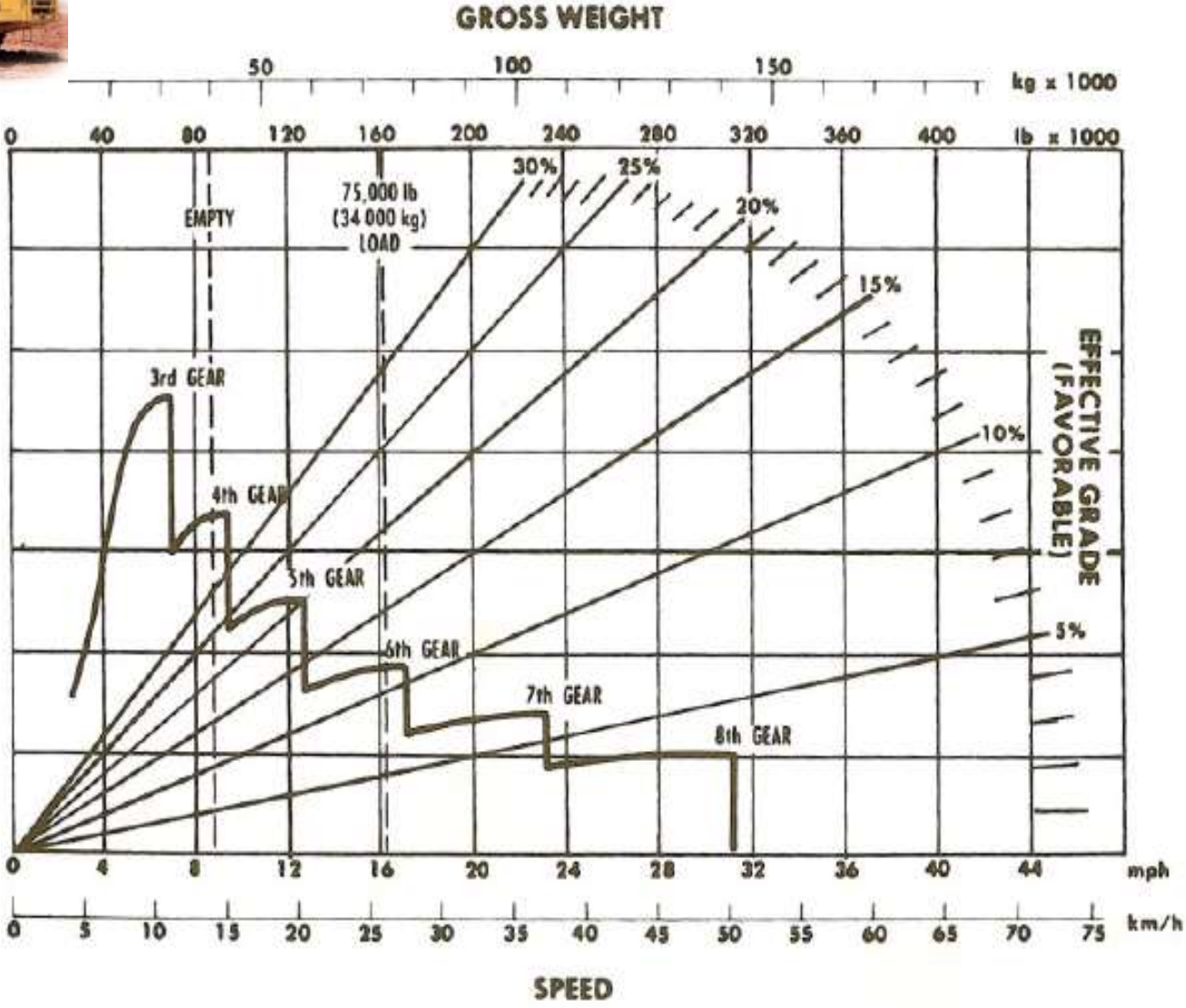

Figure 4-2 Wheel scraper performance curve. (Courtesy of Caterpillar Inc.)

FIGURE 4-3: Wheel scraper retarder curve.

(Courtesy of Caterpillar Inc.)



- Figure 4-1 illustrates a relatively simple performance curve of the type often used for crawler tractors.
 - Rimpull or drawbar pull is shown on the vertical scale and maximum vehicle speed on the horizontal scale.
 - The procedure for using this type of curve is to first calculate the **required pull** or **total resistance** of the vehicle and its load (lb or kg).
 - Then enter the chart on the vertical scale with the required pull and move horizontally until you intersect one or more gear performance curves.

FIGURE 4-1: Typical crawler tractor performance curve.

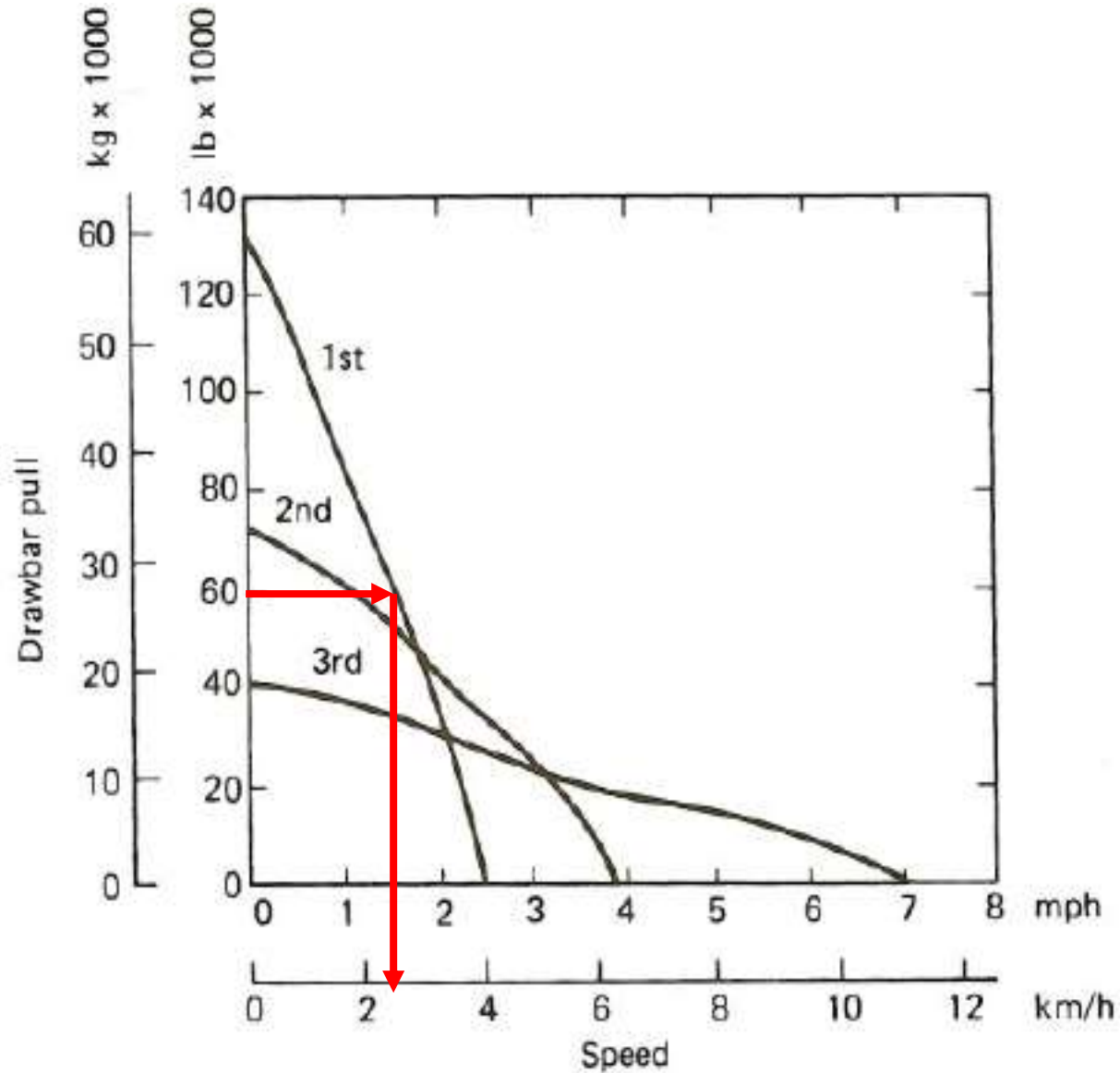

- Drop vertically from the point of intersection to the horizontal scale.
- The value found represents the maximum speed that the vehicle can maintain while developing the specified pull.
- When the horizontal line of required pull intersects two or more curves for different gears, use the point of intersection farthest to the right, because this represents the maximum speed of the vehicle under the given conditions.

EXAMPLE 4-4

- Use the performance curve of Figure 4-1 to determine the maximum speed of the tractor when the required pull (total resistance) is 60,000 lb (27240 kg).
- **Solution**
 - Enter Figure 4-1 at a drawbar pull of 60,000 lb (27240 kg) and move horizontally until you intersect the curves for first and second gears.
 - Read the corresponding speeds of 1.0 mi/h (1.6 km/h) for second gear and 1.5 mi/h (2.4 km/h) for first gear.
 - The maximum possible speed is therefore 1.5 mi/h (2.4 km/h) in first gear.

Use of Performance and Retarder Curves

- Figure 4-2 :
 - represents a more complex performance curve of the type frequently used by manufacturers of **tractor-scrapers, trucks, and wagons.**
 - This curve could be used for the followings:
 1. Speed versus pull,
 2. Provides a graphical method for calculating the required pull (total resistance).

FIGURE 4-2: Wheel scraper performance curve. (Courtesy of Caterpillar Inc.)

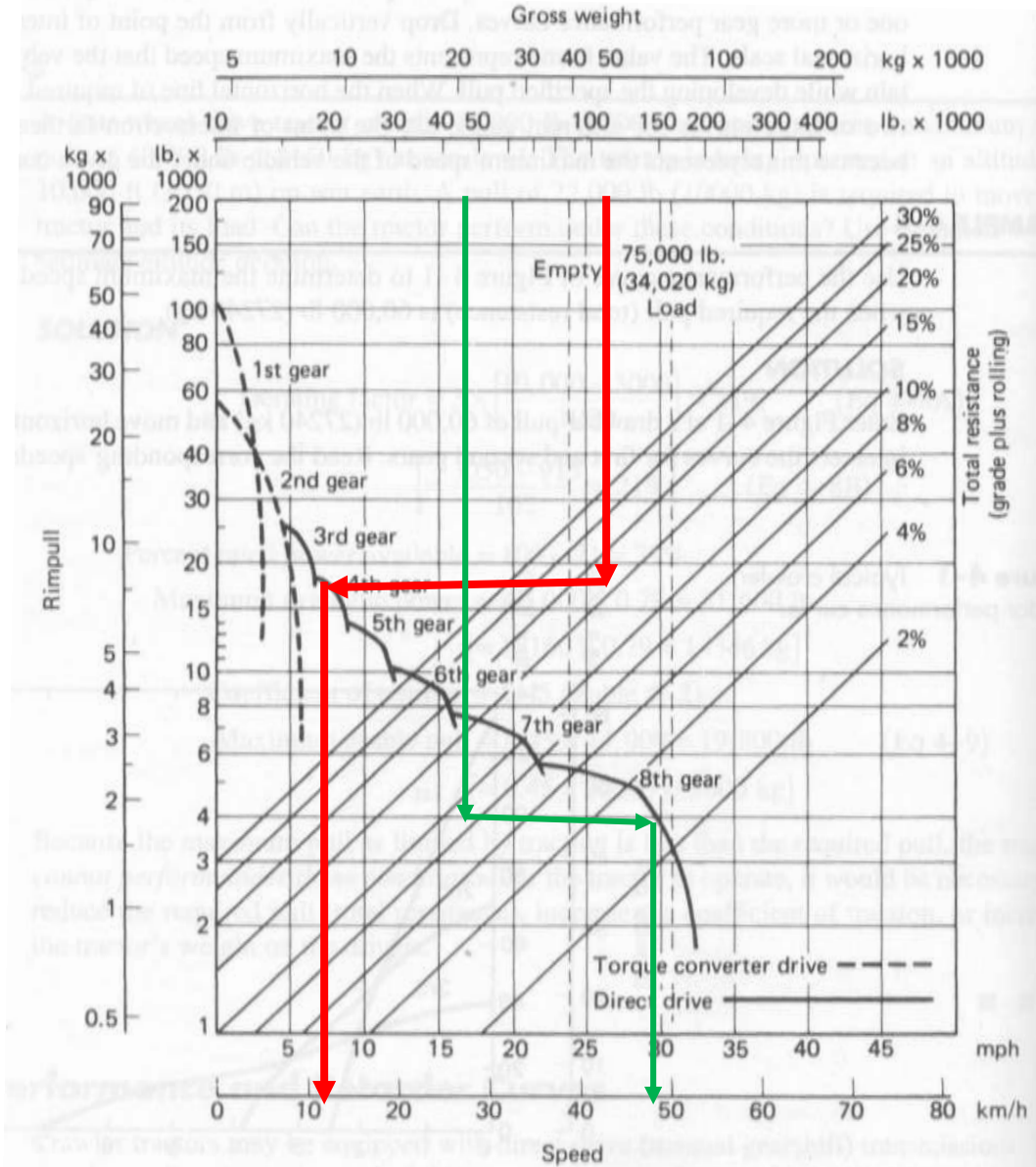

Figure 4-2 Wheel scraper performance curve. (Courtesy of Caterpillar Inc.)

Use of Performance and Retarder Curves

- To use this type of curve,
 - Enter the top scale at the actual weight of the vehicle (**empty or loaded as applicable**).
 - Drop vertically until you intersect the diagonal line corresponding to the percent total resistance (or effective grade), interpolating as necessary.
 - From this point **move horizontally** until you intersect one or more performance curves.
 - From the point of intersection, drop vertically to find the maximum vehicle speed.

Use of Performance and Retarder Curves

- When *altitude* adjustment is required, the procedure is modified slightly. In this case,
 - start with the gross weight on the top scale and drop vertically until you intersect the total resistance curve.
 - Move horizontally all the way to the left scale to read the required pull corresponding to vehicle weight and effective grade.

Use of Performance and Retarder Curves

- Next, divide the required pull by the quantity (1 - derating factor) (expressed as a decimal) to obtain an adjusted required pull.
- Now, from the adjusted value of required pull on the left scale move horizontally to intersect one or more gear curves and drop vertically to find the maximum vehicle speed.

Use of Performance and Retarder Curves

- This procedure is equivalent to saying that when a vehicle produces only one-half of its rated power due to altitude effects, its maximum speed can be found from its standard performance curve by doubling the actual required pull.
- The procedure is illustrated in Example 4-5.

EXAMPLE 4-5

- Using the performance curve of Figure 4-2, determine the maximum speed of the vehicle if :
 - its gross weight is 150,000 lb (68000 kg),
 - the total resistance is 10%, and
 - the altitude derating factor is 25%.

EXAMPLE 4-5

- **Solution**

- Start on the top scale with a weight of 150,000 lb (68000 kg), drop vertically to intersect the 10% total grade line, and move horizontally to find a required pull of 15,000 lb (6800 kg) on the left scale.

EXAMPLE 4-5

- Divide 15,000 lb (6800 kg) by 0.75 (1 - derating factor) to obtain an adjusted required pull of 20,000 lb (9080 kg).
- Enter the left scale at 20,000 lb (9080 kg) and move horizontally to intersect the first, second, and third gear curves.
- Drop vertically from the point of intersection with the third gear curve to find a maximum speed of 6 mi/h (10 km/h).

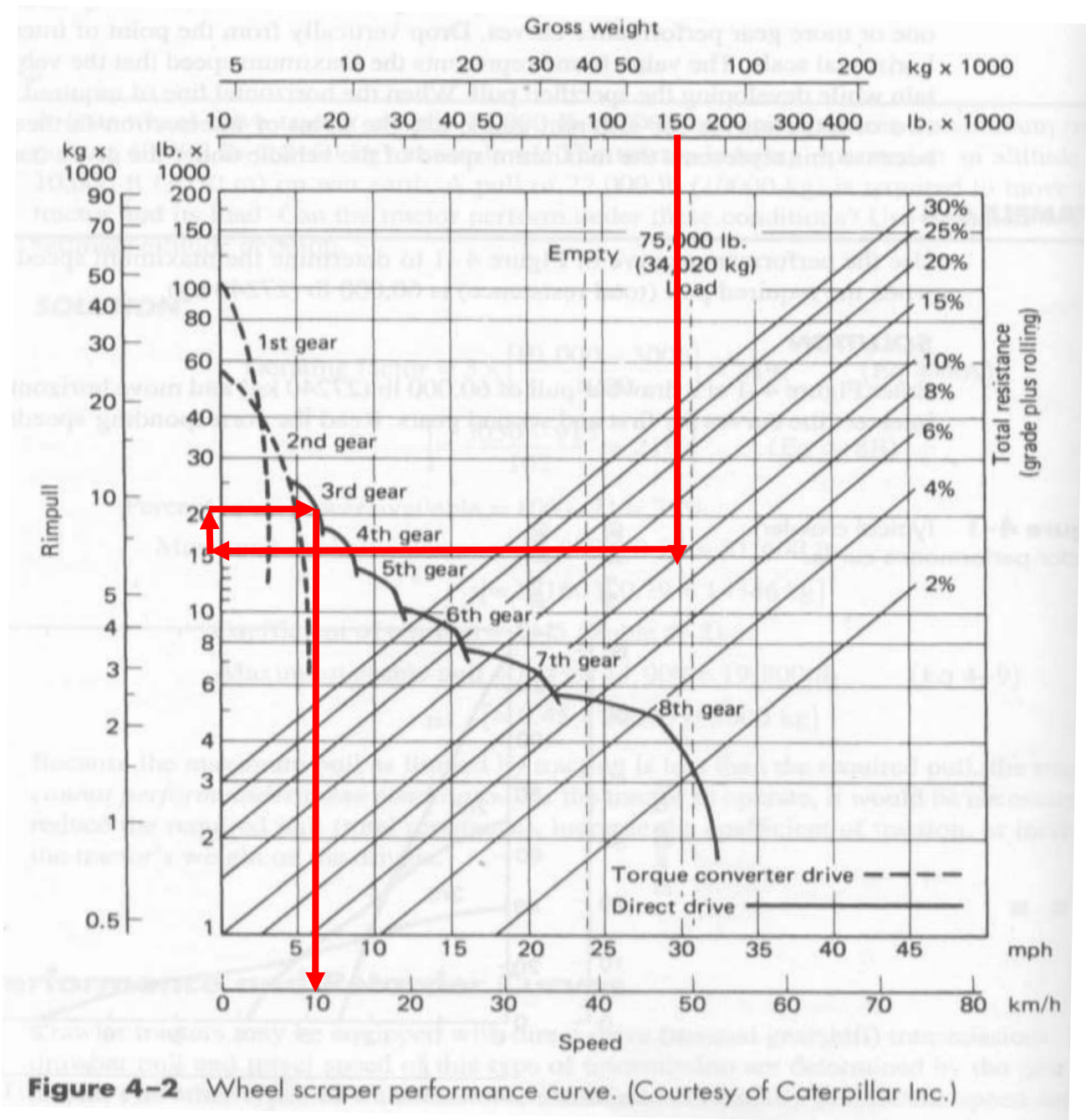

Figure 4-2 Wheel scraper performance curve. (Courtesy of Caterpillar Inc.)

Use of Performance and Retarder Curves

- Figure 4-3 illustrates a typical retarder curve.
 - In this case, it is the retarder curve for the tractor-scraper whose performance curve is shown in Figure 4-2.
 - The retarder curve is read in a manner similar to the performance curve.
 - Remember, however, that in this case the vertical scale represents *negative* total resistance.

Use of Performance and Retarder Curves

- After finding the intersection of the vehicle weight with effective grade,
 - move horizontally until you intersect the retarder curve.
 - Drop vertically from this point to find the maximum speed at which the vehicle should be operated.

FIGURE 4-3: Wheel scraper retarder curve.
 (Courtesy of Caterpillar Inc.)

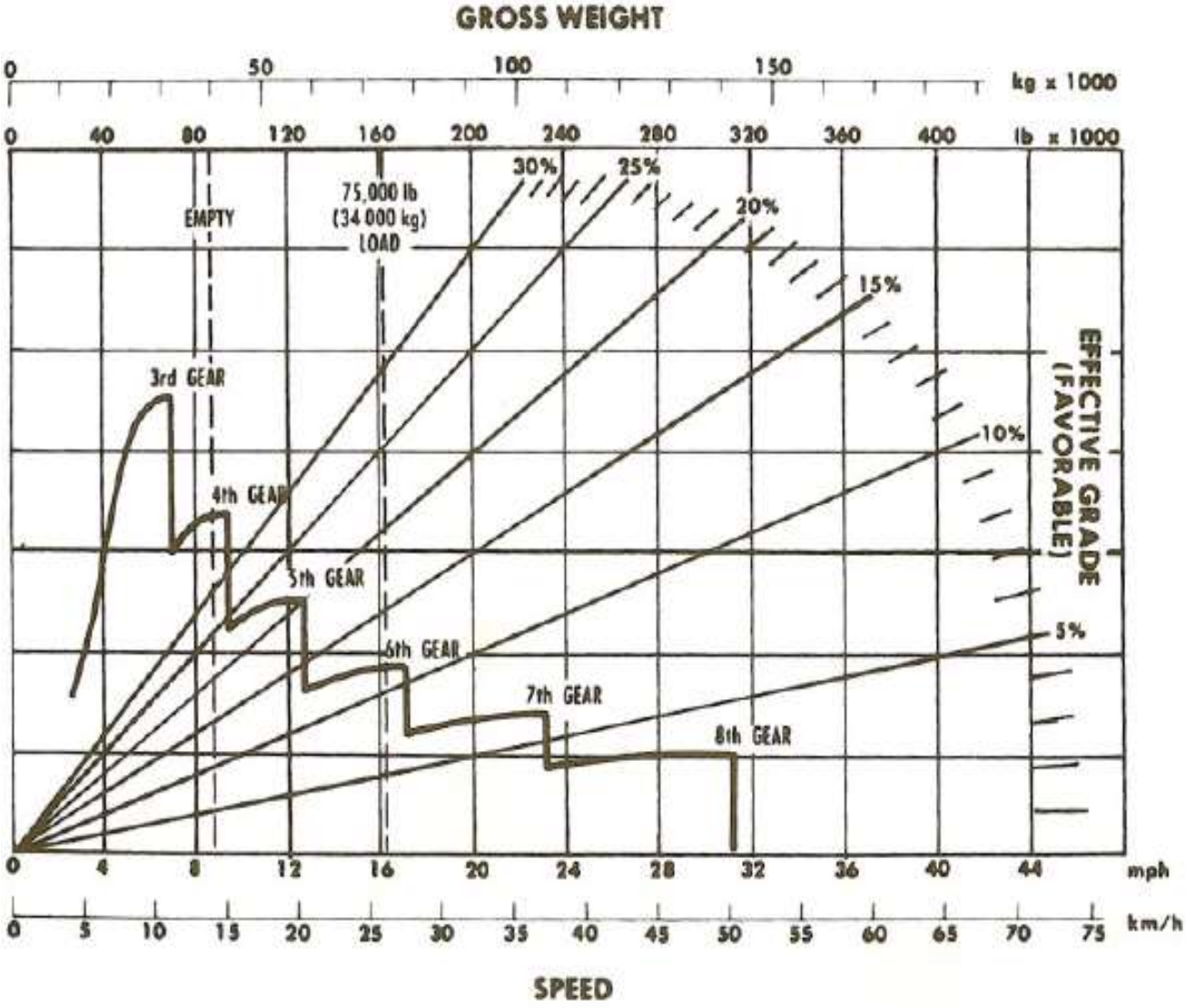

Estimating Travel Time

- The maximum speed that a vehicle can maintain over a section of the haul route cannot be used for calculating travel time over the section,
 - because it does not include vehicle acceleration and deceleration.

Estimating Travel Time

- One Method for accounting for acceleration and deceleration is:
 - to multiply the maximum vehicle speed by an average speed factor from Table 4-3 to obtain an average vehicle speed for the section.
 - Travel time for the section is then found by dividing the section length by the average vehicle speed.
 - When a section of the haul route involves both starting from rest and coming to a stop, the average speed factor from the first column of Table 4-3 should be **applied twice** (i.e., use the square of the table value) for that section.

Estimating Travel Time

- Second Method for estimating travel time over a section of haul route is :
 - to use the travel-time curves provided by some manufacturers.
 - Separate travel-time curves are prepared for loaded (rated payload) and empty conditions, as shown in Figures 4-4 and 4-5.
 - To **adjust for altitude deration** when using travel-time curves, multiply the time obtained from the curve by the quantity "1+ derating factor" to obtain the adjusted travel time.

Table 4-3: Average speed factors

Table 4-3 Average speed factors

Length of Haul Section		Starting from 0 or Coming to a Stop	Increasing Maximum Speed from Previous Section	Decreasing Maximum Speed from Previous Section
<i>ft</i>	<i>m</i>			
150	46	0.42	0.72	1.60
200	61	0.51	0.76	1.51
300	92	0.57	0.80	1.39
400	122	0.63	0.82	1.33
500	153	0.65	0.84	1.29
700	214	0.70	0.86	1.24
1000	305	0.74	0.89	1.19
2000	610	0.86	0.93	1.12
3000	915	0.90	0.95	1.08
4000	1220	0.93	0.96	1.05
5000	1525	0.95	0.97	1.04

631D (33.25 X 35) DISTANCE VS TIME – LOADED

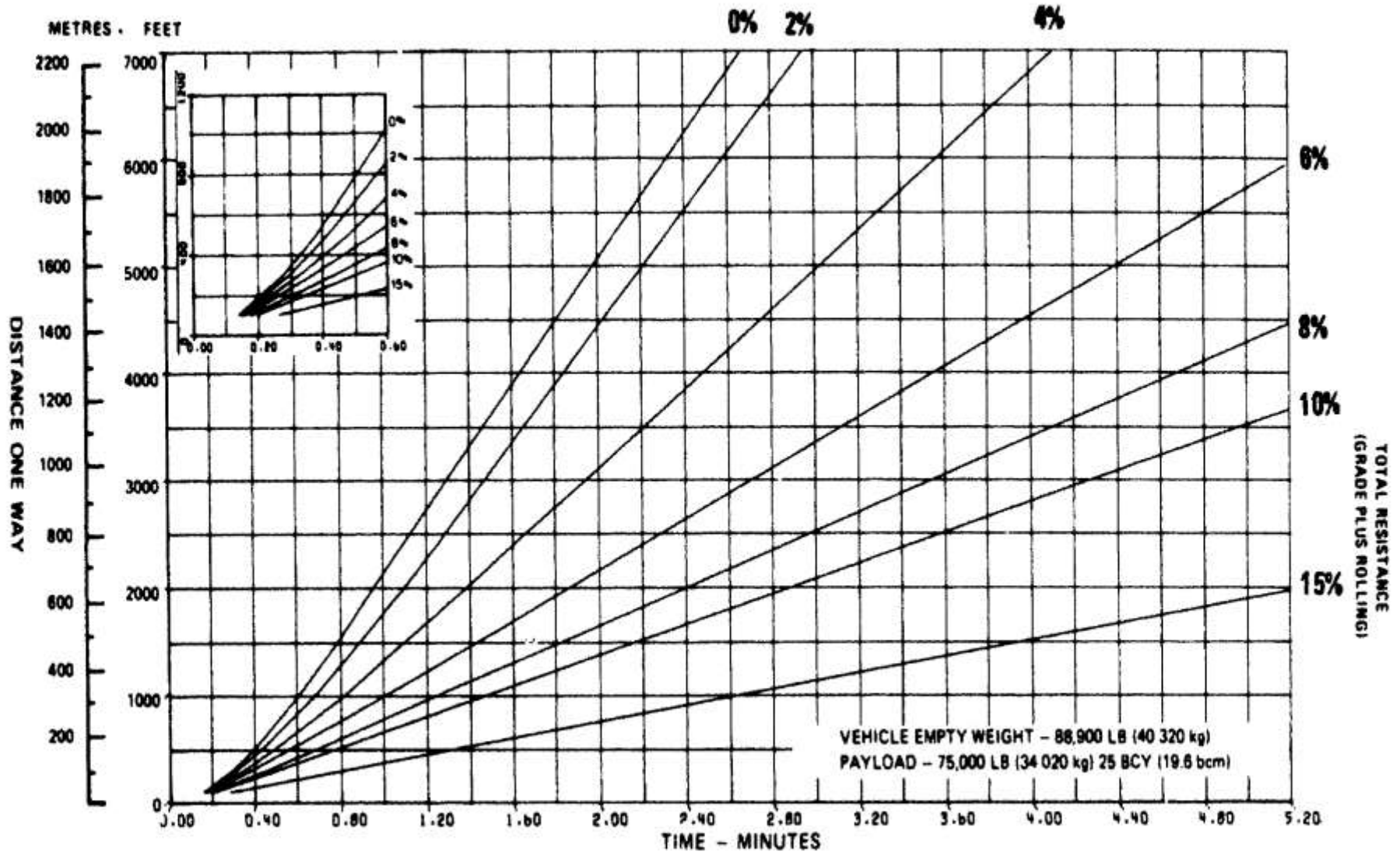

Figure 4-4 Scraper travel time—loaded. (Courtesy of Caterpillar Inc.)

631D (33.25 X 35) DISTANCE VS TIME – EMPTY

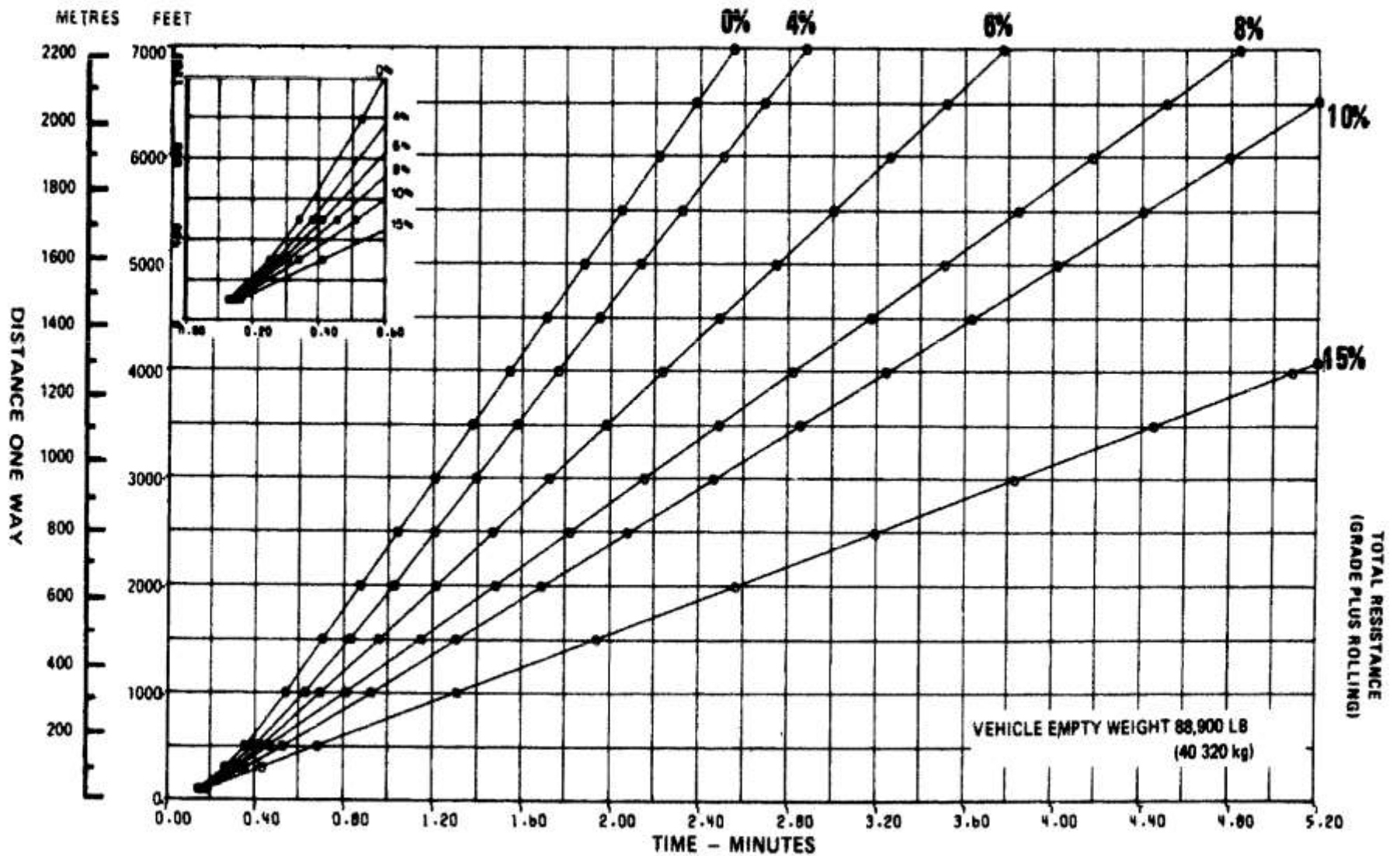
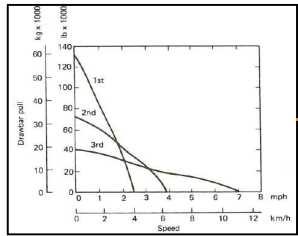

Figure 4-5 Scraper travel time—empty. (Courtesy of Caterpillar Inc.)

Travel Time ??



Performance Curve
Tractor

Travel speed
(Maximum)

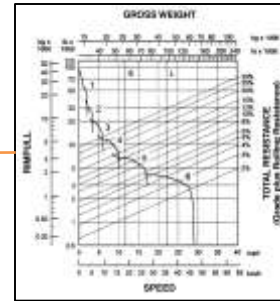

Performance Curve
Wheel

Travel speed
(Average)

Average
Speed
Factor

Travel Time

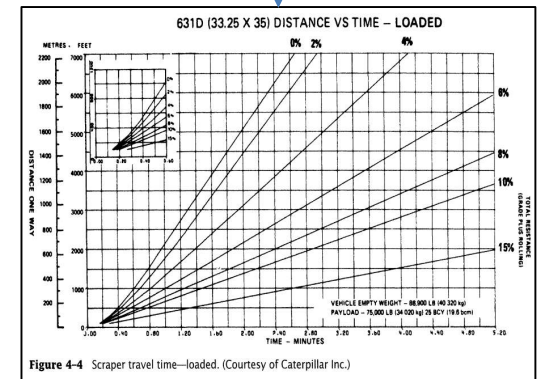

Figure 4-4 Scaper travel time—loaded. (Courtesy of Caterpillar Inc.)

Each **hauling segment** have its own **speed** depending on:

- *Loaded vs. Empty*
- *Effective grade (resistance)*

GENERAL HAUL DISTANCES FOR MOBILE SYSTEMS

