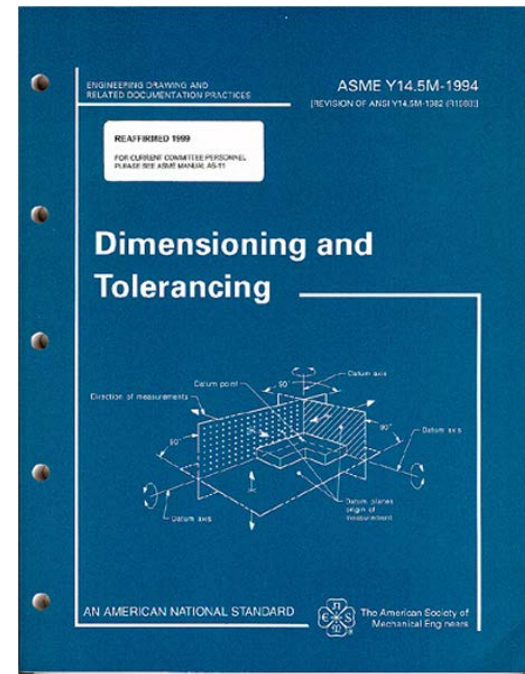

Content

- Overview
 - Form tolerances
 - Orientation tolerances
 - Location tolerances
 - Wrapping up
-

ANSI Y14.5-1994 Standard

This standard establishes uniform practices for defining and interpreting dimensions, and tolerances, and related requirements for use on engineering drawings.

The figures in this presentation are taken from Bruce Wilson's *Design Dimensioning and Tolerancing*.



Geometric Tolerancing

- What is Geometric tolerancing used for?

Geometric Tolerancing is used to specify the shape of features. Things like:

- Straightness
- Flatness
- Circularity
- Cylindricity
- Angularity
- Profiles
- Perpendicularity
- Parallelism
- Concentricity

And More...

Overview of Geometric Tolerances

Geometric tolerances define the shape of a feature as opposed to its size.

We will focus on three basic types of geometric tolerances:

1. **Form tolerances:** straightness, circularity, flatness, cylindricity;
 2. **Orientation tolerances;** perpendicularity, parallelism, angularity;
 3. **Location tolerances:** position, symmetry, concentricity.
-

Symbols for Geometric Tolerances

DIMENSIONING SYMBOLS		
CURRENT PRACTICE	ABBREVIATION IN NOTES	PARAMETER
∅	DIA	Diameter
S∅	SPHER DIA	Spherical Diameter
R	R	Radius
CR	CR	Controlled Radius
SR	SR	Spherical Radius
	CBORE	Counterbore
	SF or SFACE	Spotface
	CSK	Countersink
	DP	Deep
○	—	Dimension Origin
□	SQ	Square
()	REF	Reference
X	PL	Places, Times
)	—	Arc Length
	—	Slope
	—	Conical Taper
	—	Basic Dimension
	—	Statistical
	—	Between
	—	Datum Feature Triangle













DIMENSIONING SYMBOLS		
CURRENT PRACTICE	ABBREVIATION IN NOTES	PARAMETER
	—	Datum Feature Symbol
	—	Datum Target Symbol
	RFS	Regardless Of Feature Size
	MMC	Maximum Material Condition
	LMC	Least Material Condition
	—	Projected Tolerance Zone
	—	Straightness
	—	Flatness
	—	Circularity
	—	Cylindricity
	—	Perpendicularity
	—	Parallelism
	—	Angularity
	—	Position
	—	Symmetry
	—	Concentricity
	—	Circular Runout
	—	Total Runout
	—	Line Profile
	—	Surface Profile

Form

Orientation

Location

Most Common Symbols

	TYPE OF TOLERANCE	CHARACTERISTIC	SYMBOL	SEE:
FOR INDIVIDUAL FEATURES	FORM	STRAIGHTNESS	—	6.4.1
		FLATNESS		6.4.2
		CIRCULARITY (ROUNDNESS)		6.4.3
		CYLINDRICITY		6.4.4
FOR INDIVIDUAL OR RELATED FEATURES	PROFILE	PROFILE OF A LINE		6.5.2 (b)
		PROFILE OF A SURFACE		6.5.2 (a)
FOR RELATED FEATURES	ORIENTATION	ANGULARITY		6.6.2
		PERPENDICULARITY		6.6.4
		PARALLELISM		6.6.3
	LOCATION	POSITION		5.2
		CONCENTRICITY		5.11.3
		SYMMETRY		5.13
	RUNOUT	CIRCULAR RUNOUT		6.7.1.2.1
		TOTAL RUNOUT		6.7.1.2.2
• ARROWHEADS MAY BE FILLED OR NOT FILLED				3.3.1

Feature Control Frame

A geometric tolerance is prescribed using a feature control frame.

It has three components:

1. the tolerance symbol,
2. the tolerance value,
3. the datum labels for the reference frame.

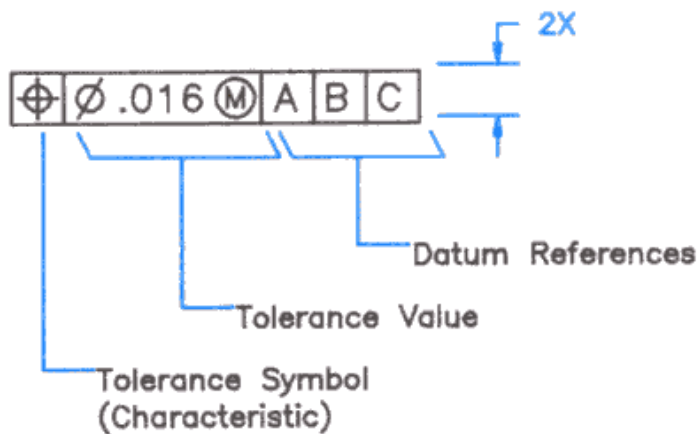

Figure 2-18. Feature control frames are always read from left to right.

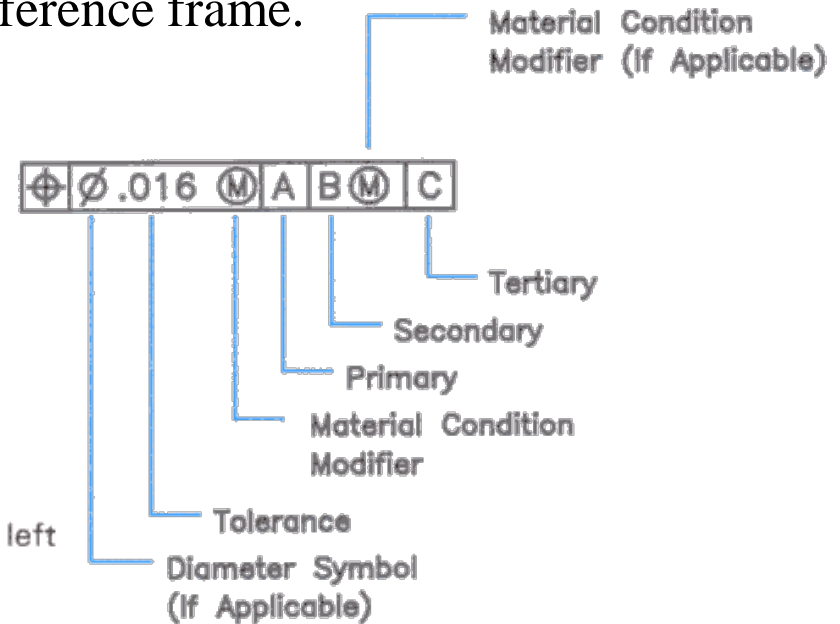
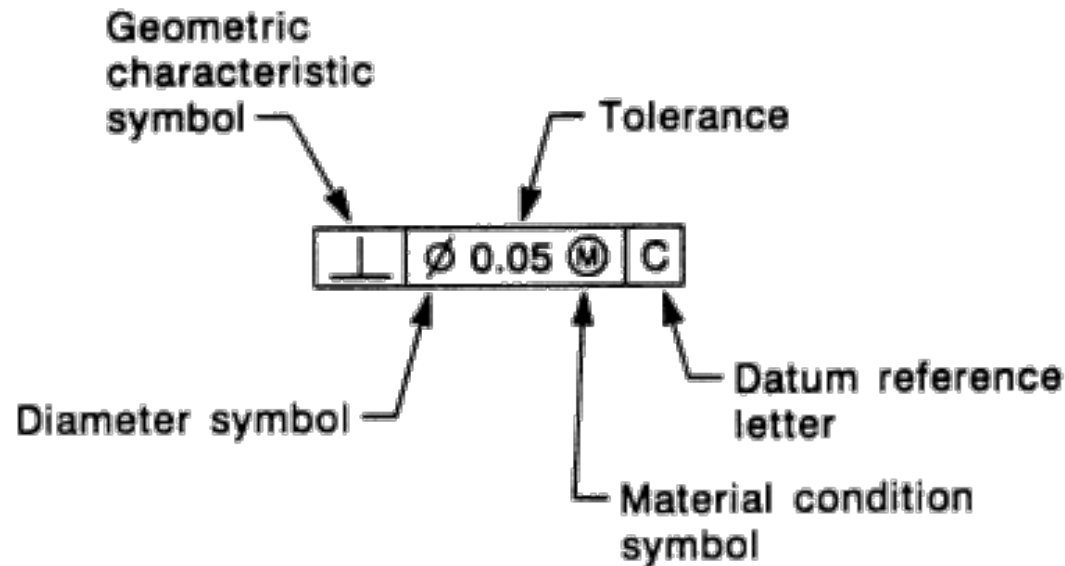

Figure 2-19. Whether a diameter symbol and material condition modifier are used, or omitted, depends on the desired tolerance specification and the type of feature being controlled.

Feature Control Frame

- How do you read this feature control frame?

“The specified feature must lie *perpendicular* within a tolerance zone of *0.05 diameter* at the *maximum material condition*, with respect to *datum axis C*.”



In other words, this places a limit on the amount of variation in perpendicularity between the feature axis and the datum axis. In a drawing, this feature control frame would accompany dimensional tolerances that control the feature size and position.

Reference Frame

A reference frame is defined by three perpendicular datum planes. The left-to-right sequence of datum planes defines their order of precedence.

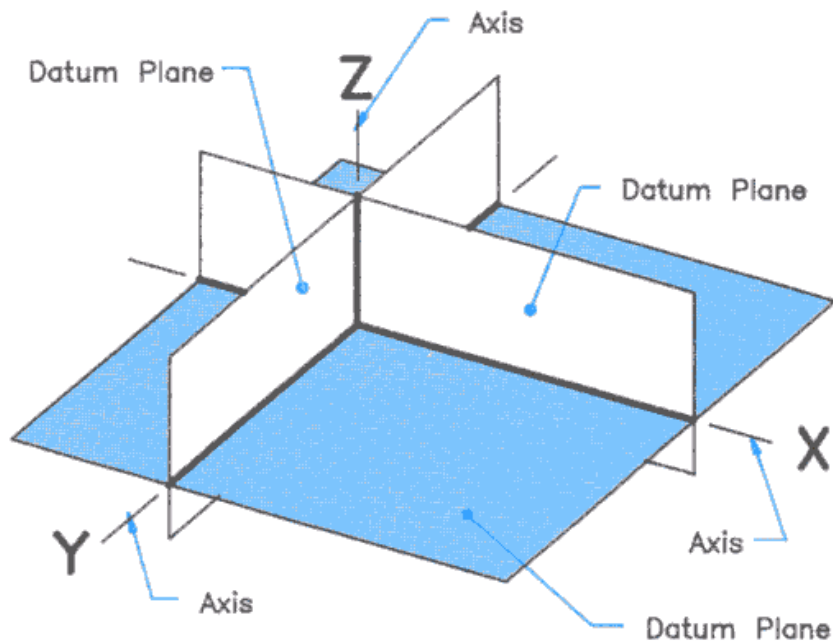

Figure 6-3. A datum reference frame is theoretically perfect and is made of three mutually perpendicular planes.

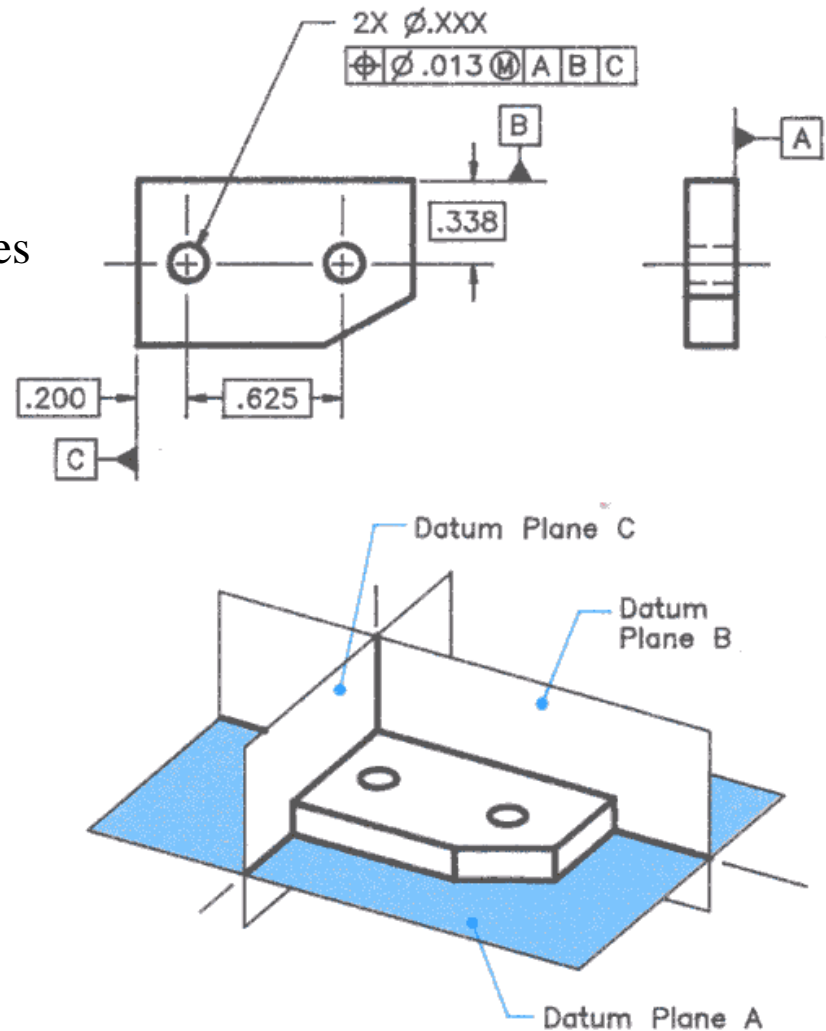

Figure 6-4. Datum references made in a feature control frame determine how a part is located in the datum reference frame.

Order of Precedence

The part is aligned with the datum planes of a reference frame using **3-2-1** contact alignment.

- **3** points of contact align the part to the primary datum plane;
- **2** points of contact align the part to the secondary datum plane;
- **1** point of contact aligns the part with the tertiary datum plane

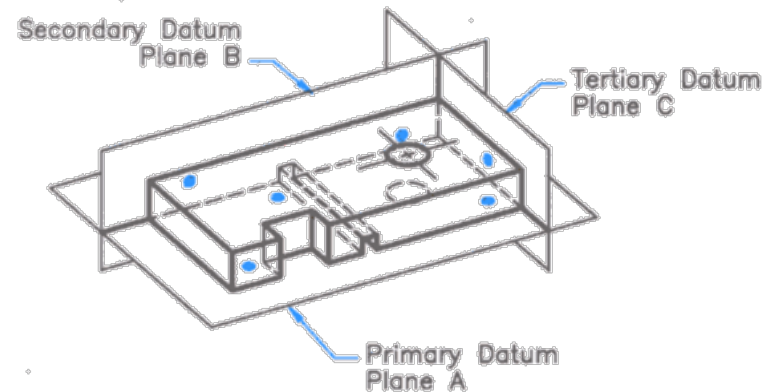
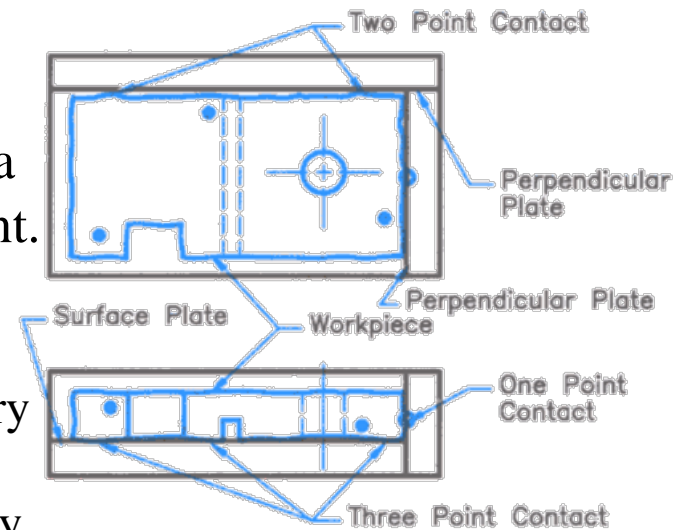
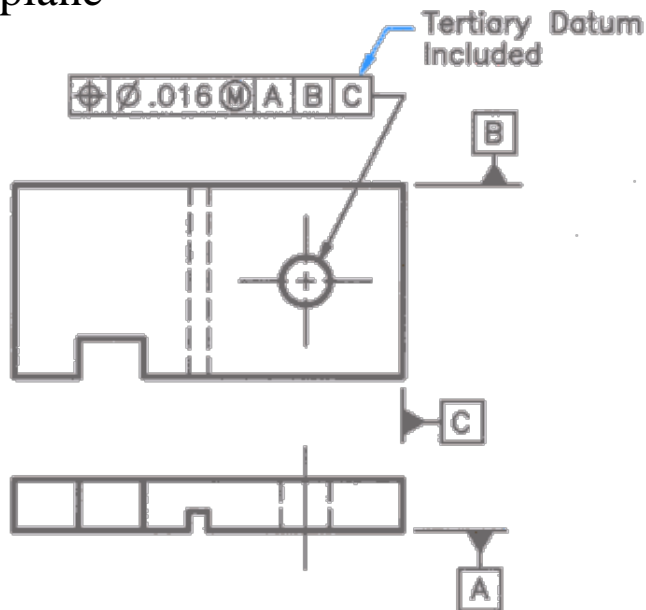

Figure 6-17. The tertiary datum plane is perpendicular to the primary and secondary planes, and is located by the tertiary datum feature on the part.

Using a Feature as a Datum

A feature such as a hole, shaft, or slot can be used as a datum.

In this case, the datum is the theoretical axis, centerline, or center plane of the feature.

The “circle M” denotes the datum is defined by the Maximum Material Condition (MMC) given by the tolerance.

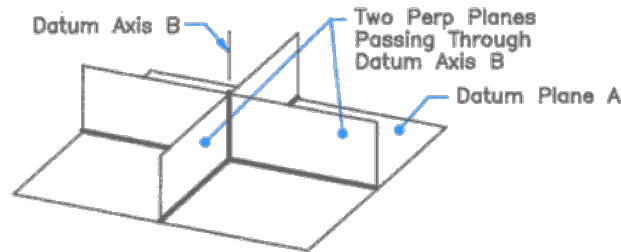
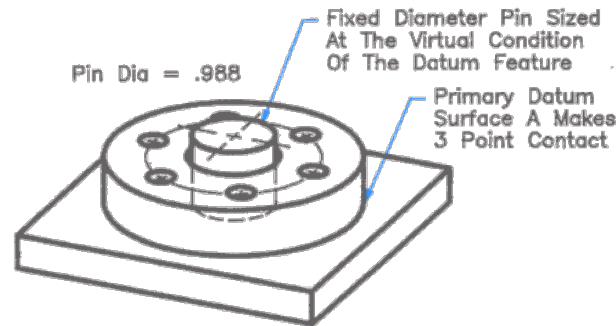
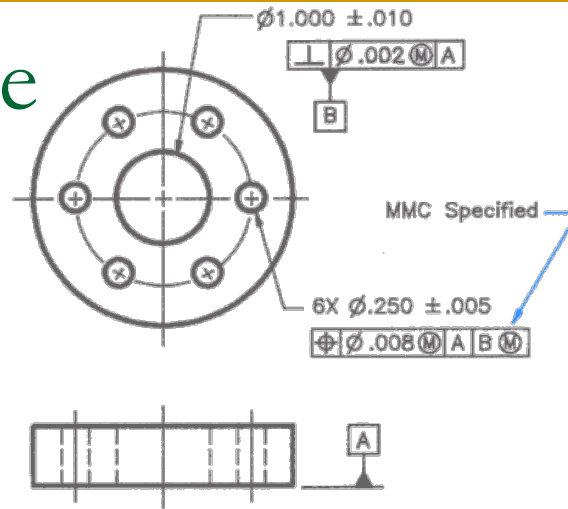

Figure 6-31. A secondary or tertiary datum reference showing an MMC modifier requires the datum to be simulated by a tool that has a size equal to the virtual condition of the datum feature.

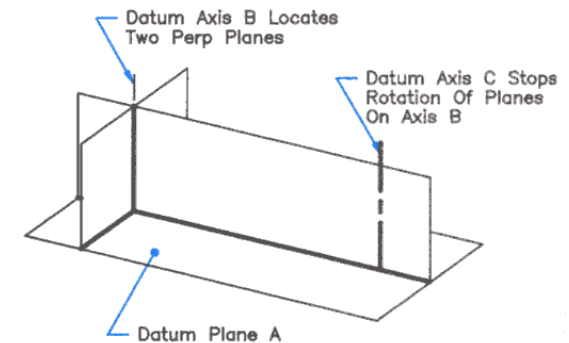
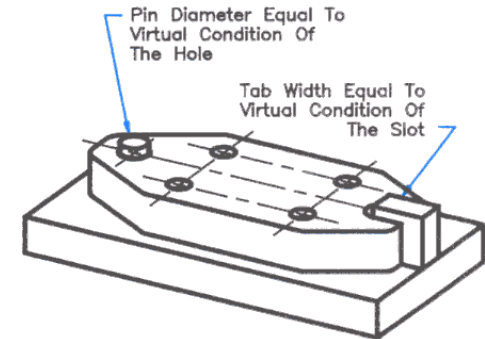
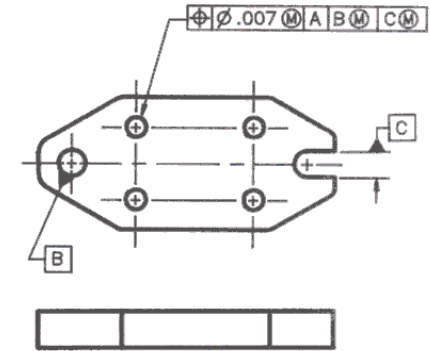

Figure 6-32. A primary datum surface and secondary datum feature of size can be used to establish the datum reference frame with a tertiary datum feature of size used to set the orientation of the datum reference frame.

Material Conditions

- **Maximum Material Condition (MMC):** The condition in which a feature contains the maximum amount of material within the stated limits. *e.g.* minimum hole diameter, maximum shaft diameter.
 - **Least Material Condition (LMC):** The condition in which a feature contains the least amount of material within the stated limits. *e.g.* maximum hole diameter, minimum shaft diameter
 - **Regardless of Feature Size (RFS):** This is the default condition for all geometric tolerances. No bonus tolerances are allowed and functional gauges may not be used.
-

Material Conditions

ANSI Y14.5M RULE #1:

A dimensioned feature must have perfect form at its maximum material condition.

This means:

- A **hole** is a perfect cylinder when it is at its **smallest** permissible diameter,
- A **shaft** is a perfect cylinder when at its **largest** diameter.
- Planes are perfectly parallel when at their maximum distance.

ANSI Y14.5M RULE #2:

If no material condition is specified, then it is “regardless of feature size.”

Material Conditions

- Which one is which?

MMC vs. LMC

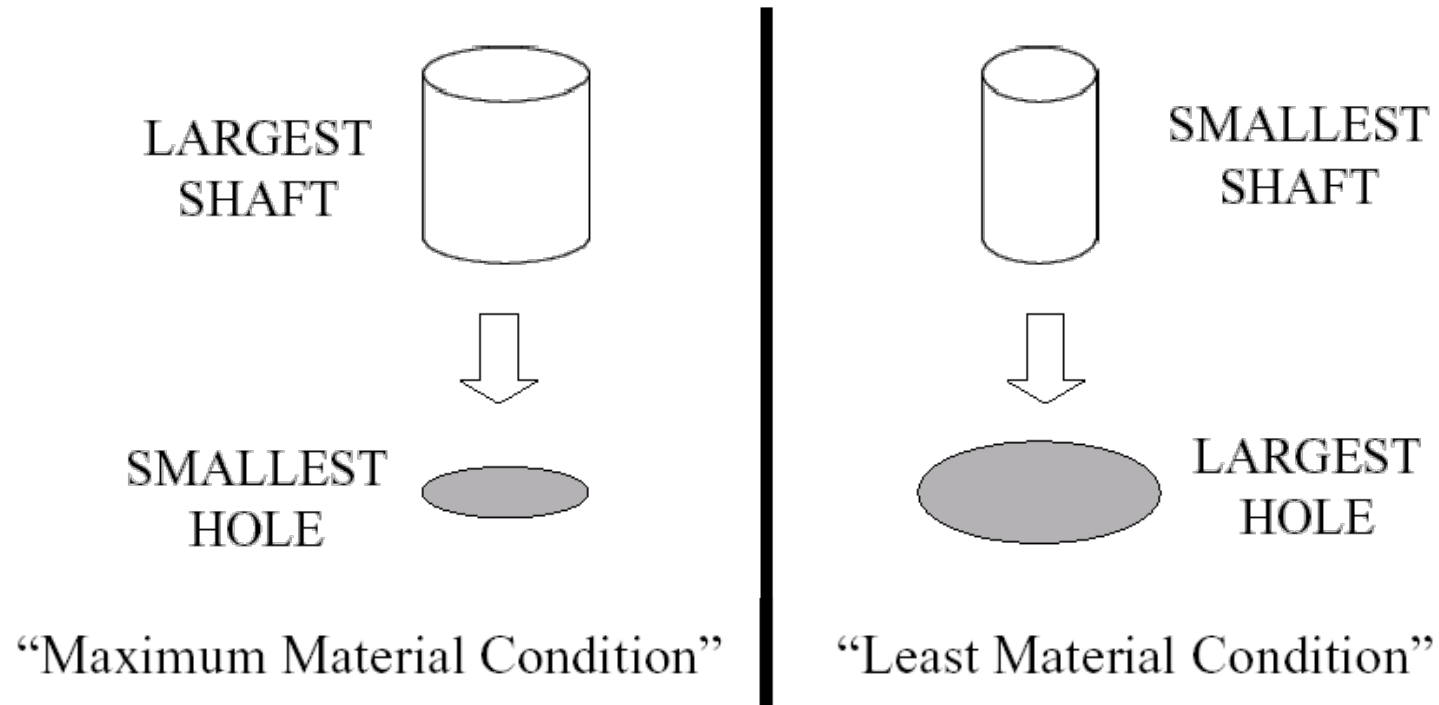

Straightness of a Shaft

- A shaft has a size tolerance defined for its fit into a hole. A shaft meets this tolerance if at every point along its length a diameter measurement falls within the specified values.
- This allows the shaft to be bent into any shape. A straightness tolerance on the shaft axis specifies the amount of bend allowed.

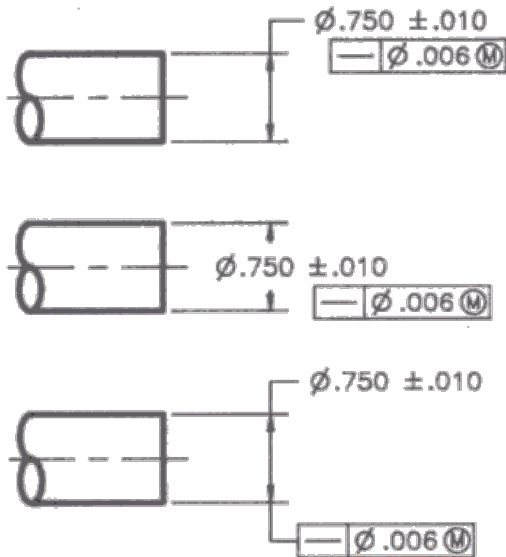

Figure 5-16. The axis of a feature can be controlled by placing a form tolerance adjacent to the size dimension or on the dimension line.

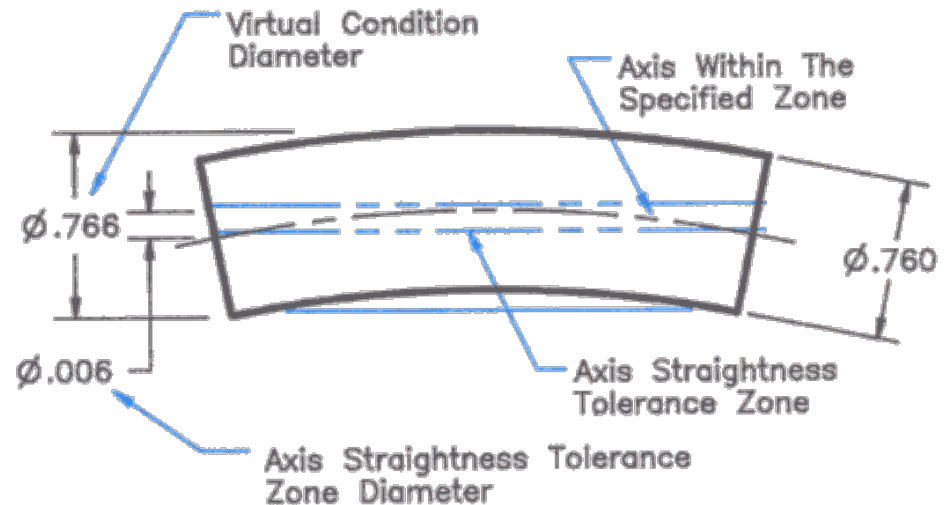

Figure 5-17. A straightness tolerance applied to control axis straightness permits the part to have an axis straightness error when the part is at MMC.

Straightness of a Shaft

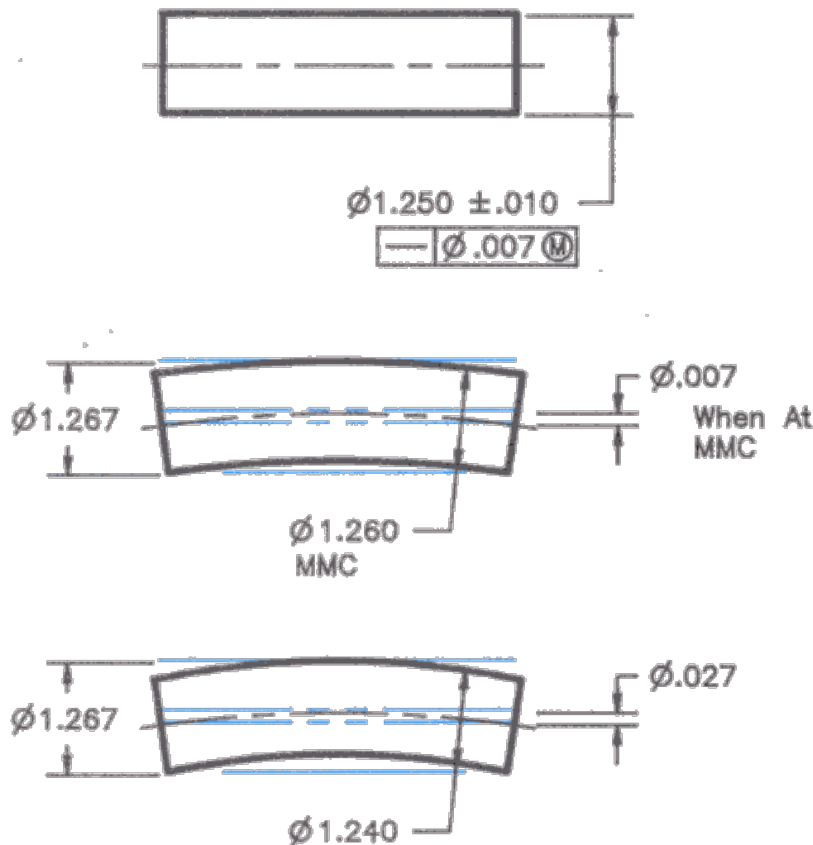

Figure 5-18. The permitted axis error applied to a cylinder has an effect on the apparent diameter of the cylinder. The combined effect of the MMC size and the permitted axis error is known as the virtual condition.

MMC Of Shaft
+ Tolerance

Virtual Condition

$$\frac{1.260 \text{ MMC} + .007 \text{ Tol}}{1.267 \text{ Vc}}$$

Produced Diameter	Allowable Tolerance
1.260	.007
1.259	.008
1.258	.009
1.242	.025
1.241	.026
1.240	.027

- Add the straightness tolerance to the maximum shaft size (MMC) to obtain a “**virtual condition**” **Vc**, or virtual hole, that the shaft must fit to be acceptable.

Straightness of a Hole

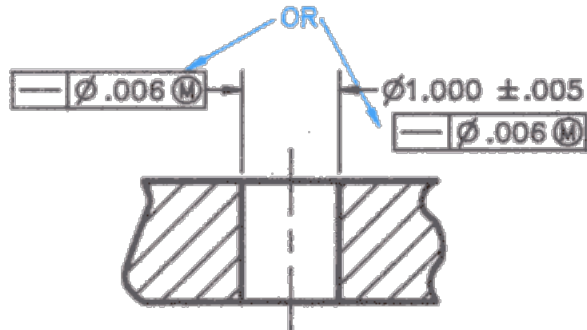

Figure 5-19. Form tolerance can be applied to internal features such as holes.

- The size tolerance for a hole defines the range of sizes of its diameter at each point along the centerline. This does not eliminate a curve to the hole.
- The straightness tolerance specifies the allowable curve to the hole.
- Subtract the straightness tolerance from the smallest hole size (MMC) to define the virtual condition Vc, or virtual shaft, that must fit the hole for it to be acceptable.

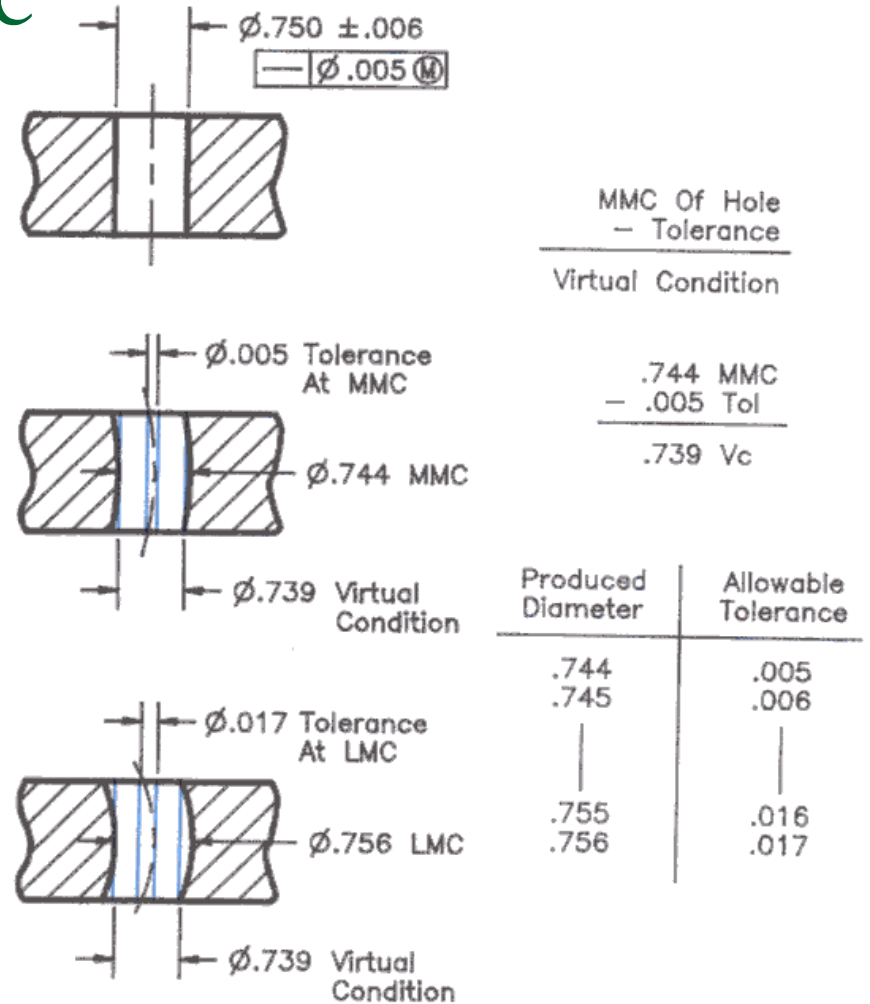

Figure 5-20. The virtual condition of a hole has a diameter smaller than the MMC diameter permitted by the size dimension.

Straightness of a Center Plane

- The size dimension of a rectangular part defines the range of sizes at any cross-section.
- The straightness tolerance specifies the allowable curve to the entire side.
- Add the straightness tolerance to the maximum size (MMC) to define a virtual condition V_c that the part must fit into in order to meet the tolerance.

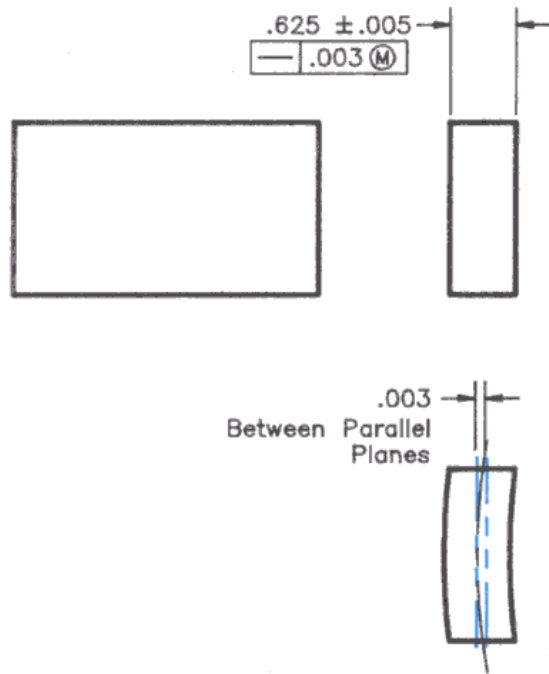

Figure 5-28. Center plane flatness is tolerated by placing the feature control frame, showing a straightness tolerance, adjacent to the dimension value.

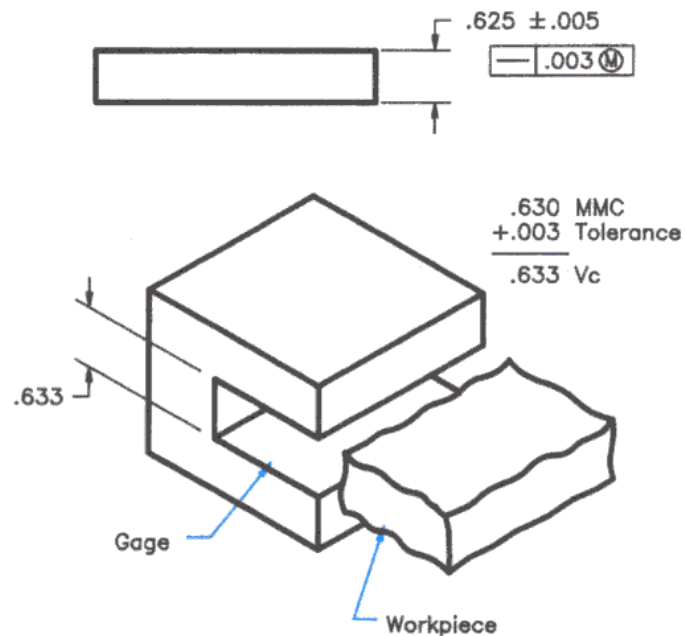

Figure 5-29. Flatness applied to control the center plane at MMC can be verified with a functional gage.

Flatness, Circularity and Cylindricity

The **flatness** tolerance defines a distance between parallel planes that must contain the highest and lowest points on a face.

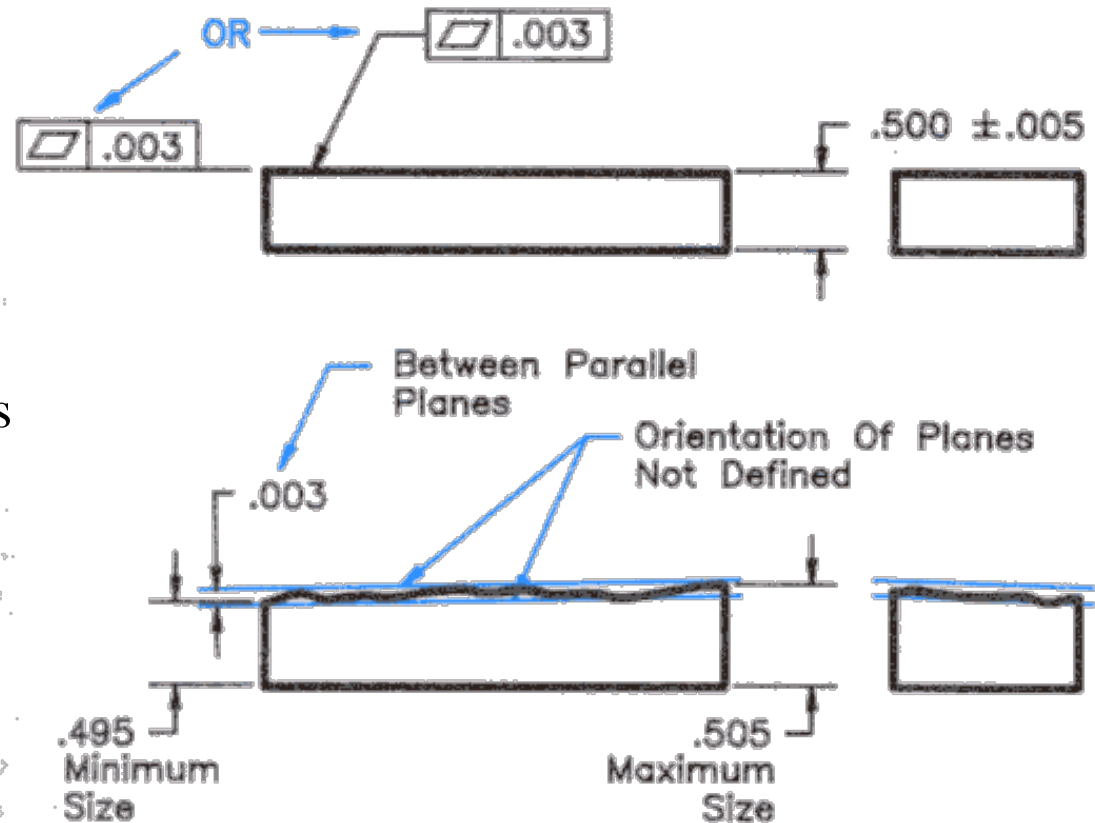

Figure 5-25. Flatness tolerances create a tolerance zone bounded by two parallel planes.

Flatness, Circularity and Cylindricity

The **circularity** tolerance defines a pair of concentric circles that must contain the maximum and minimum radius points of a circle.

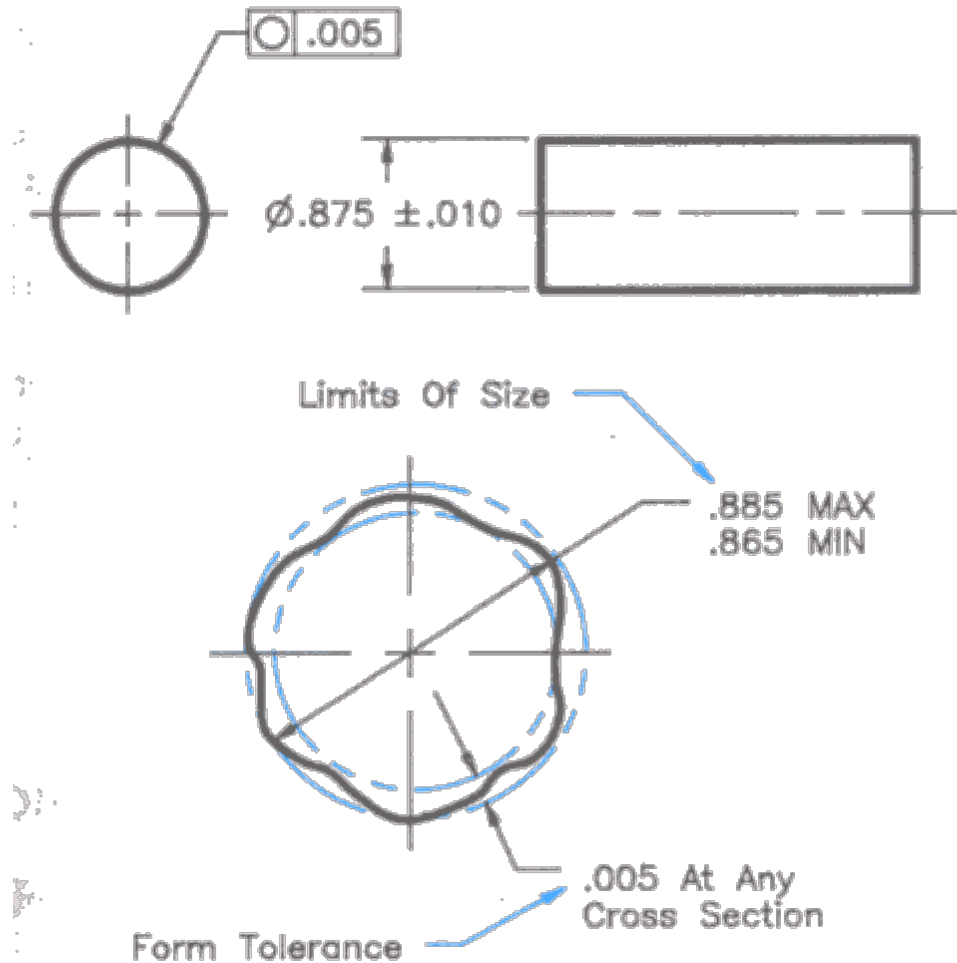

Figure 5-30. Circularity tolerances control circular cross sections.

Flatness, Circularity and Cylindricity

The **cylindricity** tolerance defines a pair of concentric cylinders that must contain the maximum and minimum radius points along a cylinder.

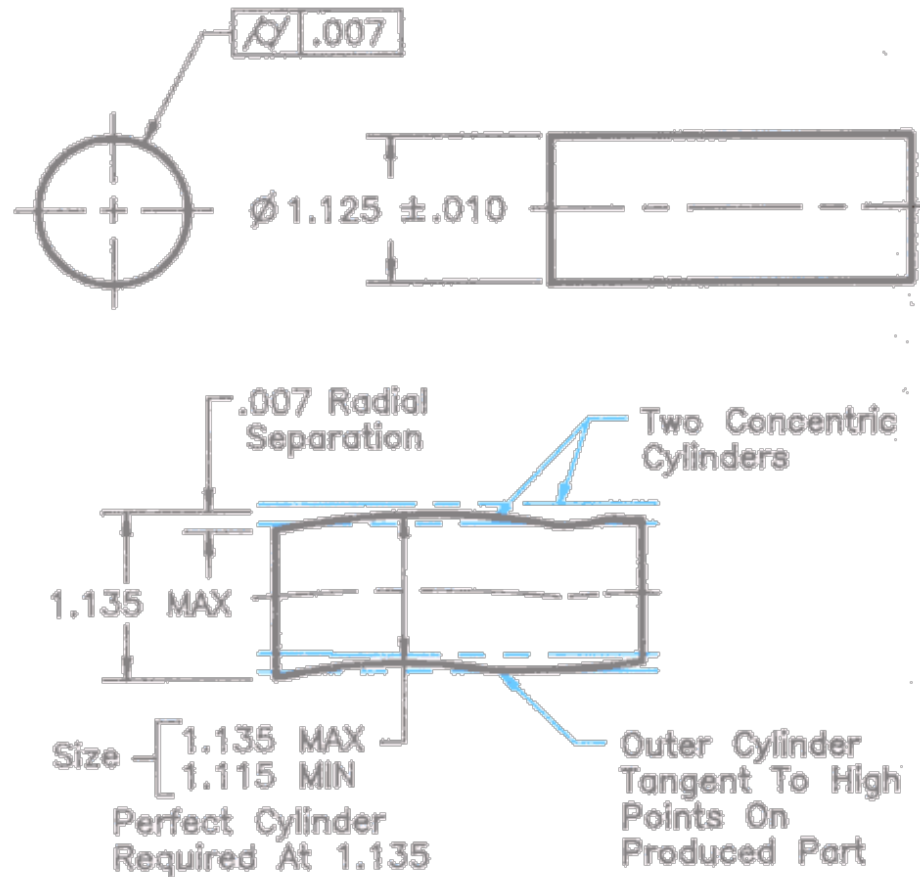

Figure 5-31. Cylindricity tolerances result in a tolerance zone bounded by two concentric cylinders.

Parallelism Tolerance

A parallelism tolerance is measured relative to a datum specified in the control frame.

If there is no material condition (i.e., regardless of feature size), then the tolerance defines parallel planes that must contain the maximum and minimum points on the face.

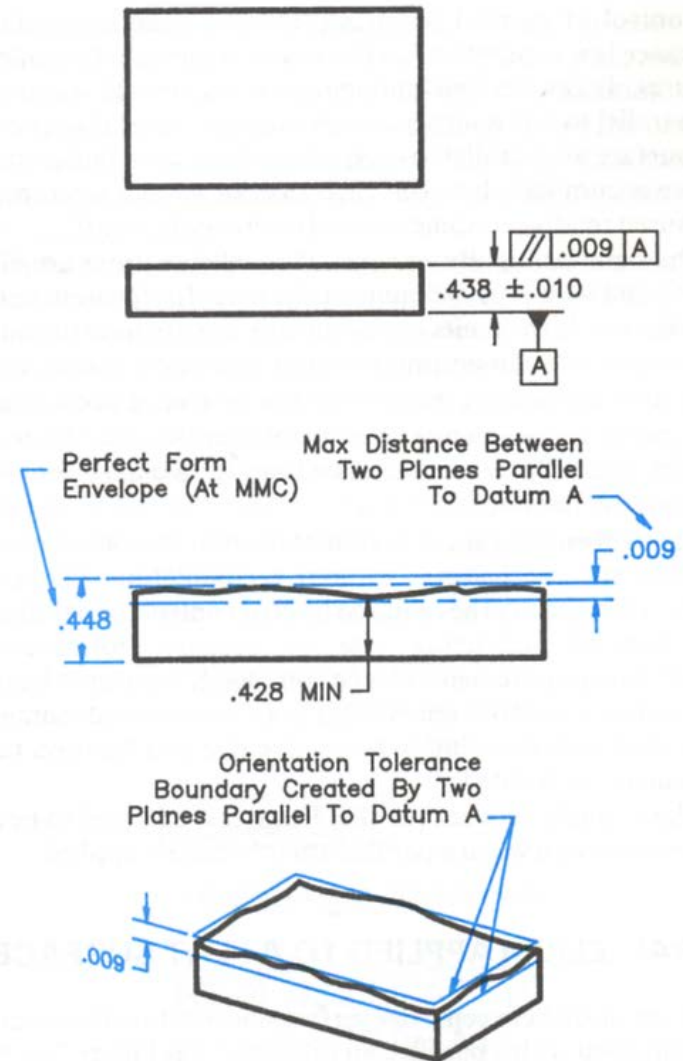

Figure 7-6. Two planes form the boundary for a parallelism tolerance.

Parallelism Tolerance

If MMC is specified for the tolerance value:

- If it is an external feature, then the tolerance is added to the maximum dimension to define a virtual condition that the part must fit;
- If it is an internal feature, then the tolerance is subtracted to define the maximum dimension that must fit into the part.

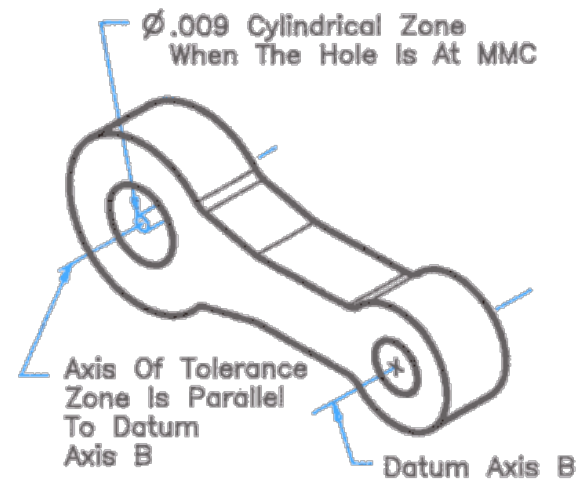
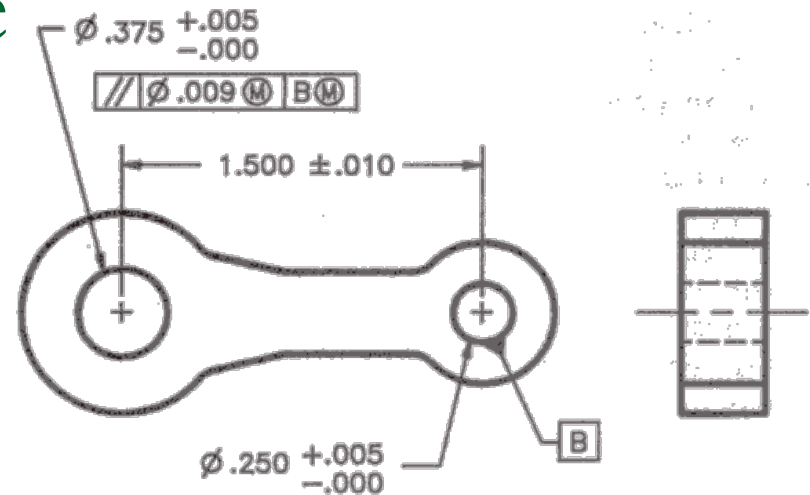

Figure 7-8. Parallelism can be used to control the orientation of one axis to another.

Perpendicularity

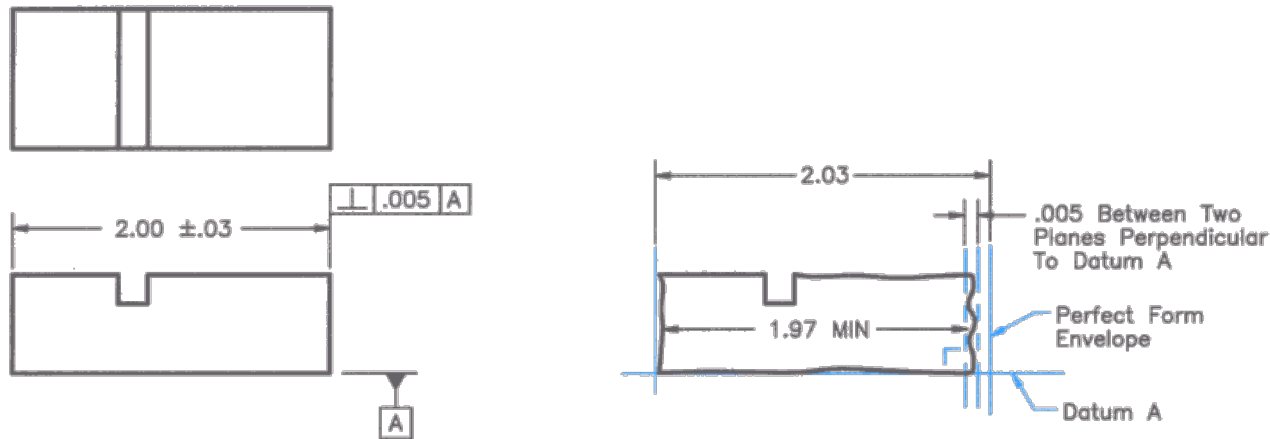

Figure 7-12. The tolerance zone for a perpendicularity tolerance on a flat surface is bounded by two planes.

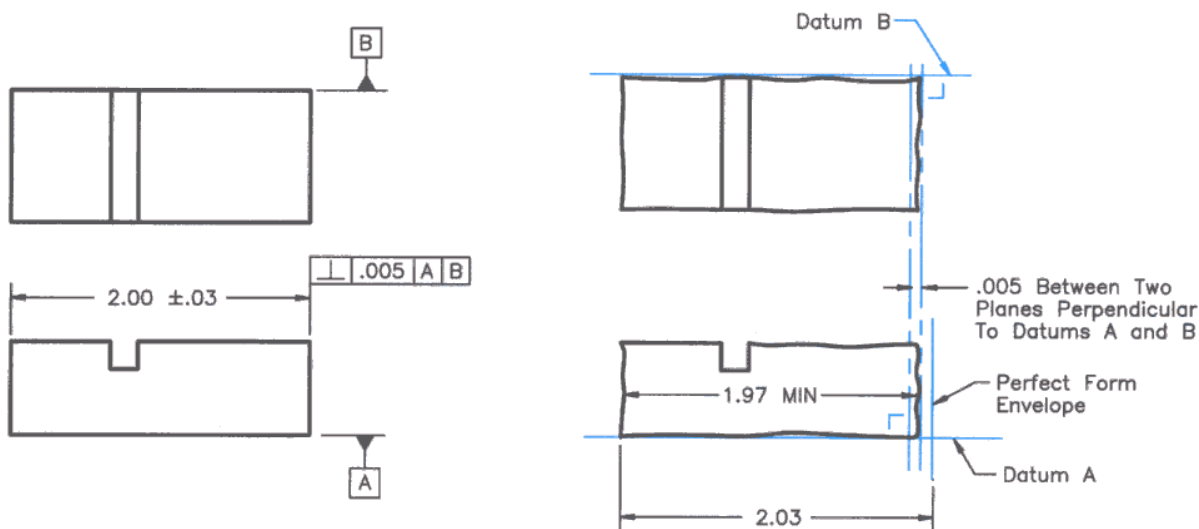

Figure 7-14. A perpendicularity tolerance can be referenced to two datums.

A perpendicular tolerance is measured relative to a datum plane.

It defines two planes that must contain all the points of the face.

A second datum can be used to locate where the measurements are taken.

Perpendicular Shaft, Hole, and Center Plane

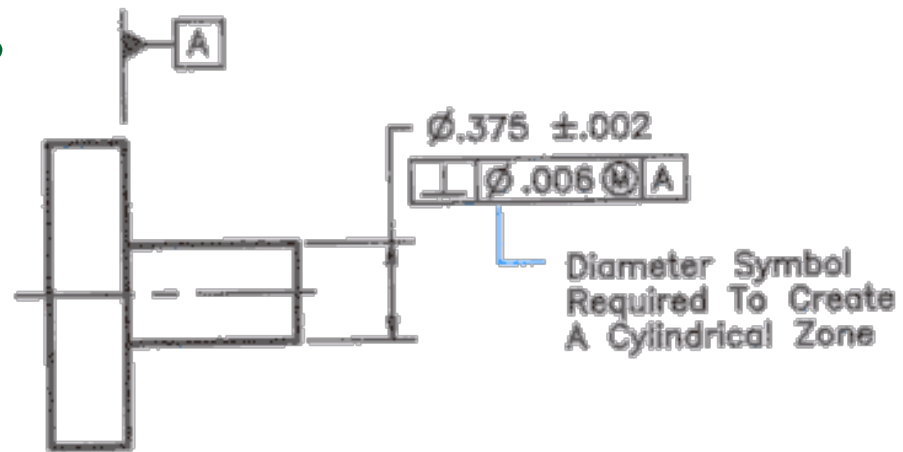

- **Shaft:** The maximum shaft size plus the tolerance defines the virtual hole.

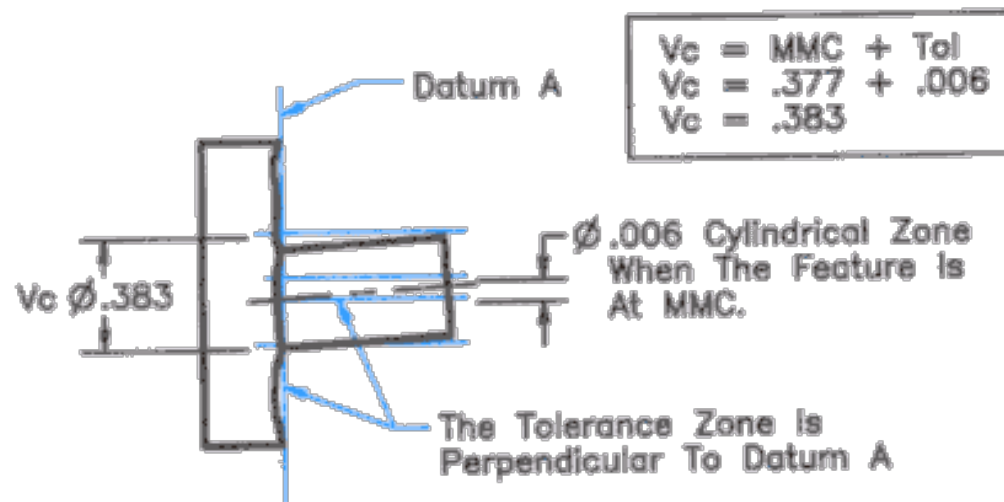

Figure 7-19. The virtual condition for an external feature of size is larger than the MMC of the feature.

Perpendicular Shaft, Hole, and Center Plane

Hole: The minimum hole size minus the tolerance defines the virtual shaft.

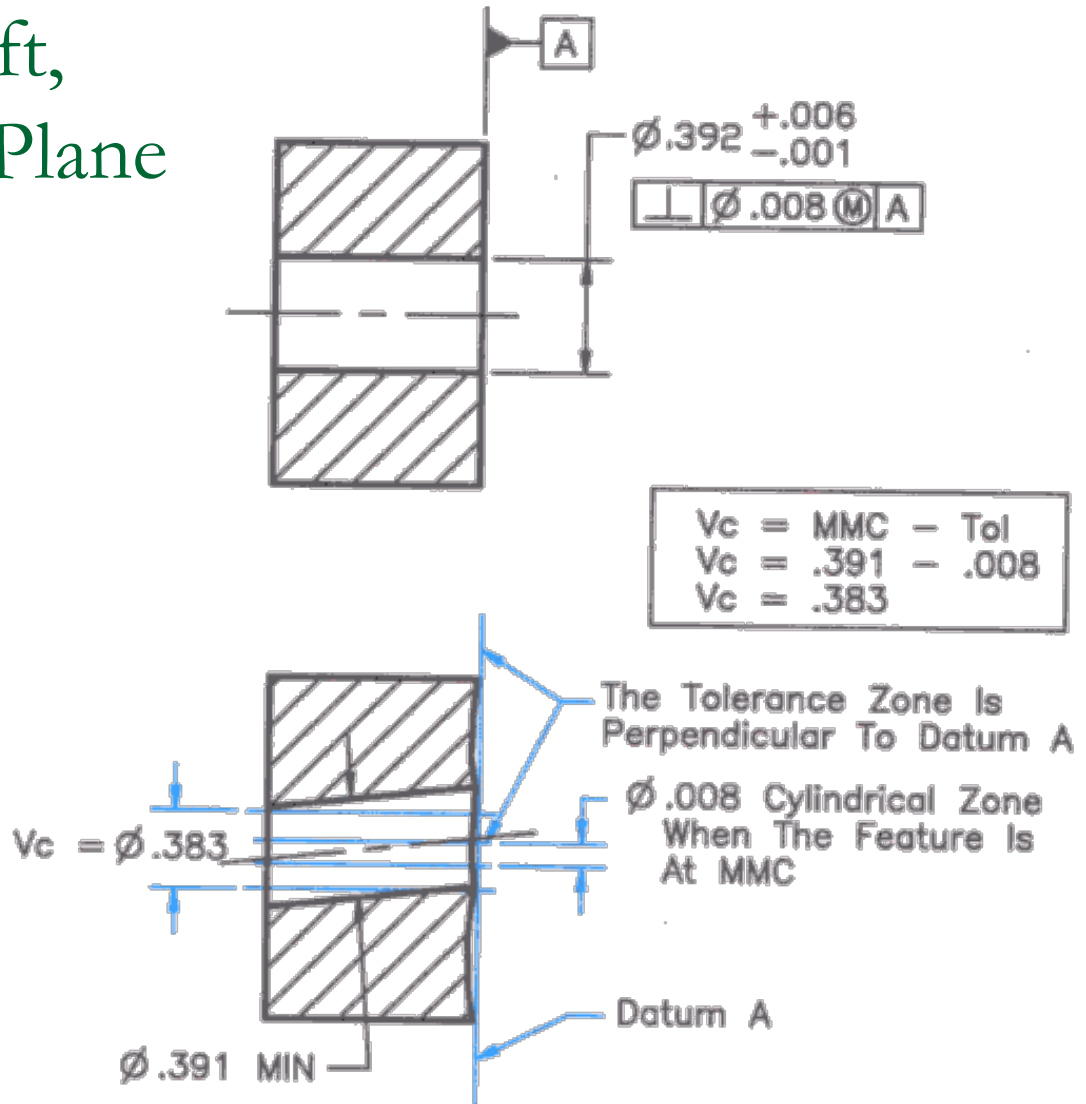

Figure 7-21. The virtual condition for an internal feature of size is smaller than the MMC of the feature.

Perpendicular Shaft, Hole, and Center Plane

Plane: The tolerance defines the variation of the location of the center plane.

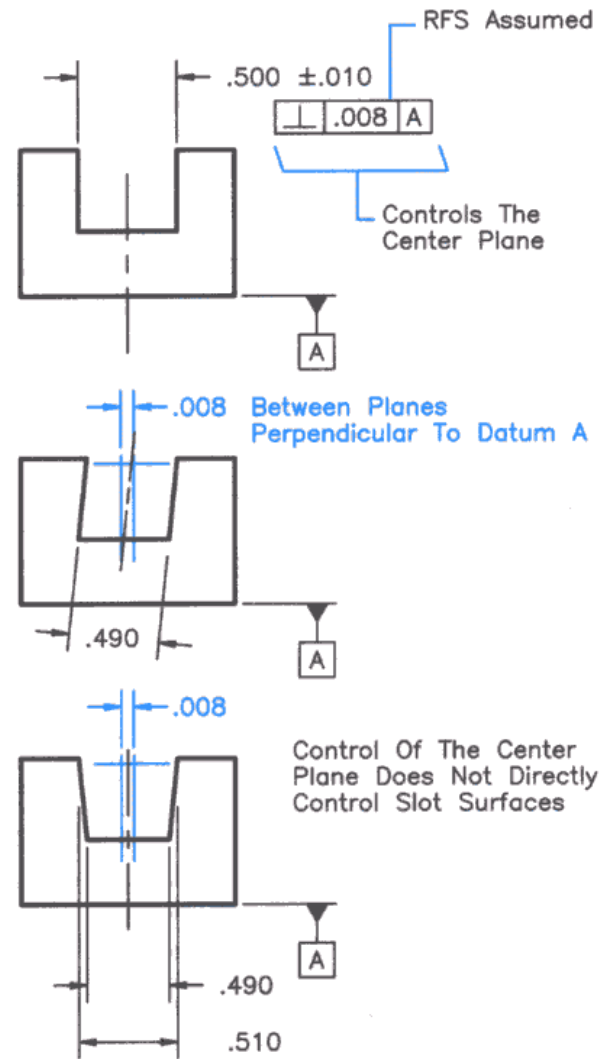

Figure 7-24. An orientation tolerance applied to a rectangular feature of size controls the orientation of the center plane of the feature.

Angularity

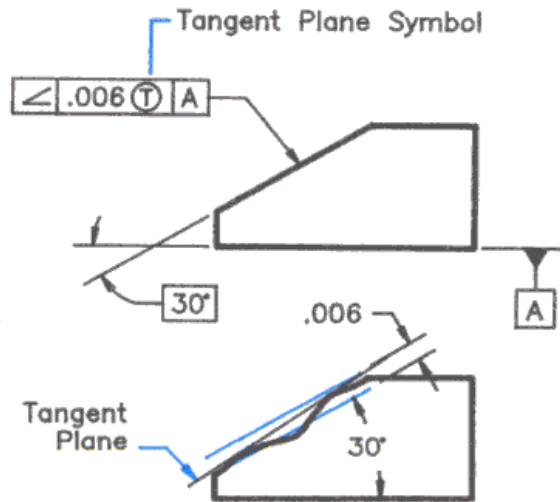

Figure 7-30. Angularity may be specified to control the plane that is tangent to surface high points.

An angularity tolerance is measured relative to a datum plane.

It defines a pair of planes that must

1. contain all the points on the angled face of the part, or
2. if specified, the plane tangent to the high points of the face.

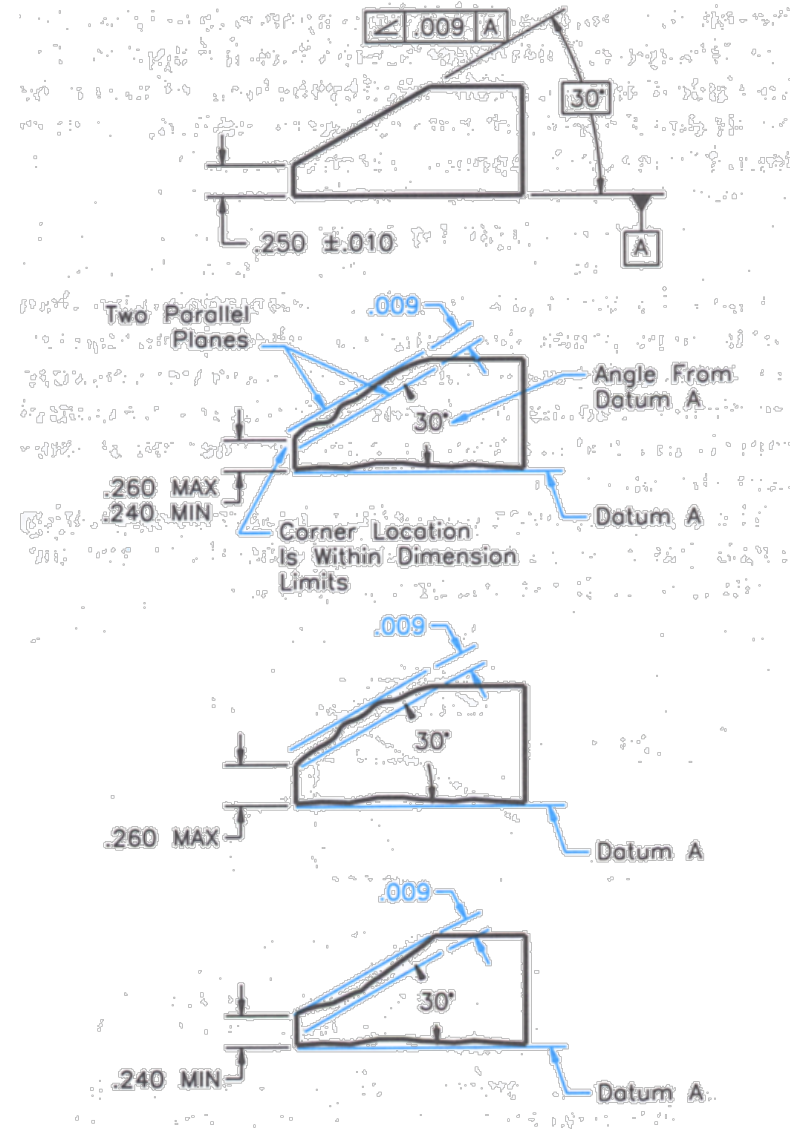

Figure 7-27. The angle dimension defining the surface orientation must be basic when an angularity tolerance is applied.

Position Tolerance for a Hole

- The position tolerance for a hole defines a zone that has a defined shape, size, location and orientation.
- It has the diameter specified by the tolerance and extends the length of the hole.
- Basic dimensions locate the theoretically exact center of the hole and the center of the tolerance zone.
- Basic dimensions are measured from the datum reference frame.

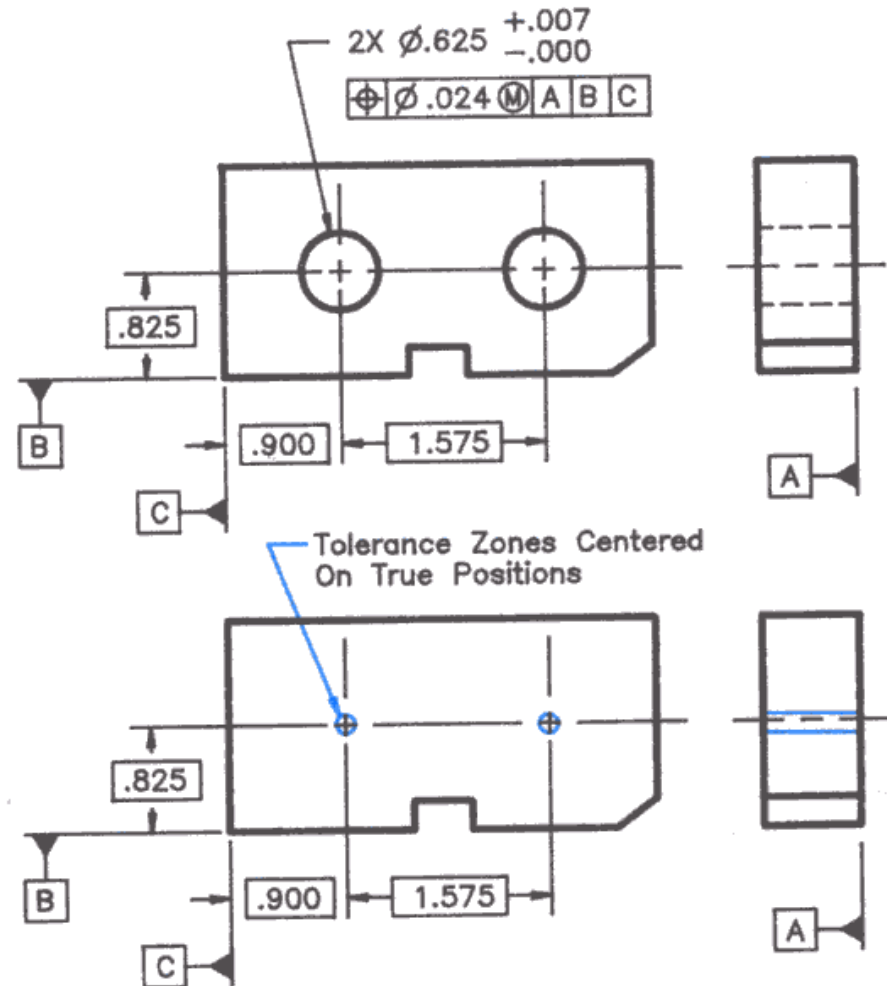

Figure 8-6. Tolerance zones for holes are centered on the theoretically true positions for the holes.

Material Condition Modifiers

MMC:

If the tolerance zone is prescribed for the maximum material condition (smallest hole), then the zone expands by the same amount that the hole is larger in size.

Use MMC for holes used in clearance fits.

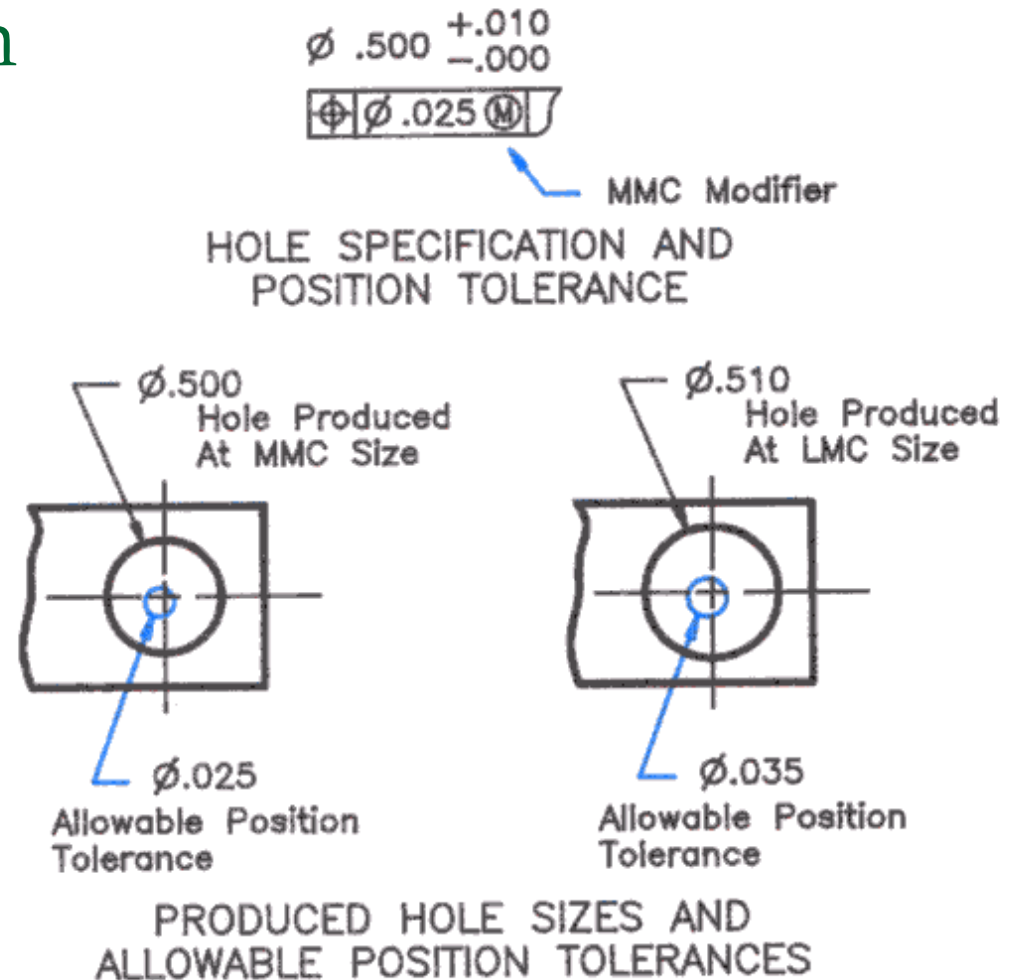

Figure 8-9. The position tolerance zone increases in size when the produced feature size departs from MMC and the MMC modifier is applied to the tolerance specification.

Material Condition Modifiers

RFS:

No material condition modifier means the tolerance is “regardless of feature size.”

Use RFS for holes used in interference or press fits.



HOLE SPECIFICATION AND POSITION TOLERANCE

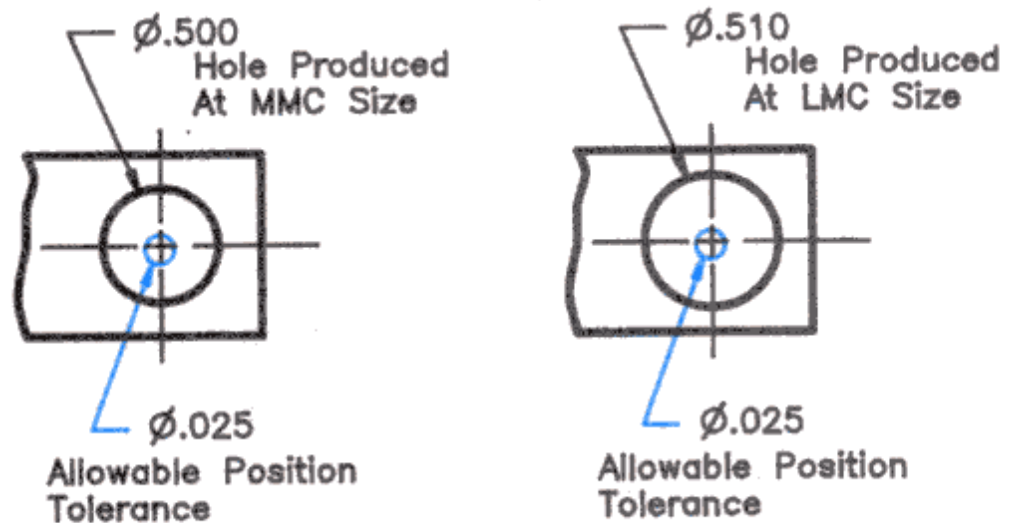

PRODUCED HOLE SIZES AND ALLOWABLE POSITION TOLERANCES

Figure 8-8. The position tolerance zone is not affected by the produced feature size when the RFS modifier is applicable to the tolerance specification.

Datum Reference in a Composite Tolerance

A datum specification for the pattern only specifies the orientation of the pattern tolerance zones.

Primary datum specified.

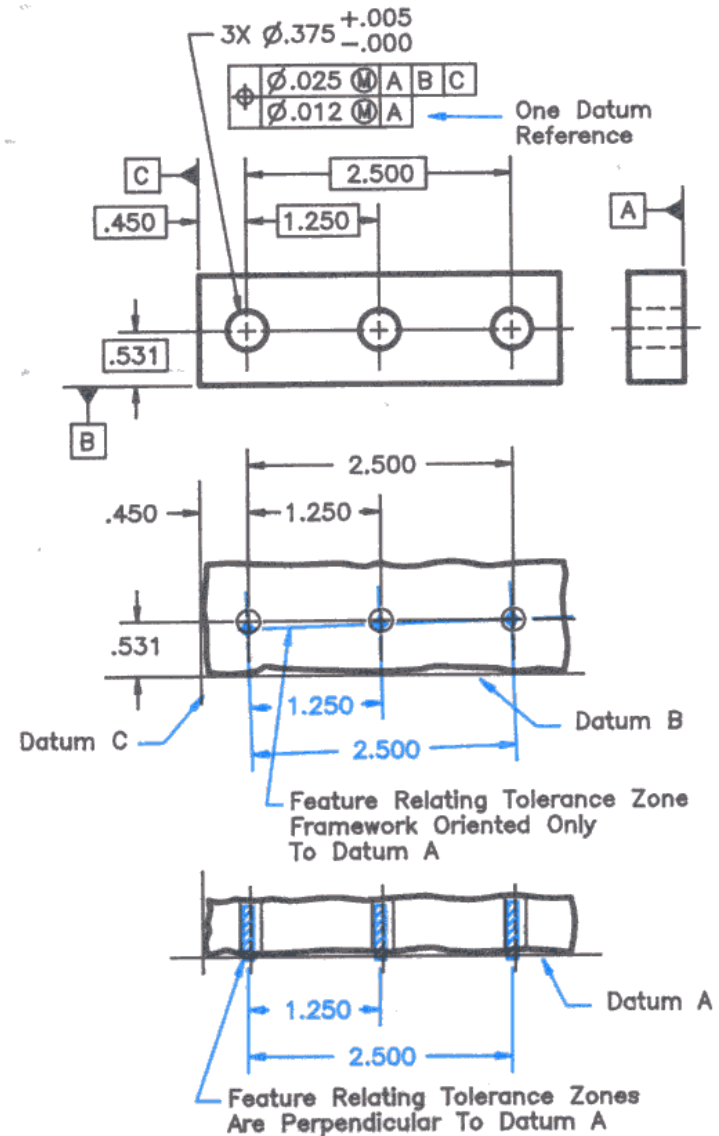

Figure 9-6. The primary datum reference requires the feature relating tolerance zones to be properly oriented to the primary datum.

Datum Reference in a Composite Tolerance

No datum for the pattern

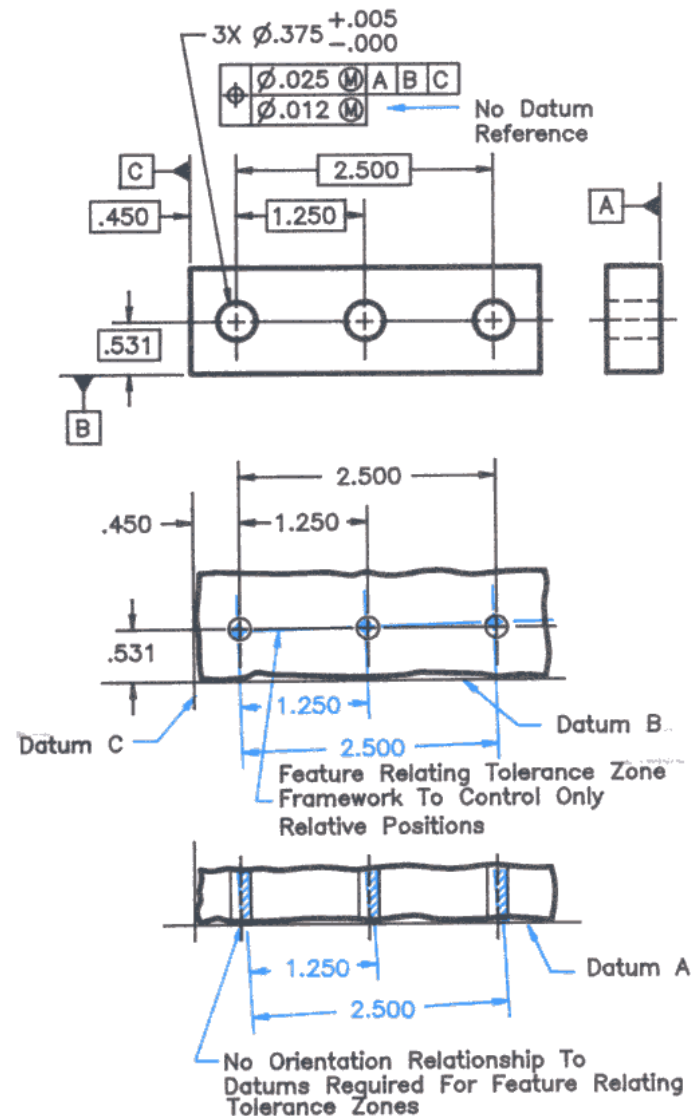

Figure 9-5. Omitting all datum references from the second line releases all orientation requirements from the feature relating tolerance. The second line of the composite tolerance only controls feature-to-feature locations.

Summary

- Geometric tolerances are different from the tolerances allowed for the size of feature, they specify the allowable variation of the shape of a feature.
 - There are three basic types of geometric tolerances: Form, Orientation and Position tolerances.
 - Geometric tolerances are specified using a control frame consisting of a tolerance symbol, a tolerance value and optional datum planes.
 - Material condition modifiers define the condition at which the tolerance is to be applied. If the maximum material condition is specified, then there is a “bonus tolerance” associated with a decrease in material.
1. The form of a feature is assumed to be perfect at its maximum material condition.
 2. If no material condition is specified, then it is regard less of feature size.
-

Additional materials

- http://www.engineersedge.com/tolerance_calc_menu.shtml
 - <http://www.engineersedge.com/gdt.htm>
-