

King Saud University

College of Engineering

IE – 462: “Industrial Information Systems”

Spring – 2024 (2<sup>nd</sup> Sem. 1445H)

Chapter 4:

***Structured Analysis and Functional***

***Architecture Design – p1 – IDEF0 – i - Fundamentals***

Prepared by: Ahmed M. El-Sherbeeney, PhD

# Lesson Overview

- [Modeling IIS – \(p1\)](#)
- [Integrated Computer-Aided Manufacturing Definition 0 \(IDEF0\) – \(p1\)](#)
- Data Flow Diagram (DFD) – (p2)

# Modeling Industrial Information Systems



# Modeling IIS

- **REMEMBER: Design** – a description of the recommended solution is converted into *logical* and then *physical* system specifications
  - **Logical design:** all *functional features* of the system chosen for development in analysis are described *independently* of any computer platform
  - **Physical design:** transforming the logical specifications of the system into *technology-specific details*

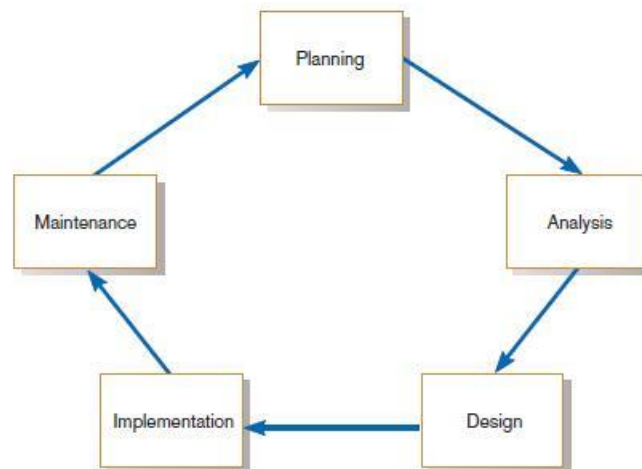

# Modeling IIS – cont.

- This is *first step* in design of IIS for an industrial enterprise
- The design proceeds from a **definition of a business model** of the enterprise
- This business model (**IS model**) is a description of the:
  - **functions of the business** (or manufacturing operations)
  - **data requirements**, and
  - **interactions** between the functions and data requirements

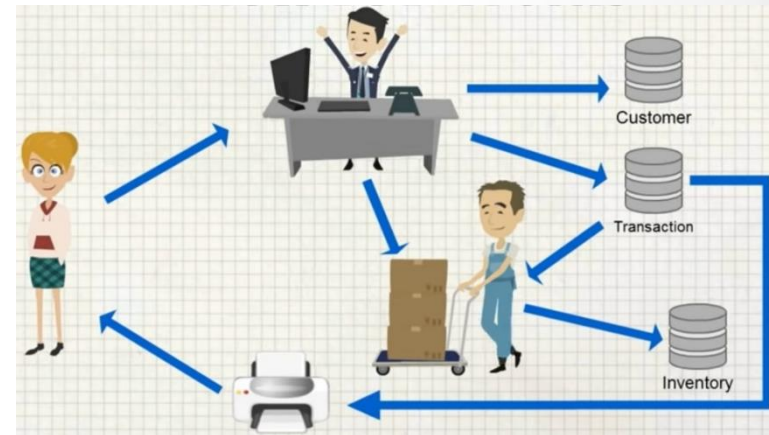

# Modeling IIS – cont.

- **Functional or Activity architecture** describes:
  - a conceptual model of the activities that operate the business (or manufacturing operations) *and*
  - the relationships between those activities
- The word **architecture** denotes the fact that the model has a *layered structure*
- A related conceptual model of the firm is the **Informational or Data architecture**:
  - this is a model of the *information requirements* needed to perform the functions of the business

# Modeling IIS – cont.

- Functional and informational architectures, when taken together:
  - form a *high-level blueprint* for the implementation of computer integration in the enterprise

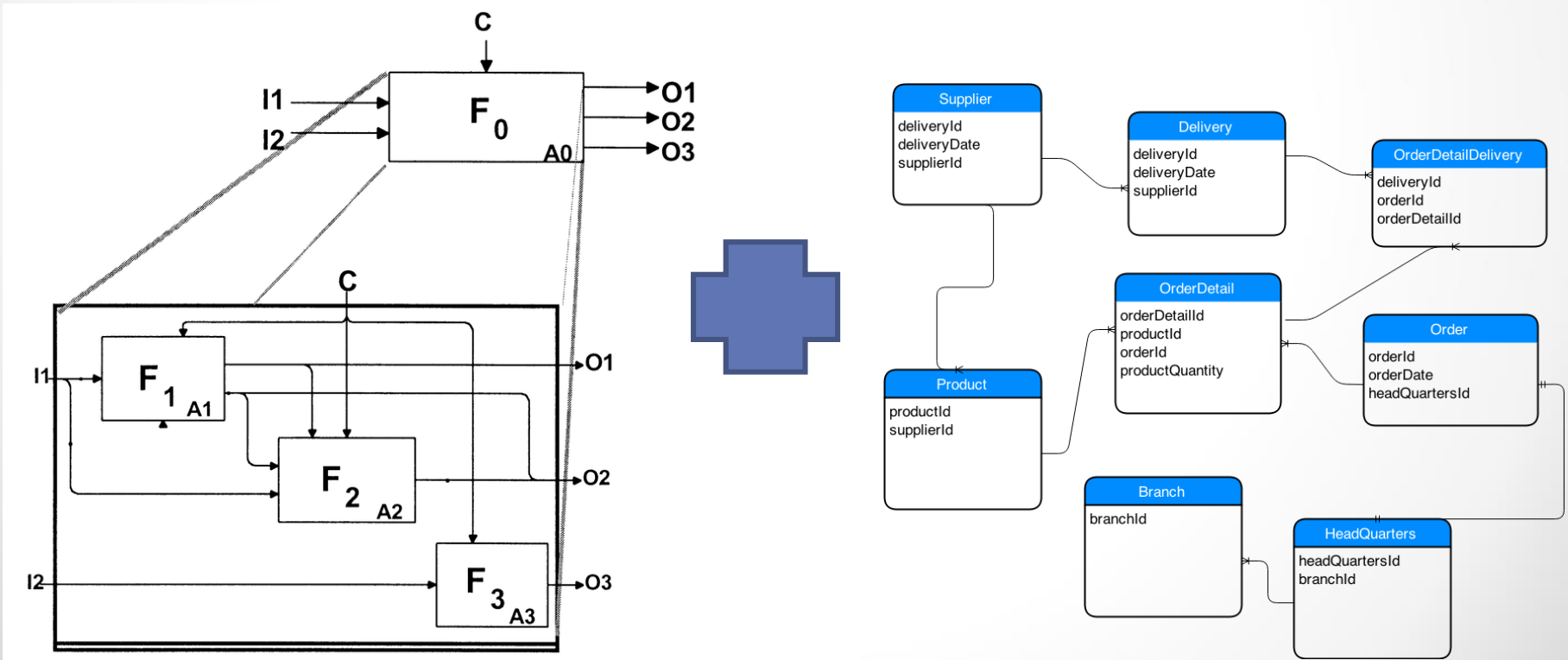

# Modeling IIS – cont.

- There are **three layers** of system design to consider in an information system project:
  - Conceptual
  - Implementation and
  - Execution
- Conceptual layer consists of **logical** design of functional and data requirements

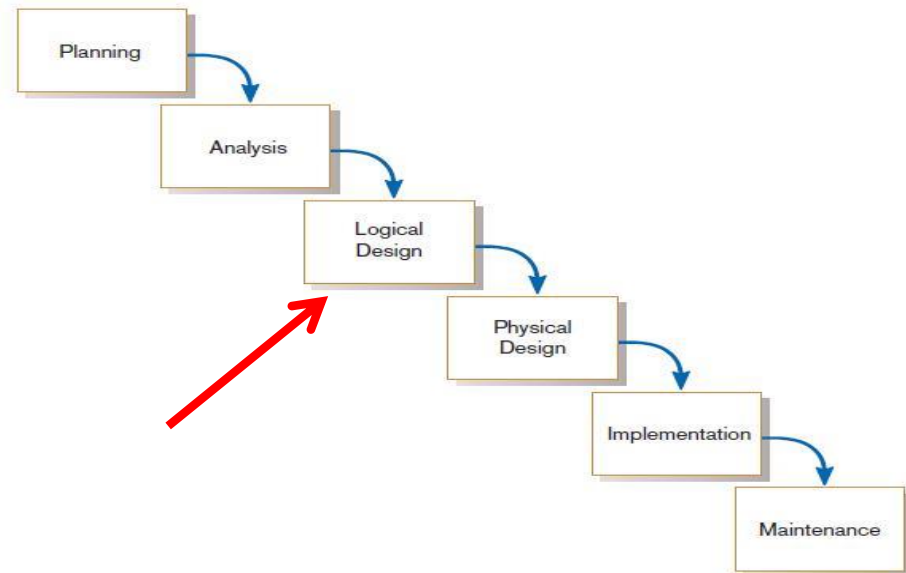



# Layers of IS Design Process

## Conceptual Layer

Functional  
Architecture

Informational  
Architecture

## Implementation Layer

- Software Environment
- Platform Hardware
- Network Architecture

## Execution Layer

- Database Management System
- Forms and Reports

# Modeling IIS – cont.

- When a conceptual design is complete, the next step is to **implement** the blueprint as hardware and software
- This is the *implementation layer* that requires the selection of:
  - database management system (DBMS)
  - hardware platforms, and
  - communication medium

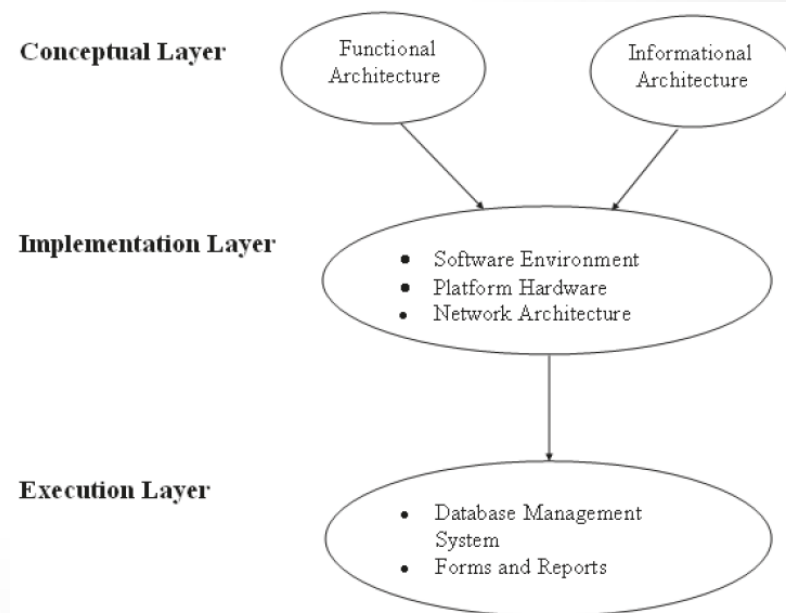

# Modeling IIS – cont.

- At the **execution** layer, the conceptual model and implementation techniques are coded in **software** in terms of forms and reports
- *Forms and reports* are used to interface with the individuals performing the functions defined in the functional architecture

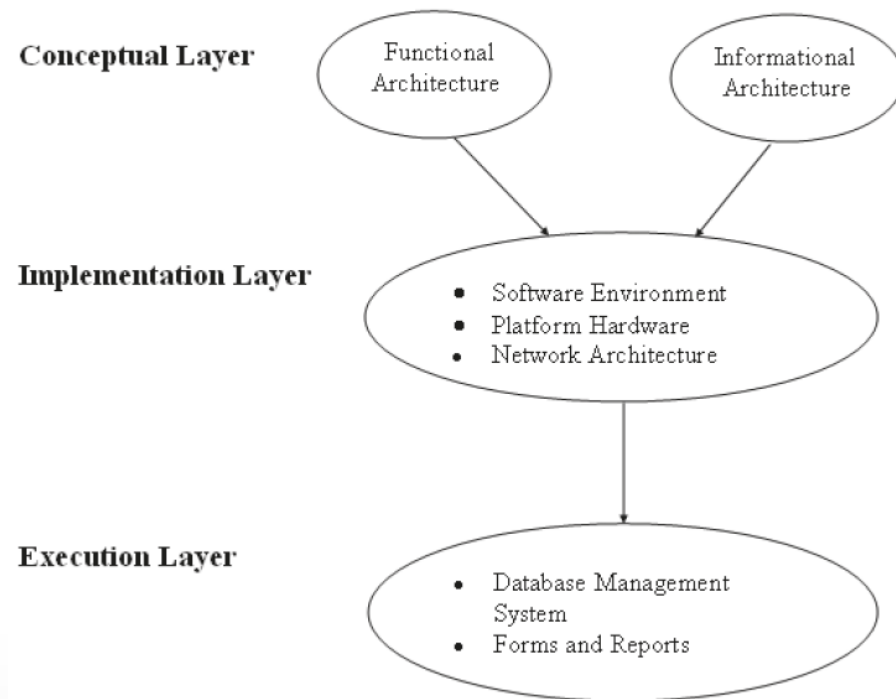

# Modeling IIS – cont.

- Two methodologies for designing a functional architecture, known as “structured analysis” techniques:
  - **data flow diagrams** (1979), widely used by information system professionals in all industries
  - **structured analysis and design technique** (SADT) (1988), adapted for manufacturing enterprises under the name **integrated computer-aided manufacturing definition 0** (IDEF0)
  - Both methodologies are based on *graphical notations* used to describe information flows among processes of the enterprise being documented (described next)

# Functional Modeling

## Integrated Computer-Aided Manufacturing Definition 0 (IDEF0)



# IDEF Family

- **IDEF Family of Methods:**
  - IDEF0: Function Modeling (purpose: description)
  - IDEF1: Information Modeling (purpose: description)
  - IDEF1x: Data Modeling (purpose: design)
  - IDEF2, IDEF3: Process Modeling (purpose: description)
  - IDEF4: for Object-Oriented Programming (purpose: design)
  - Other: IDEF5, IDEF6, IDEF8, IDEF9, IDEF14

# IDEF0 Methodology - Modeling Primitives

- **IDEF0 (integrated computer-aided manufacturing definition 0):**
  - modeling methodology
  - used for designing and documenting **hierarchical, layered, modular systems**
- The **activity box**:
  - used to describe a *function being performed* in the enterprise
- Function can be either a:
  - *material conversion* function (e.g. machining a part), or
  - *information conversion* function (e.g. processing a requisition for ordering materials)

# IDEF0 Activity Box and Connecting Arrows

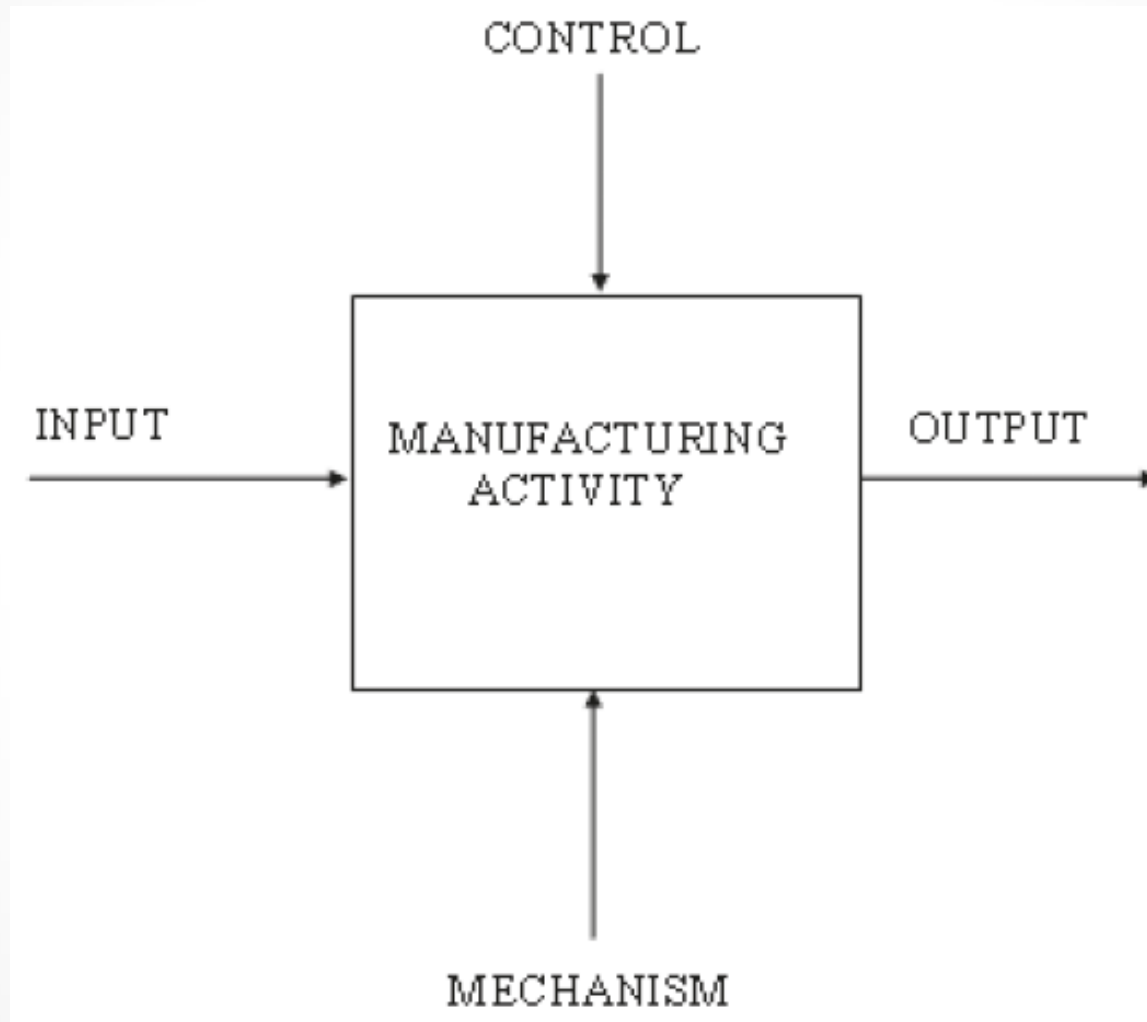



# IDEF0 Activity

- **Inputs:** items that are transformed by the function
  - a workpiece to be machined, or
  - requisition information to be transformed into a purchase order
- **Outputs:** result of the transformation process provided by the activity
  - finished component after machining, or
  - a purchase order

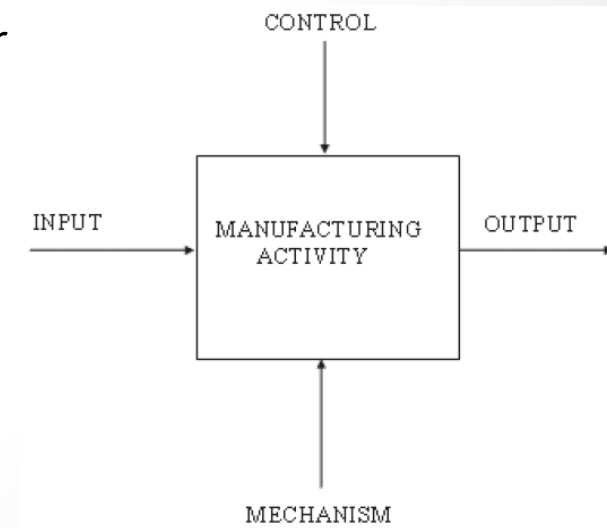

# IDEF0 Activity – cont.

- **Mechanisms:** means by which a function is realized
- Mechanism in material conversion of a workpiece to a finished component might require (as mechanisms):
  - a *lathe* and
  - *lathe operator*
- Information conversion to process a requisition into a purchase order:
  - Could involve a *purchasing agent* as the mechanism

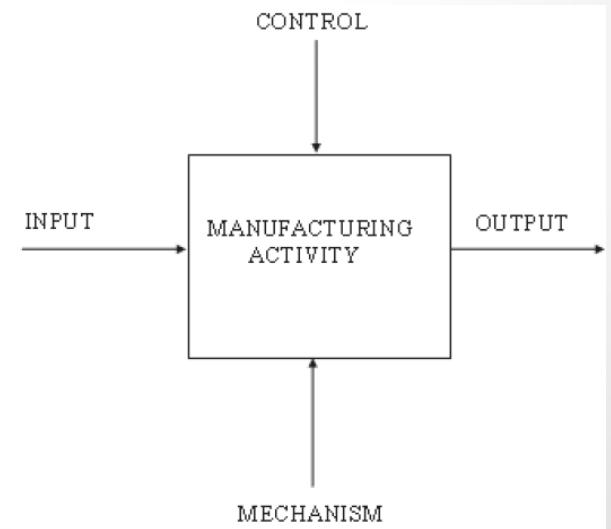

# IDEF0 Activity – cont.

- A **control** is a condition or set of conditions that *guide* or *constrain* the performance of the activity
- *Machining activity* example:
  - parts may require a *numerical control parts program*
- *Information conversion* example:
  - requisition processing function may require adherence to *set of company rules or purchasing policy*
  - e.g. purchasing only from approved vendors

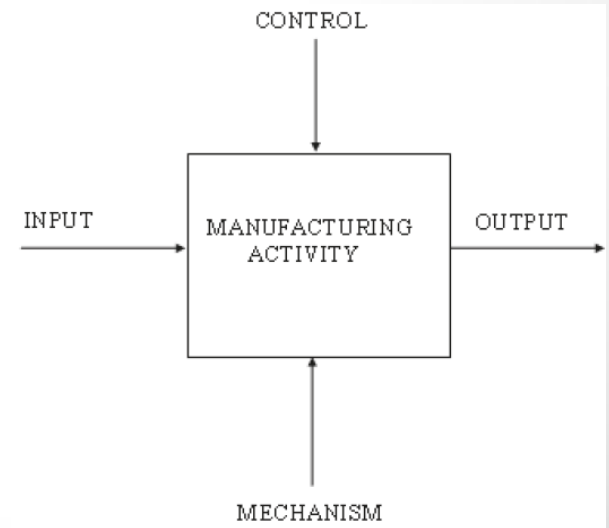

# IDEF0 Activity – cont.

- **Activity box** and 4 **arcs** provide a concise expression:
  - an **input** is transformed ...
  - into an **output** ...
  - by an **activity (function)** ...
  - performed by a **mechanism** ...
  - and governed by a **control**

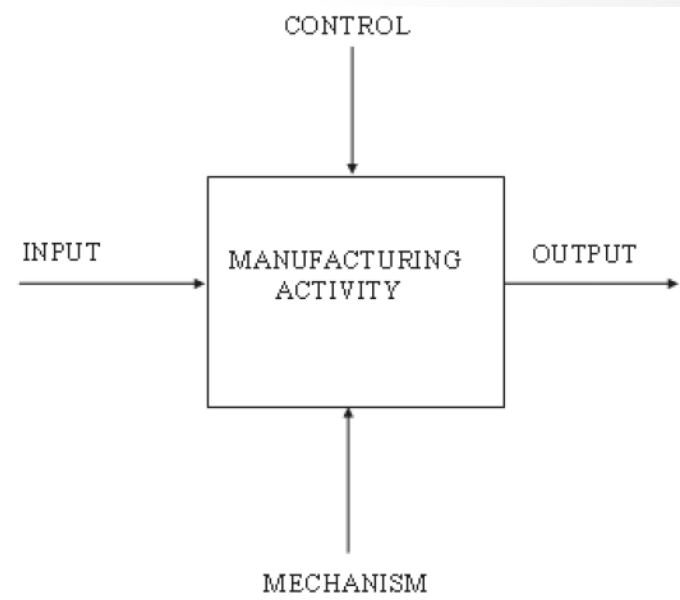

- The specific activity, inputs, outputs, mechanisms, and controls are defined by the *situation* being modeled

# IDEF0 Activity – cont.

- **Grammatical convention** used in naming activities and arcs:
  - **Activities** represent *actions* being performed and are labeled with *verb phrases*
  - **Inputs, outputs, mechanisms, and controls** represent things and are labeled with *noun phrases*

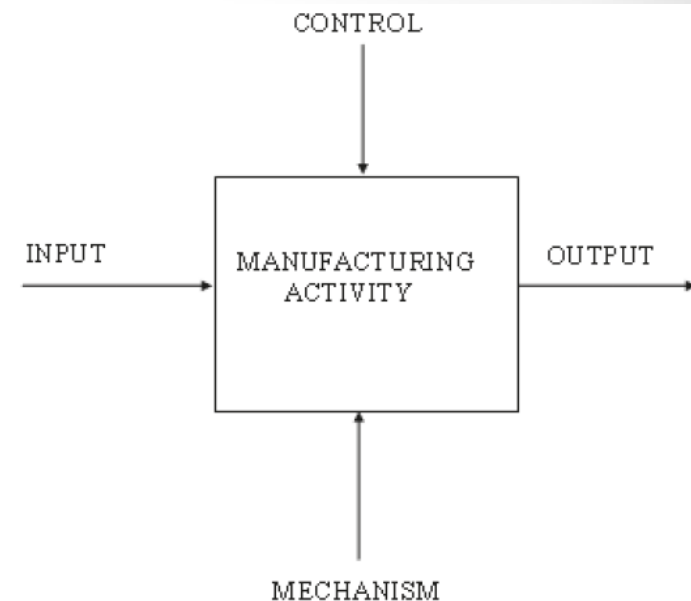

# IDEF0 Hierarchic decomposition

- IDEF0 is a top-down modeling approach
- *First layer:*
  - a **single activity box**
  - describes the *overall function* of the enterprise, organization, or process within the enterprise (i.e. the subject of the model)
- This overall activity is then decomposed into its *major sub-activities* at the *second layer*
- Functions are related to each other by their **material flows** and **information flows**
  - e.g. the *output* material or information of one activity may provide the *input* to another activity

# IDEF0 Activity – cont.

- Relationship among levels in IDEF0 methodology e.g. 1

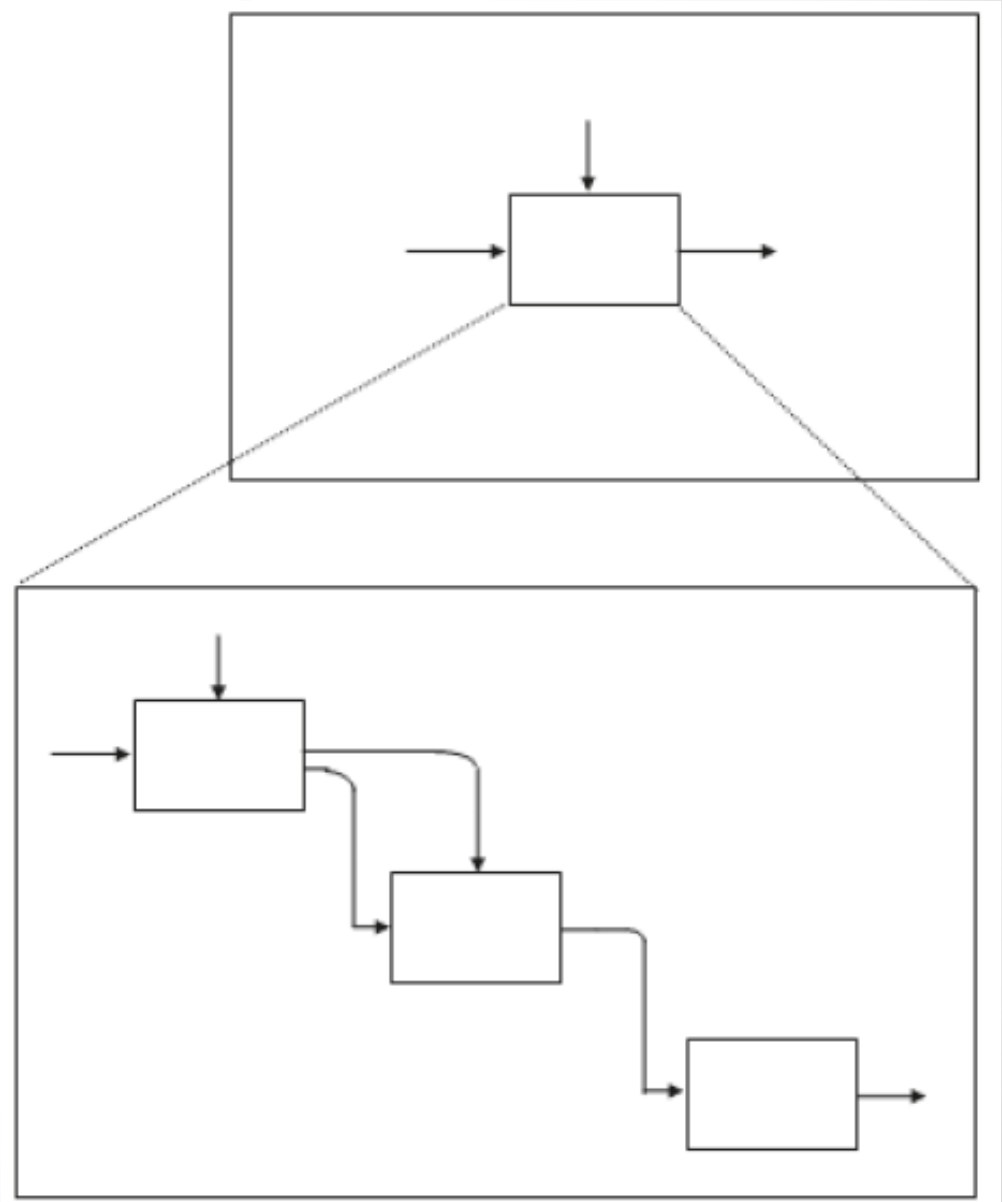

# IDEF0 Activity – cont.

- e.g. 2

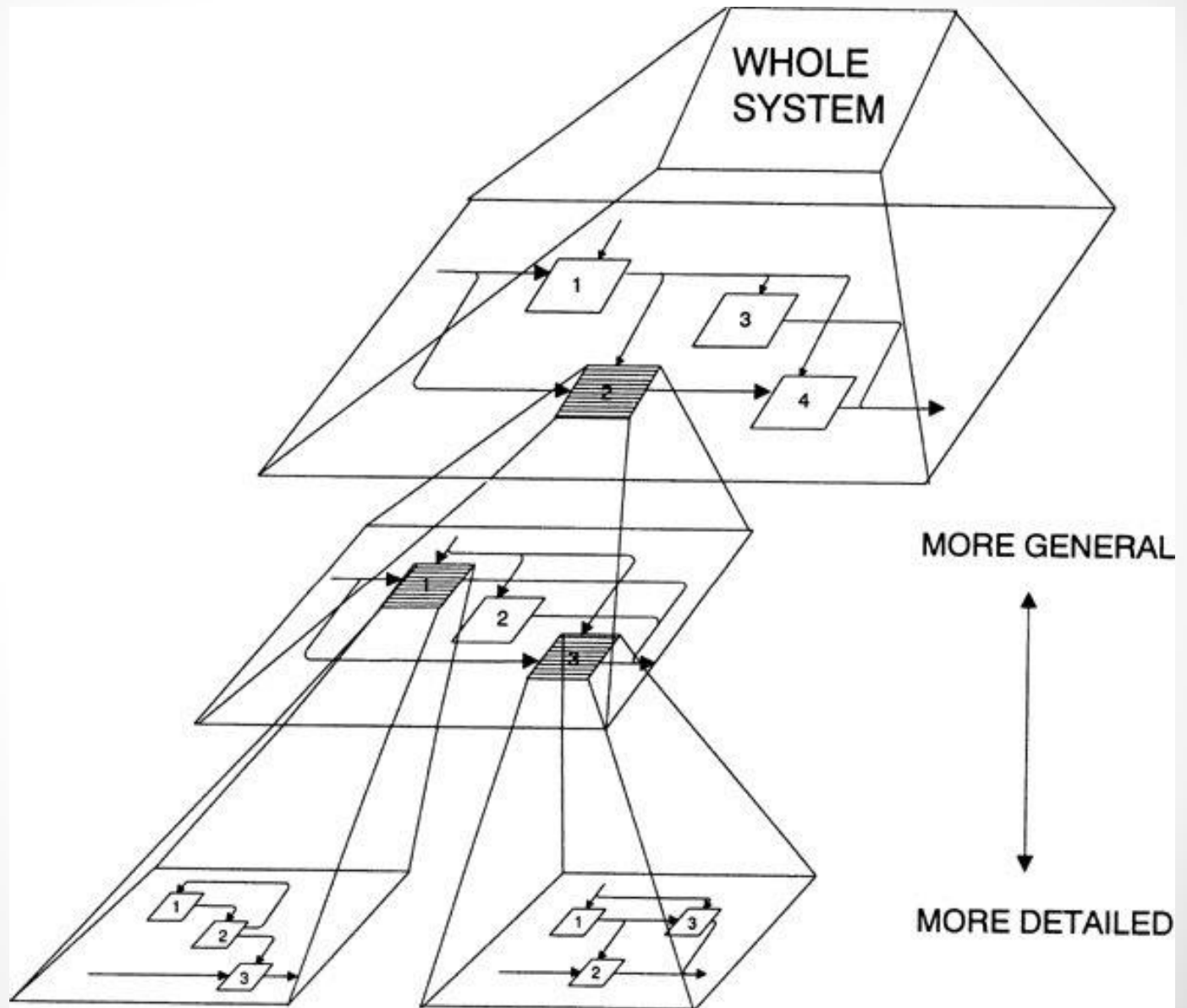



# IDEF0 Activity – cont.

- e.g. 3

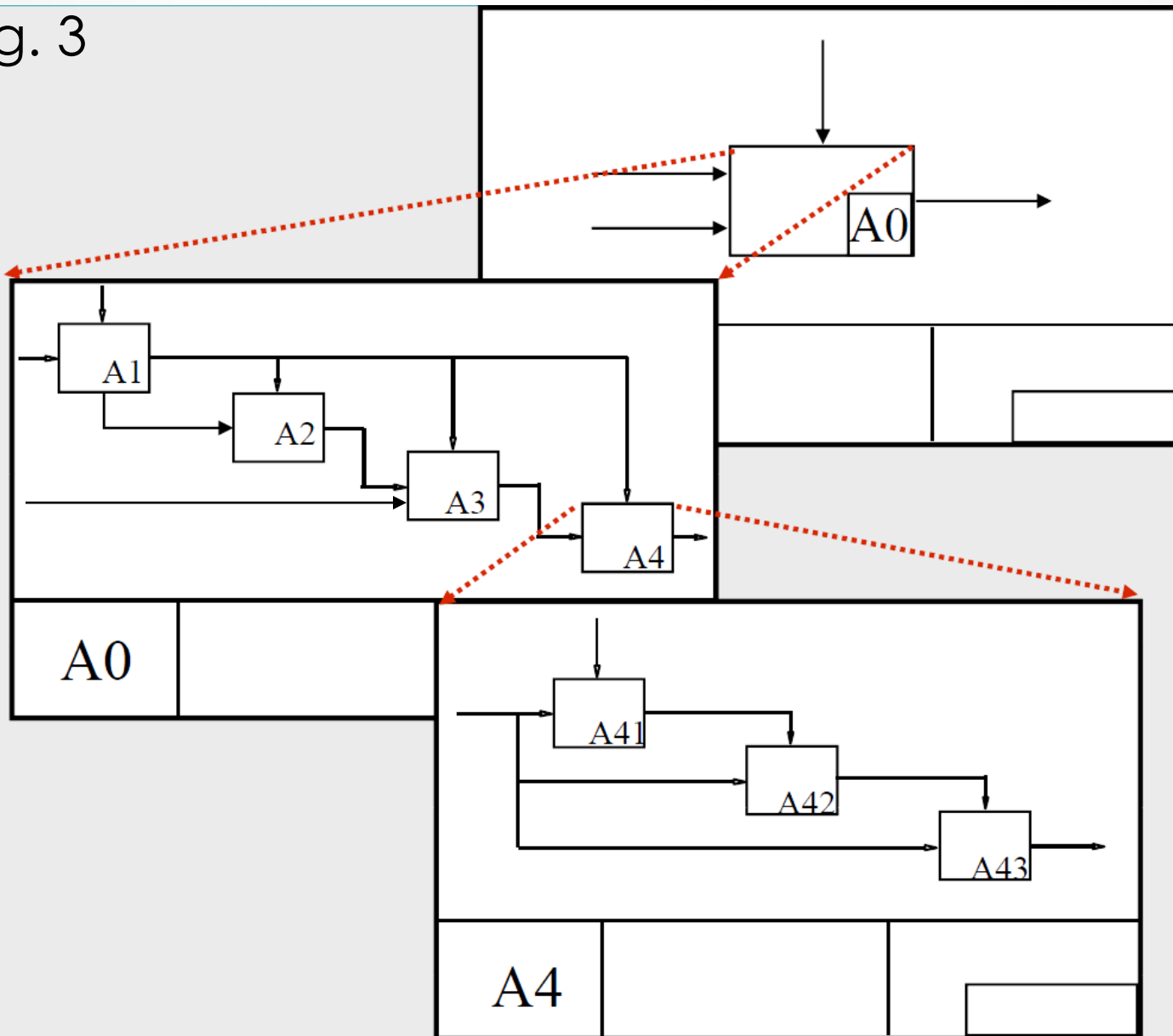

# An Integrated IDEF0 Model of an Entire Manufacturing Enterprise

- Top-level view of the enterprise: Node A0

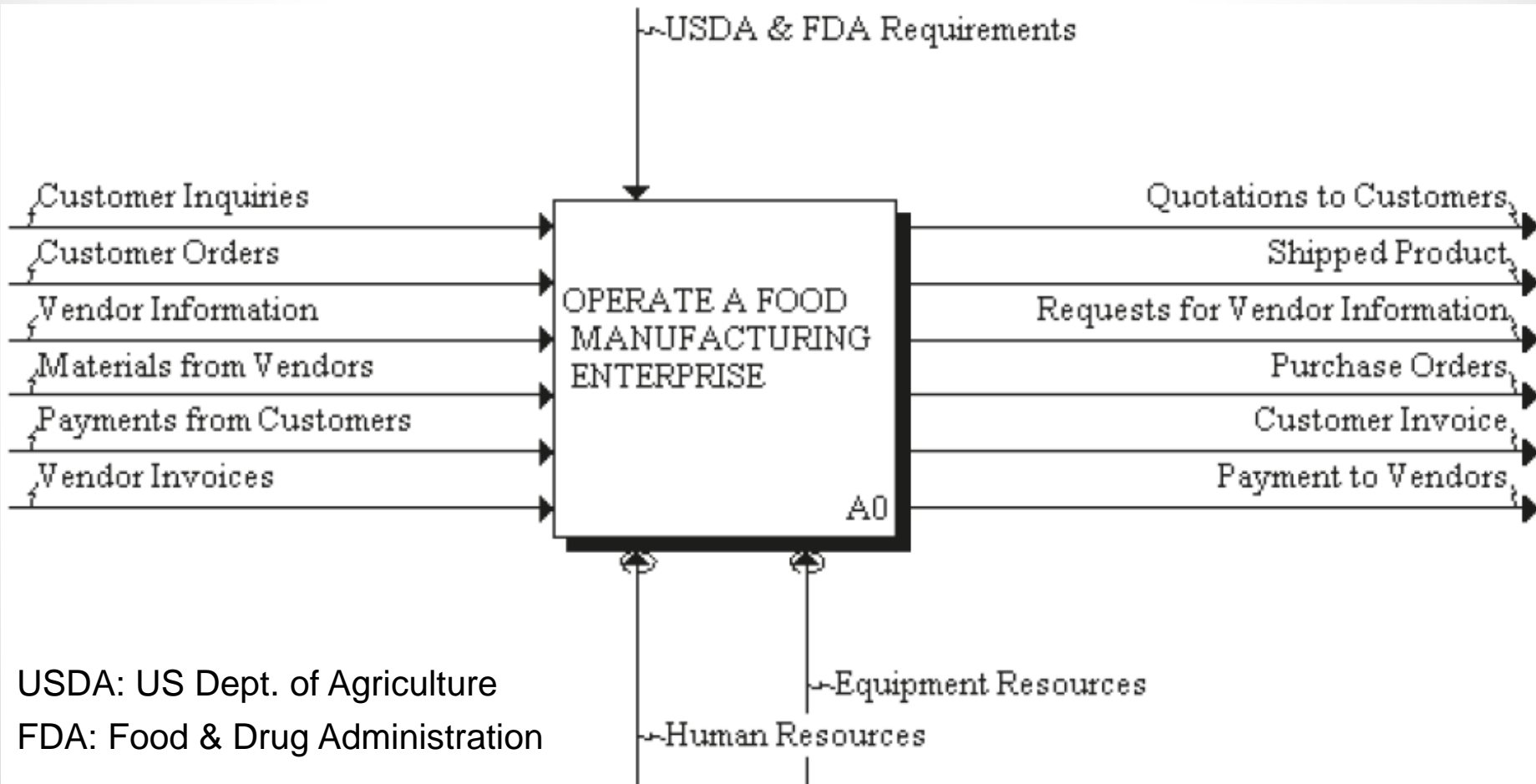

# Elements of the A0 Activity

- **A0**: high-level view of the enterprise and its interactions with the outside world
- Related Inputs (I) and Outputs (O):
  - Customer inquiries (I)  $\Rightarrow$  Quotations to customers (O)
  - Customer orders (I)  $\Rightarrow$  Shipped product (O)
  - Customer invoice (O)  $\Rightarrow$  Payments from customers (I)
  - Request for vendor information (O)  $\Rightarrow$  Vendor information (I)
  - Purchase orders (O)  $\Rightarrow$  Materials from vendors (I)
  - Vendor invoice (I)  $\Rightarrow$  Payments to vendors (O)

# Elements of the A0 Activity – cont.

- In summary: operation of a manufacturing enterprise can be viewed as 3 *interrelated processes*:
  1. **Physical flow of materials**; e.g. input materials from vendors is transformed (i.e. the manufacturing process) into the output shipped product
  2. **Information flow**; e.g. vendor information and quotation to customers
  3. **Financial flow**; e.g. payments from customers and payments to vendors
- Outside **controls**: USDA, FDA (important class of standards)
- **Mechanisms**: human resources and equipment
  - resources; these *convert* inputs to outputs

# Decomposition of Node A0

- Decomposing node A0 identifies four major activities at the next level ([next slide](#)):

- A1: Manage Sales and Orders Process,
- A2: Plan for Manufacture,
- A3: Manufacture Product, and
- A4: Control Finished Goods

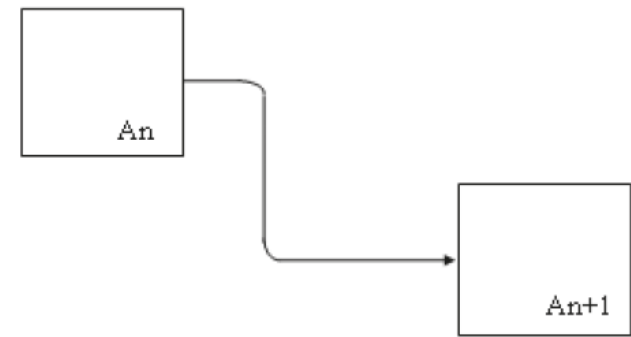

Simple output/input relationship

- Inputs and outputs of the *parent* activity are **inherited** by the *child*)
  - e.g. [customer inquiries](#) and [customer orders](#) are handled by the sales organization and are inputs to [node A1](#)
  - e.g. [finished product](#) leaves the enterprise from finished goods inventory (shown as an output of activity [A4](#))

# Decomposition of Node A0 – cont.

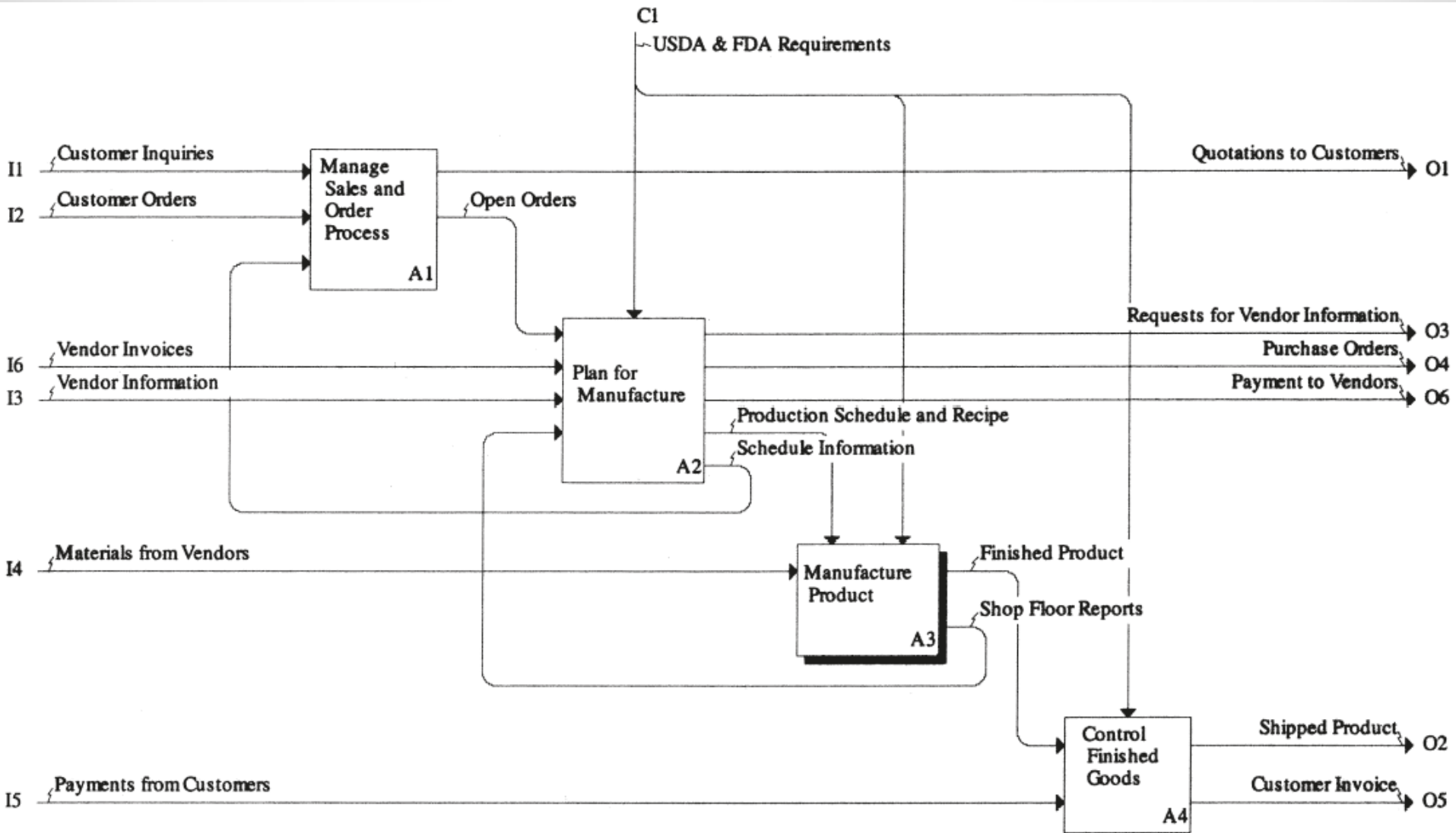

# Decomposition of Node A0 – cont.

- Note the *activity flow relationship*:
  - When several activity boxes are drawn at the *same level* of decomposition, they are ordered by *sequential order/dominance*
    - e.g. “[Manage Sales and Order Processes](#)” activity precedes “Plan for Manufacture” activity, etc.
  - For ease of diagramming, IDEF0 methodology recommends using a *staircase pattern* whenever possible
  - Also recommended: at each level of decomposition, from *three to six child* activities be created from each *parent*

## Decomposition of Node A0 – cont.

- Decomposition of a parent activity is determined by the analyst in conjunction with enterprise personnel
- The *breakdown structure* of an activity into its main child activities is usually written in an *indented list*
- The following indented list applies at this point:
  - A0 — Operate a Food Manufacturing Enterprise
    - A1 — Manage Sales and Orders Process
    - A2 — Plan for Manufacture
    - A3 — Manufacture Product
    - A4 — Control Finished Goods



# Connecting flows between activities

- **Parallelism:** simultaneous flow to more than one activity
- This is more common with a *flow of information* than with a *flow of physical entities*

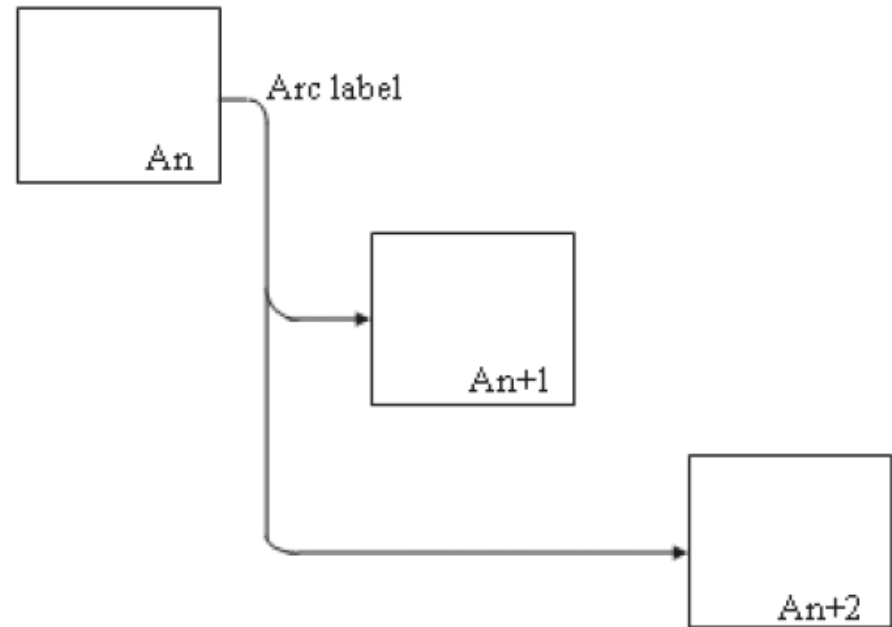

# Connecting flows between activities – cont.

- **Distribution of flows** to more than one activity

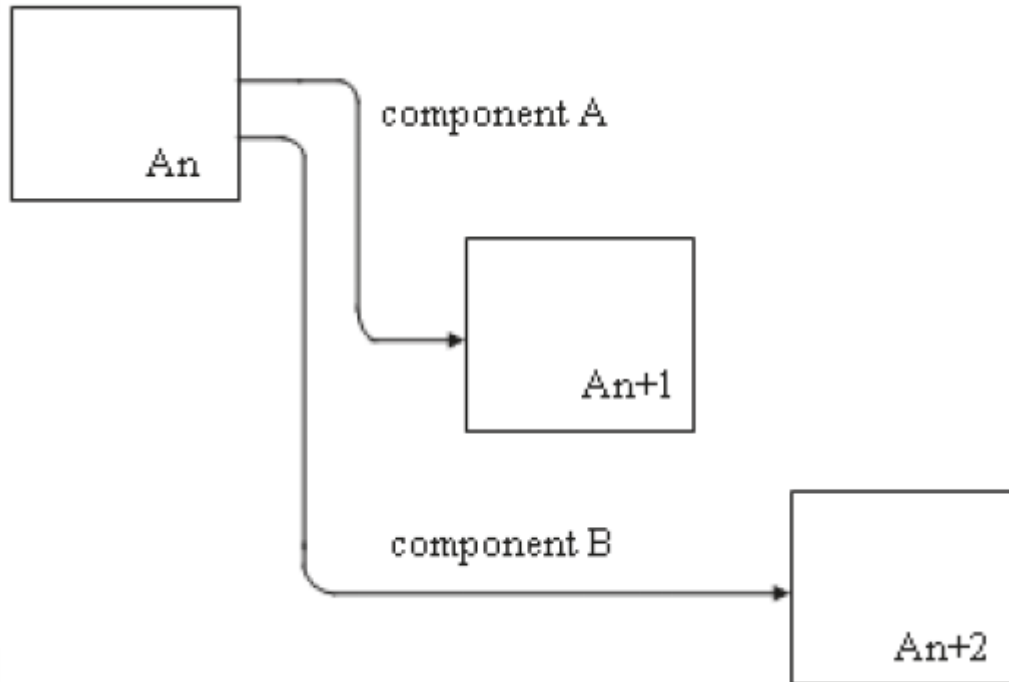

# Connecting flows between activities – cont.

- One activity can provide inputs, controls, or both to other activities

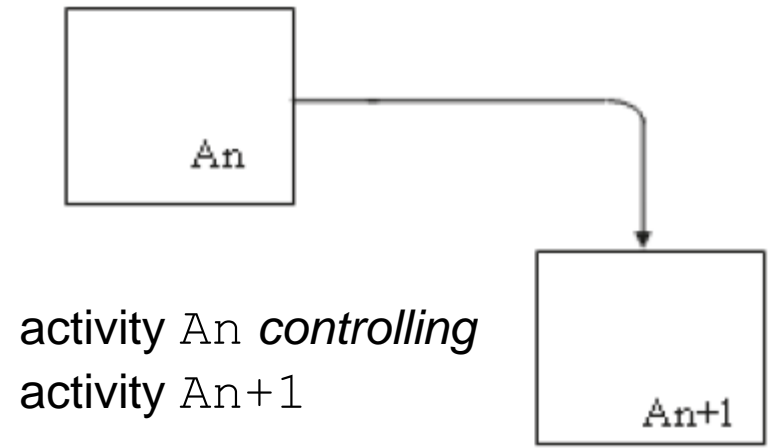
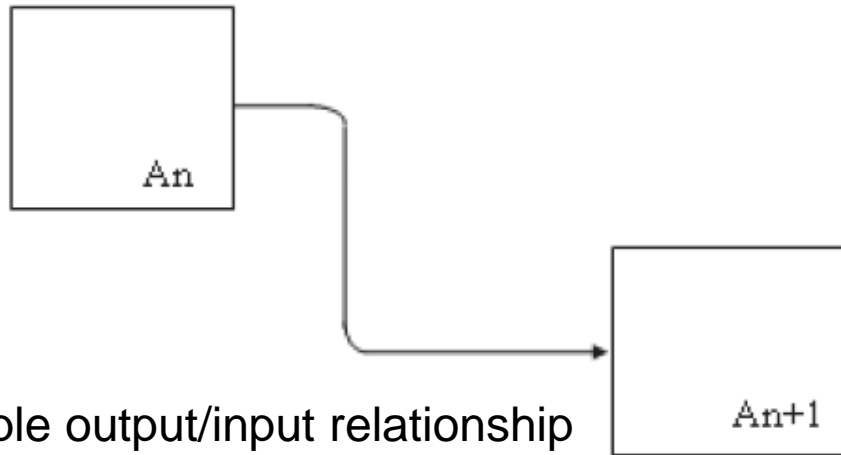

# Connecting flows between activities – cont.

- Q: how to avoid confusion in deciding whether an arc is either an *input* to an activity or a *control*?
  - If entity represented by arc is **converted** into some other form by the activity, it is clearly an **input**
  - e.g. activity [A4](#) converts *finished product* into *shipped product*

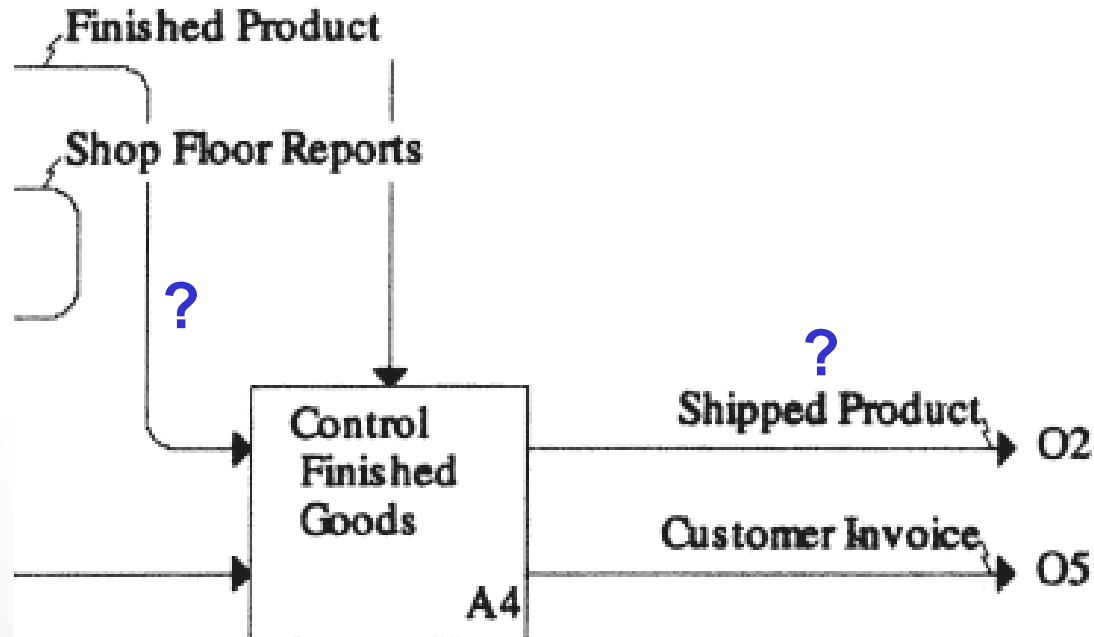

# Connecting flows between activities – cont.

- Q: how to avoid confusion in deciding whether an arc is either an *input* to an activity or a *control*? (cont.)
  - If entity represented by arc **directs** the activity as to *how* it will perform its function, it is clearly a **control**
  - e.g. “*production schedule and recipe*” is information that *tells* activity [A3](#) what products will be produced on a specific day (production schedule) *and* how these products will be produced (recipe)

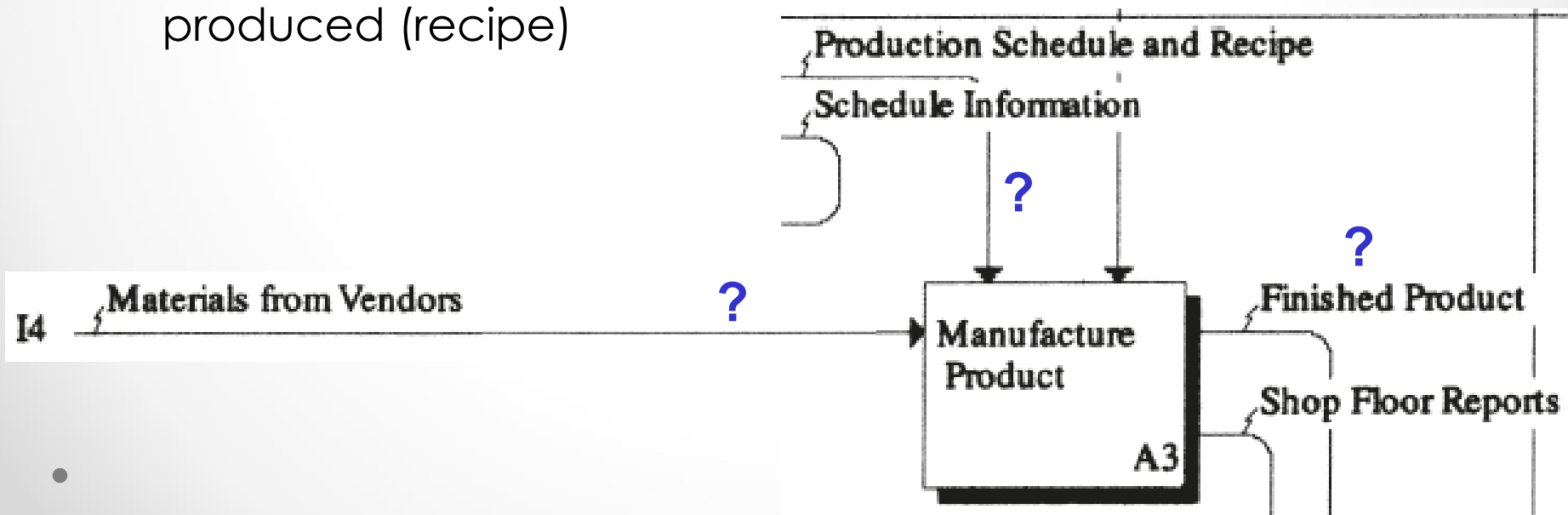

# Connecting flows between activities – cont.

- **Feedback:** occurs when information generated in a subsequent activity is used by a prior activity in the activity diagram
  - e.g. relationship between [A1: Manage Sales and Order Process](#) and [A2: Plan for Manufacture](#) (i.e. to know delivery dates for customer quotation, you must know planned mfg. schedule)\*

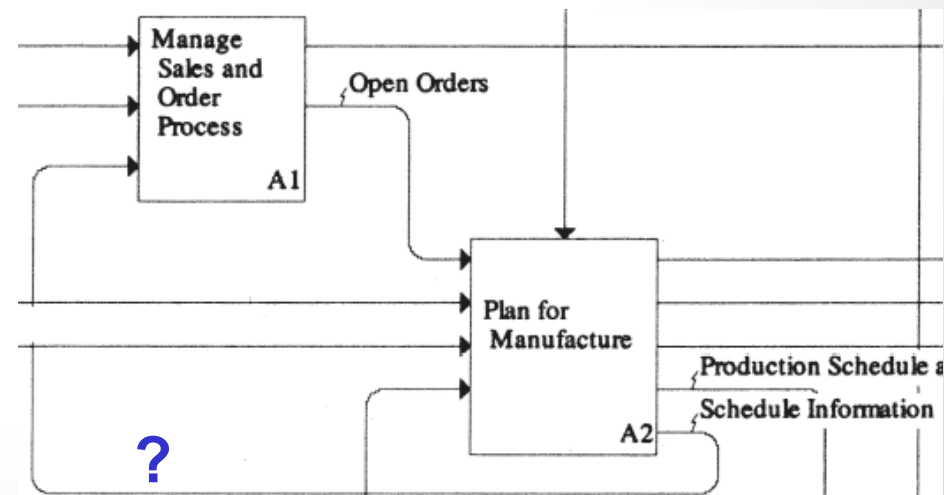
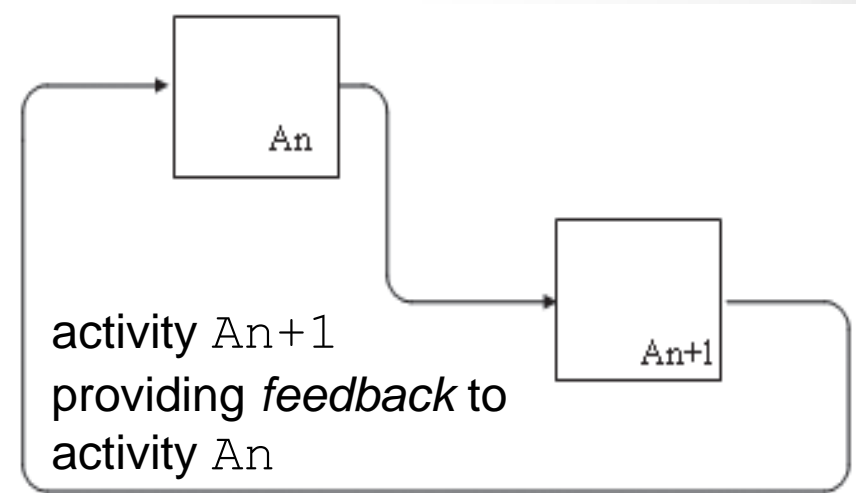

# Connecting flows between activities – cont.

- Note, we have not shown *mechanisms* in the decomposition of node A0
- Mechanisms are only required at the **elemental level** of the modeling process (i.e. when a specific activity is identified at the *lowest level* of the hierarchy)

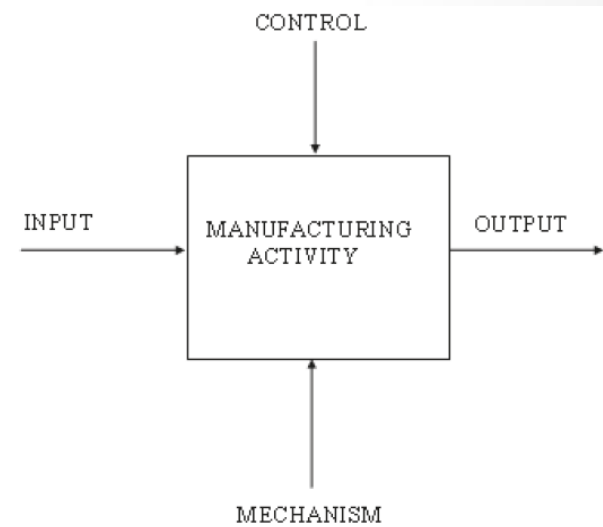

# Sources

- [Design of Industrial Information Systems](#). Thomas Boucher, and Ali Yalcin. Academic Press. First Ed. 2006. Chapter 4.
- Some useful videos:
  - Function modelling using IDEF0: The basics of functions, inputs, outputs, mechanisms and controls (<https://youtu.be/xyO5n6Ay-1I>)
  - AI0Win Tutorial – “Manage a Coffee Shop” (<https://youtu.be/kHDNIFclsiY>)