



(12) **United States Patent**  
**Alzain**

(10) **Patent No.:** **US 10,314,672 B2**  
(45) **Date of Patent:** **Jun. 11, 2019**

(54) **CHEEK AND TONGUE RETRACTOR**

(71) Applicant: **KING SAUD UNIVERSITY**, Riyadh (SA)  
(72) Inventor: **Sahar Asaad Alzain**, Riyadh (SA)  
(73) Assignee: **King Saud University**, Riyadh (SA)  
(\* ) Notice: Subject to any disclaimer, the term of this patent is extended or adjusted under 35 U.S.C. 154(b) by 0 days.

2,831,480 A	4/1958	Milano	
5,071,347 A	12/1991	McGuire	
5,503,556 A *	4/1996	Leonard	A61C 5/82 433/139
5,800,173 A *	9/1998	Heasley	A61C 5/90 433/136
5,890,899 A	4/1999	Sclafani	
6,213,772 B1	4/2001	Costello	
D491,663 S *	6/2004	Bat-Genstein	D24/176
6,939,134 B2	9/2005	Sherry et al.	
2004/0209224 A1 *	10/2004	Heasley	A61C 5/82 433/139

(21) Appl. No.: **15/801,222**  
(22) Filed: **Nov. 1, 2017**

(65) **Prior Publication Data**  
US 2019/0125491 A1 May 2, 2019

(51) **Int. Cl.**  
*A61C 5/90* (2017.01)  
*A61B 13/00* (2006.01)  
*A61C 5/80* (2017.01)  
*A61B 1/24* (2006.01)

(52) **U.S. Cl.**  
CPC ..... *A61C 5/90* (2017.02); *A61B 13/00* (2013.01); *A61B 1/24* (2013.01); *A61C 5/80* (2017.02)

(58) **Field of Classification Search**  
CPC .... *A61C 5/80*; *A61C 5/82*; *A61C 5/85*; *A61C 5/88*; *A61C 5/90*; *A61B 13/00*; *A61B 1/24*  
See application file for complete search history.

(56) **References Cited**  
U.S. PATENT DOCUMENTS

730,184 A	6/1903	Witter
2,125,980 A	8/1938	Basil

FOREIGN PATENT DOCUMENTS

CA 2298336 A1 8/2001

OTHER PUBLICATIONS

“Rubber Dam Clamps,” Hu-Friedy website: <https://www.hu-friedy.com/products/mastercontrol/index/file/id/32>, © 2012.

\* cited by examiner

*Primary Examiner* — Edward Moran  
*Assistant Examiner* — Drew S Folgmann  
(74) *Attorney, Agent, or Firm* — Richard C. Litman

(57) **ABSTRACT**

The retractor is a generally U-shaped device for protecting the cheek and tongue from instruments used during dental and prosthodontic procedures. The retractor has a planar base defined by two spaced arms, a pair of upright shields extending from the arms, and a posterior connector connecting the shields. The base is contoured to grip the tooth adjacent to the tooth to be treated, and thereby, secure the retractor within the patient’s mouth.

**5 Claims, 4 Drawing Sheets**

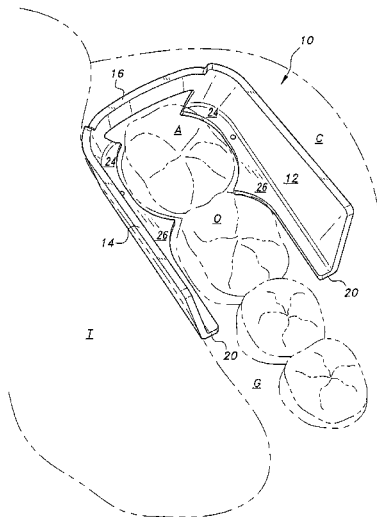



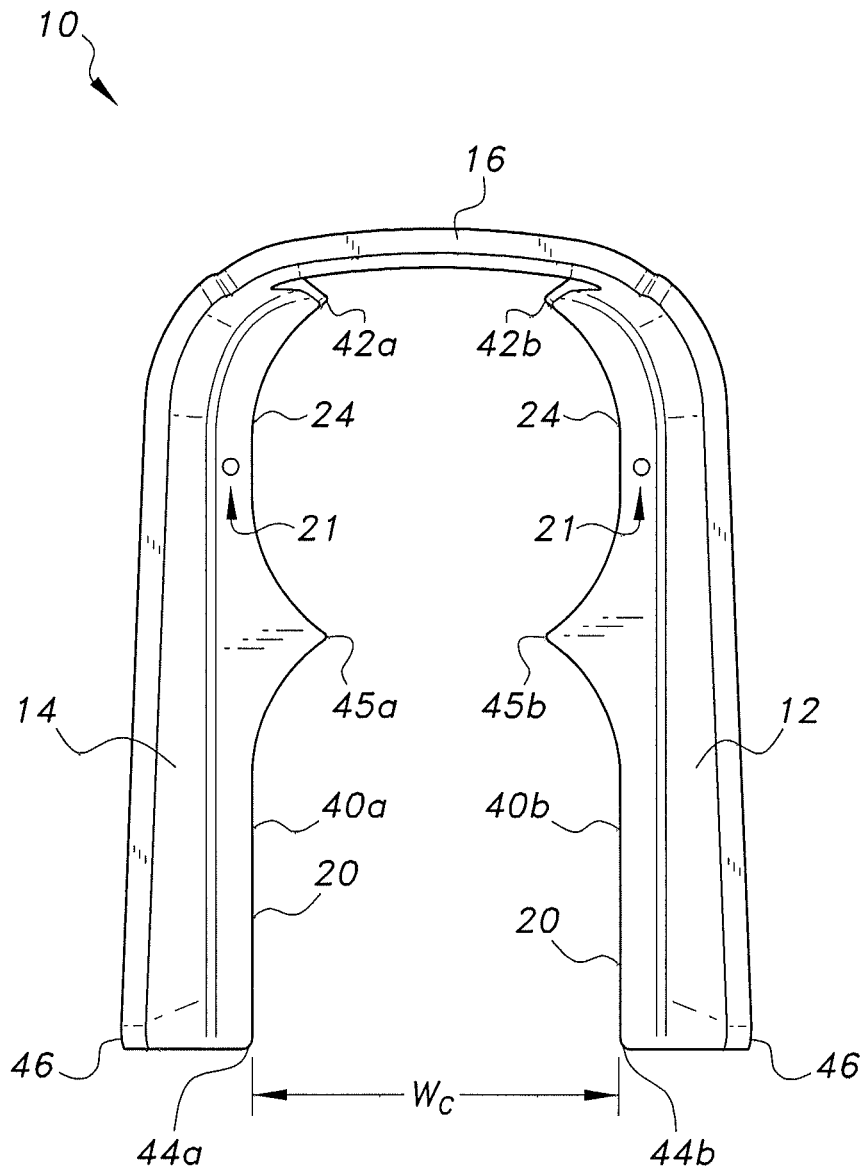

FIG. 2

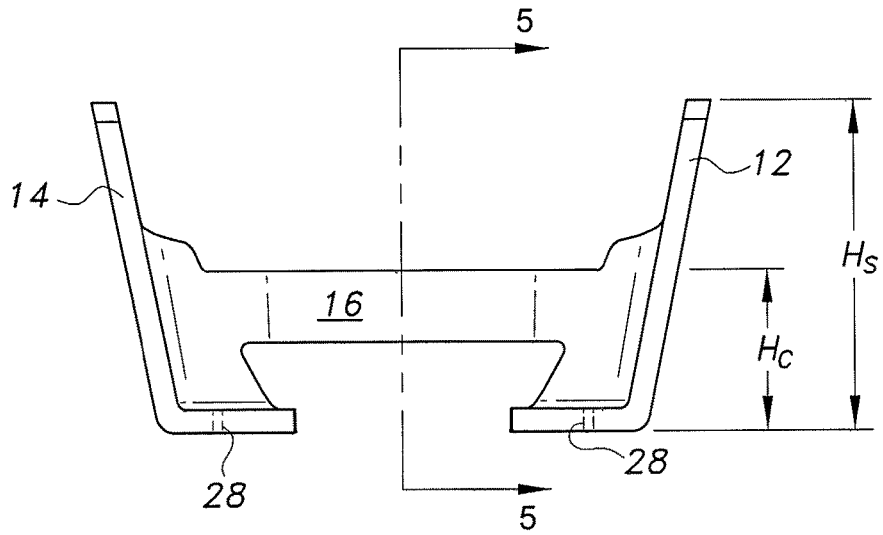

FIG. 3

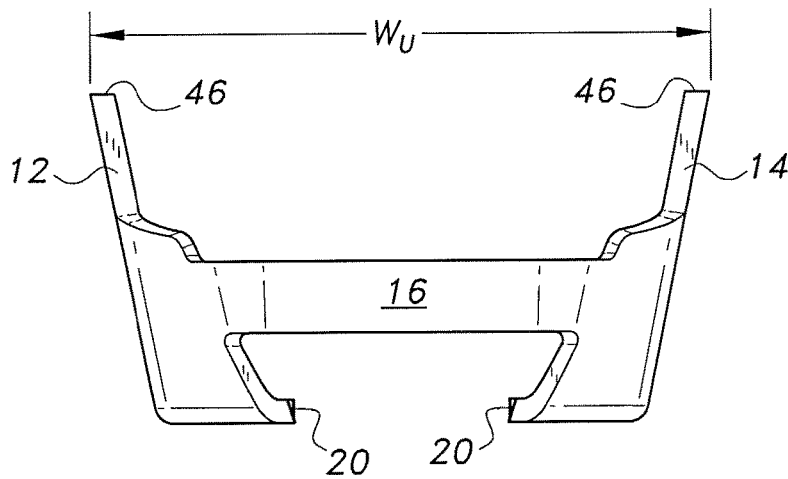

FIG. 4

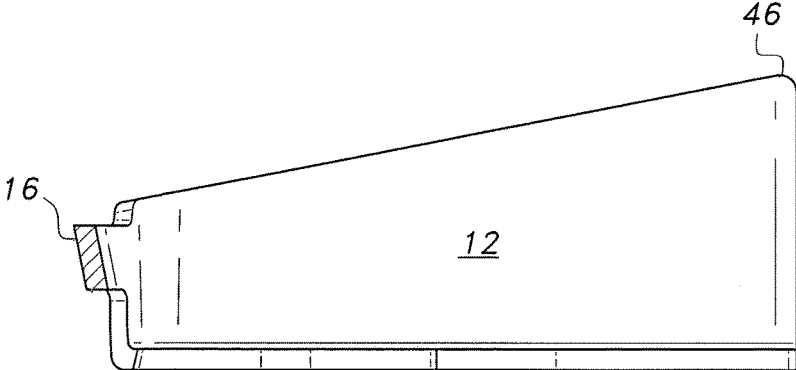

FIG. 5

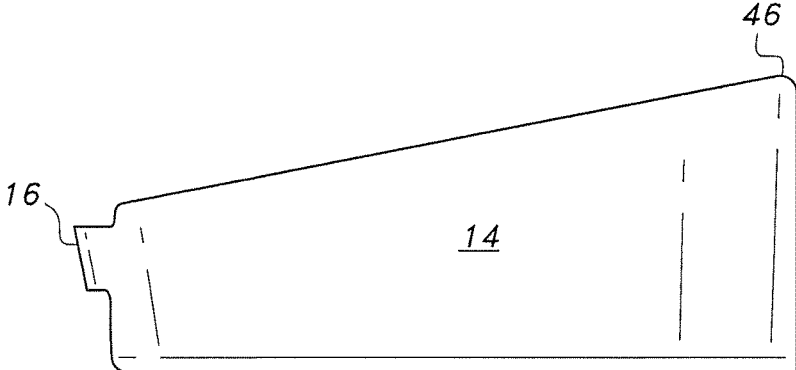

FIG. 6

## CHEEK AND TONGUE RETRACTOR

## BACKGROUND

## 1. Field

The disclosure of the present patent application relates to dental appliances, and particularly to a cheek and tongue retractor for restorative and prosthodontic treatment.

## 2. Description of the Related Art

During restorative dentistry and prosthodontic procedures, clinicians are often required to utilize carbide and/or diamond burs for drilling, finishing, and/or grinding at high speeds. To protect the tongue and cheek of the patient during these procedures, clinicians typically use cheek and tongue retractors. Many conventional retractors, however, include hinged joints, mirrors, and/or handles, which can block or minimize a work area in the mouth. Further, the clinician must grasp a retractor handle to maintain the retractor in a desired position during the procedure. As such, conventional retractors can also be difficult to use.

Thus, a cheek and tongue retractor for restorative and prosthodontic treatment solving the aforementioned problems is desired.

## SUMMARY

The retractor is a generally U-shaped device for protecting the cheek and tongue from instruments used during dental and prosthodontic procedures. The retractor has a planar base defined by two spaced arms, a pair of upright shields extending from the arms, and a posterior connector connecting the shields. The base is contoured to grip the tooth adjacent to the tooth to be treated, and thereby, secure the retractor within the patient's mouth.

These and other features of the present disclosure will become readily apparent upon further review of the following specification and drawings.

## BRIEF DESCRIPTION OF THE DRAWINGS

FIG. 1 is an environmental, perspective view of a cheek and tongue retractor for restorative and prosthodontic treatment.

FIG. 2 is a plan view of the cheek and tongue retractor of FIG. 1.

FIG. 3 is a front view of the cheek and tongue retractor of FIG. 1.

FIG. 4 is a rear view of the cheek and tongue retractor of FIG. 1.

FIG. 5 is a section view drawn along lines 5-5 of FIG. 3.

FIG. 6 is a left side view of the cheek and tongue retractor of FIG. 1.

Similar reference characters denote corresponding features consistently throughout the attached drawings.

## DETAILED DESCRIPTION OF THE PREFERRED EMBODIMENTS

The cheek and tongue retractor **10** can be used to protect the cheek and tongue from instruments used during dental and prosthodontic procedures. As is shown in FIGS. 1-6, the retractor **10** is a generally U-shaped device having a planar base **20**, a buccal shield **12**, a lingual shield **14**, and a posterior connector **16** connecting the buccal shield **12** and

the lingual shield **14**. The base **20** is defined by a pair of spaced arms **40a**, **40b**. The buccal shield **12** and the lingual shield **14** extend generally upright from the arms **40a** and **40b**.

The base **20** is contoured to grip the tooth adjacent to the tooth to be treated, and thereby, secure the retractor **10** within the patient's mouth. Once secured to the adjacent tooth, the buccal shield **12** and the lingual shield **14** of the retractor **10** protect the cheek and tongue of the patient from instruments used during a procedure. It should be understood that the retractor **10** is self-retentive. In other words, an additional force is not required to hold the retractor **10** in place while a clinician is treating tooth O. Further, while the drawings show the buccal shield **12** adjacent to the cheek C and the lingual shield **14** adjacent to the tongue T, it should be understood that positioning the retractor **10** on an opposite side of the mouth can result in the buccal shield **12** being adjacent to the tongue T and the lingual shield **14** being adjacent to the cheek C.

As shown in FIGS. 1 and 2, the arms **40a**, **40b** of the base include curved first ends **42a**, **42b**, respectively, and opposing, straight second ends **44a**, **44b**, respectively. Arm **40a** includes a generally V-shaped protrusion **45a** extending between the first and second ends **42a**, **44a** toward arm **40b**. Arm **40b** includes a generally V-shaped protrusion **45b** extending between the first and second ends **42b**, **44b** toward arm **40a**. A base clasp portion **24** is defined by an area between the first curved ends and the protrusions of both of the arms **40a**, **40b**. A base frame portion **26** is defined by an area between the protrusions and the second ends of both of the arms **40a**, **40b**. The clasp portion **24** is configured for gripping the buccal and lingual undercuts of adjacent tooth A (the tooth adjacent to the tooth to be treated). The frame portion **26** is configured to extend along opposing sides of tooth O (the tooth to be treated). The base **20** can include apertures **21a**, **21b**, for receiving pins of forceps (not shown) or other tool which can be used to place the retractor in the mouth prior to a procedure.

In an exemplary embodiment, as shown in FIGS. 2-6, the distance  $W_C$  between opposing second ends of the base is about 2.5 centimeters (FIG. 2). The distance  $W_U$  between opposing ends of the two shields **12** and **14** is about 4.0 centimeters (FIG. 4). The height  $H_S$  of each shield **12**, **14** is about 2.5 centimeters, while the height  $H_C$  of the connector is about 1.0 centimeter (FIG. 3). The height of the connector is preferably less than the height of the shields to avoid occlusal interferences between opposing teeth (FIGS. 5 and 6). It should be understood that the dimensions of the retractor **10** can vary depending on the size of the patient's teeth.

A clamp forceps can be used to place the retractor in the mouth of a patient. The pins of the clamp forceps can be inserted into apertures **20a**, **20b**. The clasp portion of the base **20** can then be positioned along buccal and lingual undercuts of the adjacent tooth A. Once the base **20** is secured to the adjacent tooth A, the forceps can be detached from the retractor.

The retractor **10** is preferably made from a resilient plastic or metal material. Preferably, the material can be sterilized in an autoclave without being distorted. The retractor parts can be rounded with smooth surfaces to avoid any possible tissue trauma.

It is to be understood that the cheek and tongue retractor for restorative and prosthodontic treatment is not limited to the specific embodiments described above, but encompasses any and all embodiments within the scope of the generic language of the following claims enabled by the embodi-

3

ments described herein, or otherwise shown in the drawings or described above in terms sufficient to enable one of ordinary skill in the art to make and use the claimed subject matter.

I claim:

1. A U-shaped cheek and tongue retractor adapted to clasp onto a tooth, consisting of:

an elongated planar base having a longitudinal axis and including a pair of spaced apart arms, each of the arms having a curved first end, a straight second end thereby defining the U-shaped retractor, and a V-shaped protrusion extending laterally between the first end and the second end thereby forming a tooth engaging clasp portion adjacent the curved first end;

a pair of upright, straight shields extending from the arms of the base and being coextensive therewith, each of the shields including a free first end and a second end,

4

wherein the distance between the free ends of the shields is 4.0 cm and the distance between the arms of the base is 2.5 cm; and

a posterior connector solely connecting the shields, wherein the connection is solely at the first end of the shields, further wherein the height of the posterior connector is 1.0 cm and the height of the shields is 2.5 cm thereby avoiding occlusal interference between opposing teeth.

2. The cheek and tongue retractor according to claim 1, wherein: each of the arms of the base include an aperture defined therethrough.

3. The cheek and tongue retractor according to claim 1, wherein the retractor is formed from a resilient material.

4. The cheek and tongue retractor according to claim 3, wherein the retractor is formed from a plastic material.

5. The cheek and tongue retractor according to claim 3, wherein the retractor is formed from a metal material.

\* \* \* \* \*