

1 - Introduction and Overview of Manufacturing

Manufacturing Processes - 2, IE-352

Ahmed M El-Sherbeeny, PhD

Fall-2013

INTRODUCTION AND OVERVIEW OF MANUFACTURING

- 
1. What is Manufacturing?
 2. Materials in Manufacturing
 3. Manufacturing Processes
 4. Production Systems



1- What is manufacturing?

“act of making something (a product) from raw materials”



Manufacturing is Important

- Technologically
- Economically
- Historically

Manufacturing - Technologically Important

What is technology?

Technology - the application of science to provide society and its members with those things that are needed or desired

Technology provides the products that help our society and its members live better

What do these products have in common?

They are all manufactured

Manufacturing is the essential factor that makes technology possible



Manufacturing - Economically Important



Manufacturing is one way by which nations create material wealth

U.S. economy:

<u>Sector</u>	<u>% of GNP*</u>
Manufacturing	20%
Agriculture, minerals, etc.	5%
Construction & utilities	5%
Service sector – retail, transportation, banking, communication, education, and government	70%

* GNP= Gross Net Product



What is Manufacturing?

The word *manufacture* is derived from two Latin words *manus* (hand) and *factus* (make); the combination means “made by hand”

- Most modern manufacturing operations are accomplished by mechanized and automated equipment that is supervised by human workers

Manufacturing - Technologically

Application of physical and chemical processes to alter the geometry, properties, and/or appearance of a starting material to make parts or products

- Manufacturing also includes assembly
- Almost always carried out as a sequence of operations

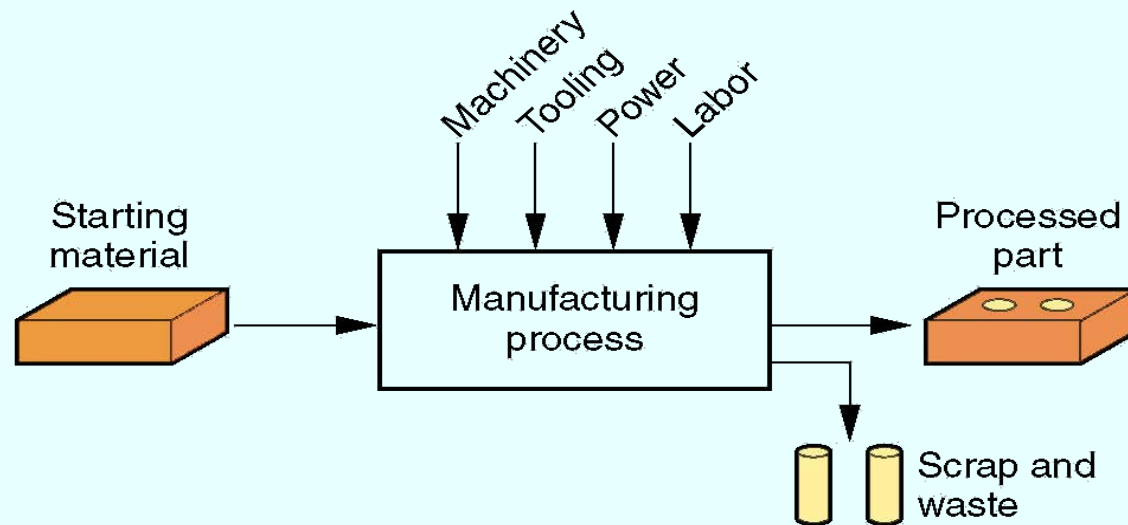

(a)

Figure 1.1 (a)
Manufacturing
as a technical
process

Manufacturing - Economically

Manufacturing *adds value* to the material by changing its shape or properties, or by combining it with other materials (this is done by means of one or more processing and/or assembly operations)

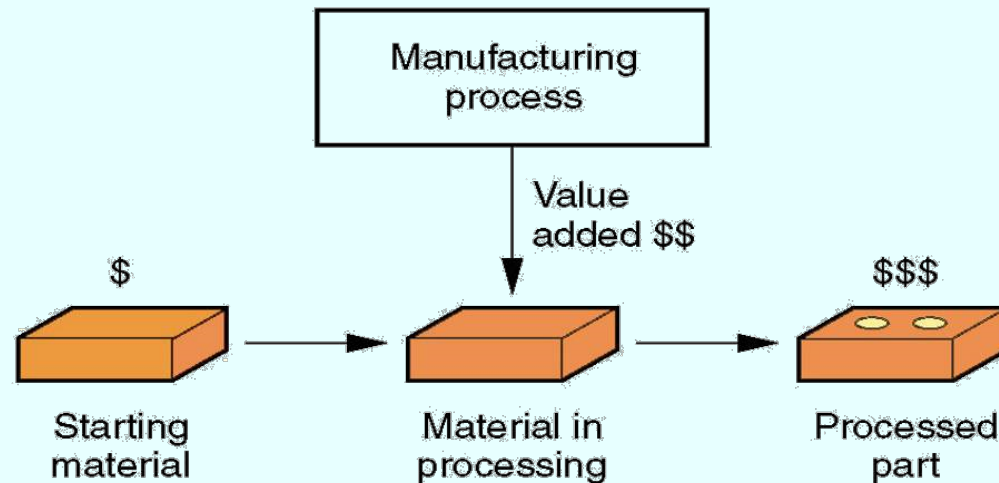

Figure 1.1 (b)
Manufacturing
as an economic
process

(b)



Manufacturing Industries

Industry consists of enterprises and organizations that produce or supply goods and services

Industries can be classified as:

Primary industries - those that cultivate and exploit natural resources, e.g., **farming, mining**

Secondary industries - take the outputs of primary industries and convert them into consumer and capital goods - **manufacturing** is the principal activity, other examples: **construction**, and **electric power generation**

Tertiary industries - service sector, e.g. banking

Manufacturing Industries - continued

- Manufacturing includes several industries whose products are not covered in this book; e.g., apparel, beverages, chemicals, and food processing
- For our purposes, **manufacturing** means **production of hardware**
 - Nuts and bolts, forgings, cars, airplanes, digital computers, plastic parts, and ceramic products





Production Quantity Q

The **quantity of products Q** made by a factory has an important influence on the way its people, facilities, and procedures are organized

- Annual production quantities can be classified into three ranges:

Production range

Low production

Medium production

High production

Annual Quantity Q

1 to 100 units

100 to 10,000 units

10,000 to millions

Product Variety P

Product variety P refers to different product types or models produced in the plant.

- Different products have different features
 - They are intended for different markets
 - Some have more parts than others
- When the number of product types made in the factory is high, this indicates high product variety



P versus Q in Factory Operations

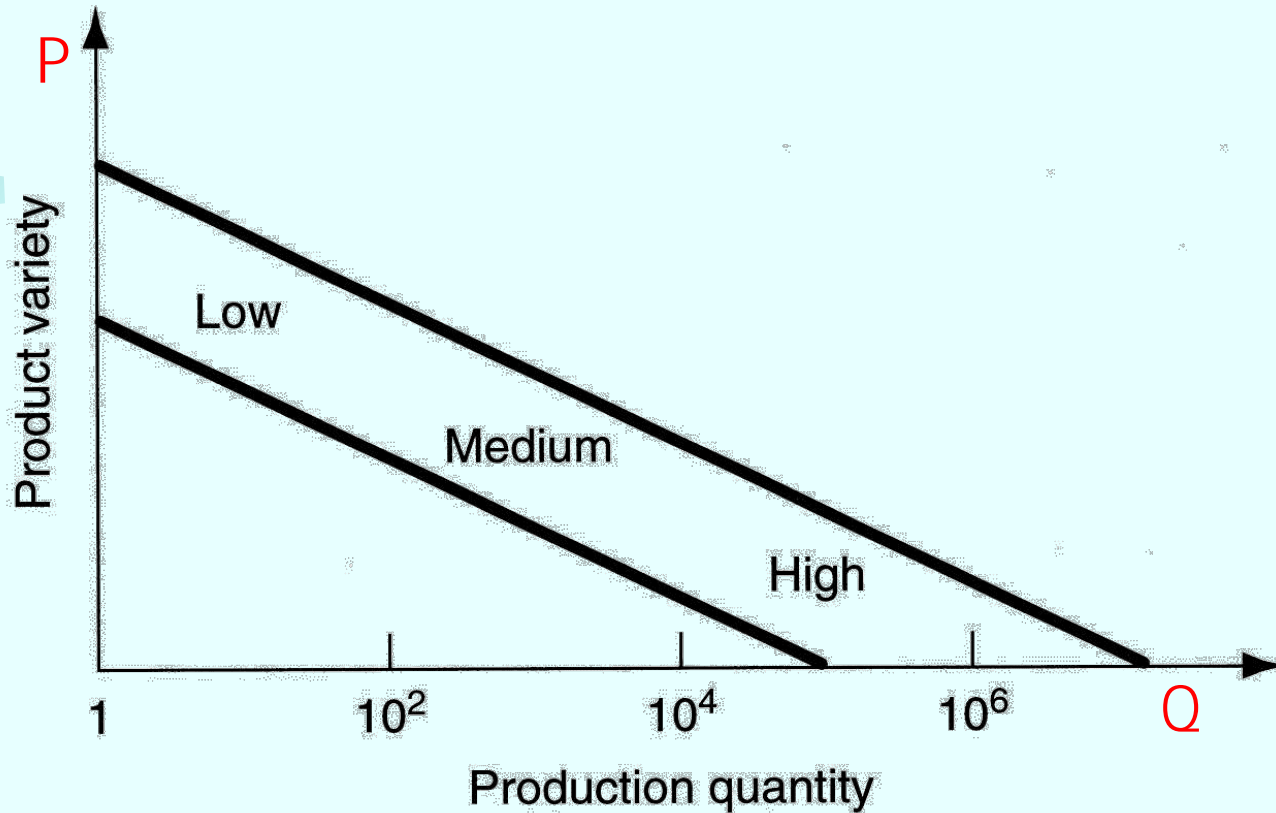

Figure 1.2 P-Q Relationship

More About Product Variety

Although P is a quantitative parameter, it is much less exact than Q because details on how much the designs differ is not captured simply by the number of different designs



- *Soft product variety* - small differences between products, e.g., between car models made on the same production line, with many common parts among models



- *Hard product variety* - products differ substantially, e.g., between a small car and a large truck, with few common parts (if any)



Manufacturing Capability

A manufacturing plant consists of *processes* and *systems* (and people, of course) designed to transform a certain limited range of *materials* into *products* of increased value.

- The three building blocks - *materials*, *processes*, and *systems* - are the subject of modern manufacturing.



Manufacturing capability includes:

1. Technological processing capability
2. Physical product limitations
3. Production capacity

1. Technological Processing Capability

The available set of manufacturing processes in the plant (or company)

- Certain manufacturing processes are suited to certain materials
(By specializing in certain processes, the plant is also specializing in certain materials)
- Includes not only the physical processes, but also the expertise of the plant personnel

Examples:

A machine shop cannot roll steel

A steel mill cannot build cars





2. Physical Product Limitations

Given a plant with a certain set of processes, there are **size and weight limitations** on the parts or products that can be made in the plant

- Product size and weight affect:
 - Production equipment
 - Material handling equipment



3. Production Capacity (or plant capacity)

Defined as the **maximum quantity** that a plant can produce in a given time period (e.g., month or year) **under assumed operating conditions**

Operating conditions refer to number of shifts per week, hours per shift, direct labor manning levels in the plant, and so on

Capacity is measured in terms of **output units**, such as tons of steel or number of cars produced by the plant

The background features a light blue gradient with several semi-transparent gear shapes of varying sizes and shades of gray. On the left side, there is a vertical strip with a colorful, abstract, and textured pattern in shades of orange, red, purple, and blue.

2- Materials in Manufacturing



Materials in Manufacturing

Most engineering materials can be classified into one of three basic categories:

1. **Metals**
2. **Ceramics**
3. **Polymers**

Their **chemistries** and also their **mechanical and physical properties** are different

- These differences affect the manufacturing processes that can be used to produce products from them



1. Metals

Usually *alloys*, which are composed of two or more elements, at least one of which is metallic

Two basic groups:

Ferrous metals - based on iron, comprises about 75% of metal tonnage in the world:

Steel = Fe-C alloy (0.02 to 2.11% C)

Cast iron = Fe-C alloy (2% to 4% C)

Nonferrous metals - all other metallic elements and their alloys: aluminum, copper, magnesium, nickel, silver, tin, titanium, etc.

2. Ceramics

Compounds containing metallic (or semi-metallic) and nonmetallic elements.



Typical nonmetallic elements are oxygen, nitrogen, and carbon

- For processing, ceramics divide into:
 1. **Crystalline ceramics** – includes:
 - Traditional ceramics, such as clay (hydrous aluminum silicates)
 - Modern ceramics, such as alumina (Al_2O_3)
 2. **Glasses** – mostly based on silica (SiO_2)

3. Polymers

Compound formed of repeating structural units called *mers*, whose atoms share electrons to form very large molecules

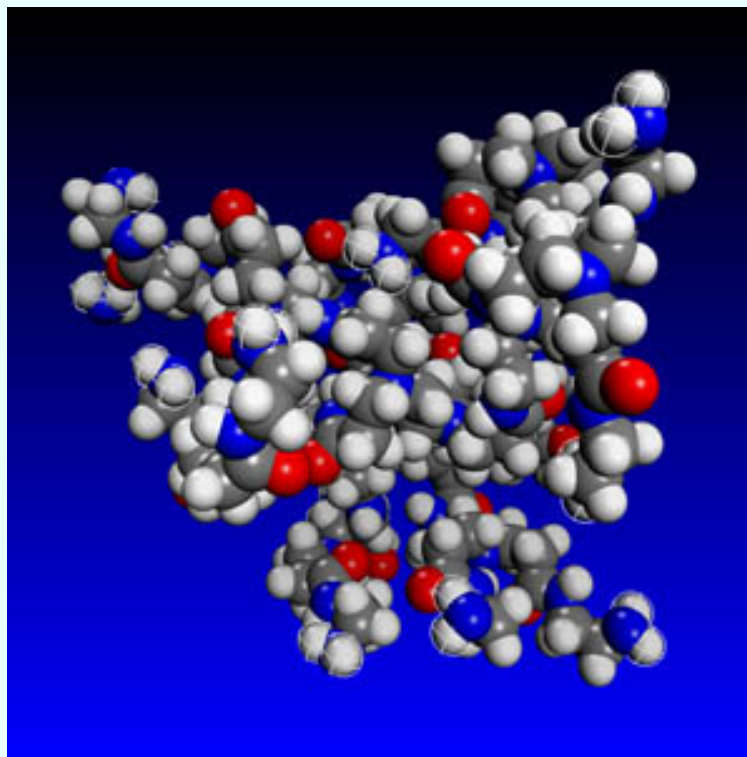

3- Polymers

Three categories:

1. **Thermoplastic polymers** - can be subjected to multiple heating and cooling cycles without altering molecular structure
2. **Thermosetting polymers** - molecules chemically transform (cure) into a rigid structure – cannot be reheated
3. **Elastomers** - shows significant elastic behavior

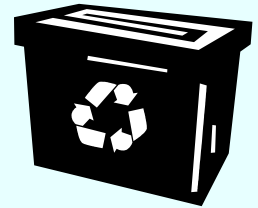

In addition- Composites

Nonhomogeneous mixtures of the other three basic types rather than a unique category

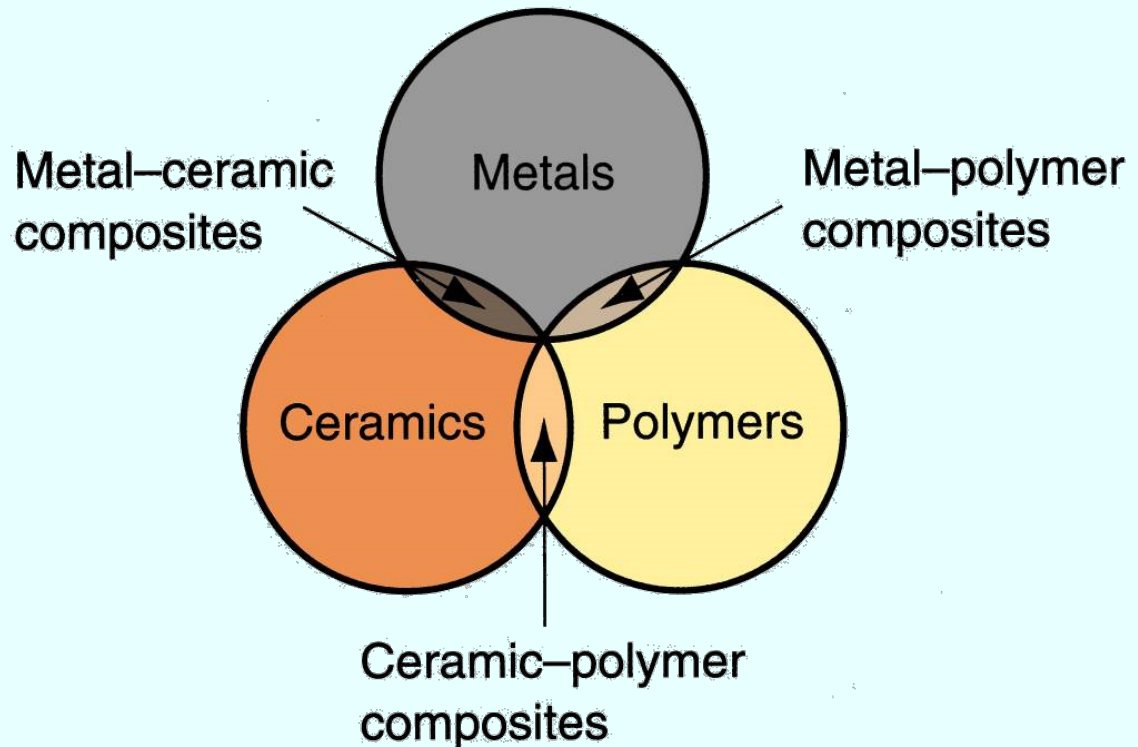
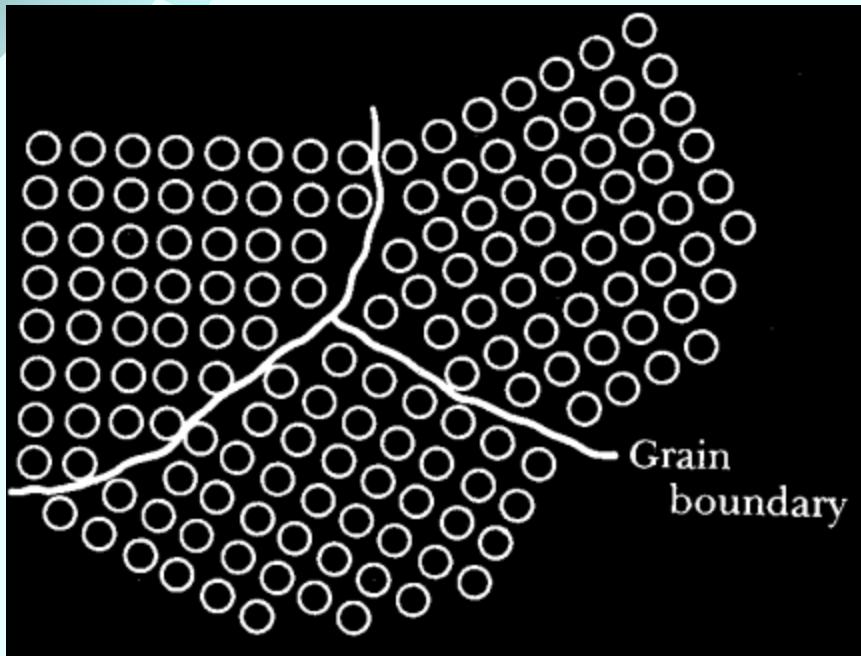

Figure 1.3 Venn diagram of three basic material types plus composites

Composites

Material consisting of two or more phases that are processed separately and then bonded together to achieve properties superior to its constituents



Phase - homogeneous mass of material, such as grains of identical unit cell structure in a solid metal

Usual structure consists of **particles or fibers** of one phase mixed in a second phase

Properties depend on components, physical shapes of components, and the way they are combined to form the final material

Composites

Future Promise of Smart Materials and Structure



The background of the slide is a light cyan color with several large, semi-transparent gear shapes scattered across it. On the left side, there is a vertical strip with a colorful, abstract pattern of gears in various colors like red, orange, purple, and blue. The main title is centered in a dark blue font.

3- Manufacturing Processes

Manufacturing Processes

Two basic types:

1. **Processing operations** - transform a work material from one state of completion to a more advanced state
 - Operations that change the geometry, properties, or appearance of the starting material
2. **Assembly operations** - join two or more components to create a new entity



Figure 1.4 Classification of manufacturing processes

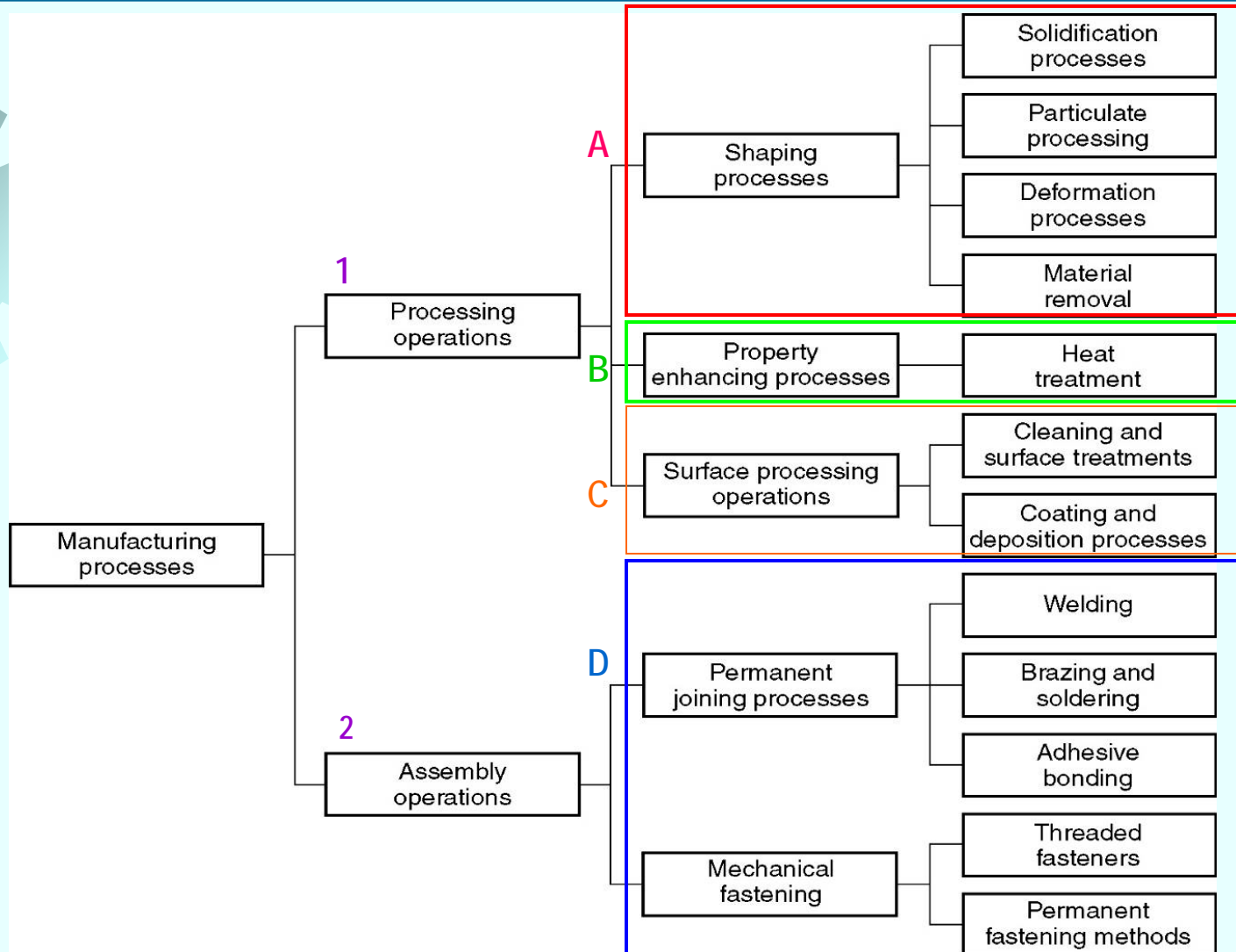

Processing Operations



Click to see figure 1-4 again

Alters a material's shape, physical properties, or appearance in order to add value

■ Three categories of processing operations:

1. **Shaping operations** - alter the geometry of the starting work material
2. **Property-enhancing operations** - improve physical properties without changing shape
3. **Surface processing operations** - to clean, treat, coat, or deposit material on exterior surface of the work

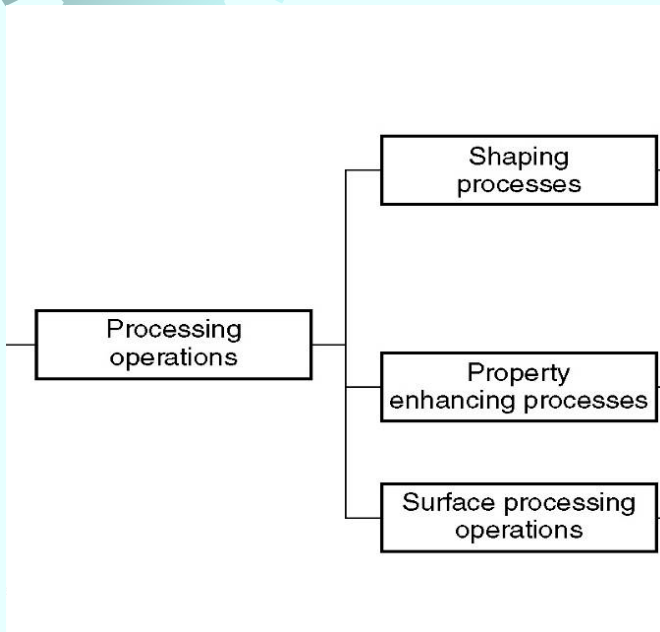



A

Shaping Processes – Four Categories

1. **Solidification processes** - starting material is a heated **liquid or semifluid**
2. **Particulate processing** - starting material consists of **powders**
3. **Deformation processes** - starting material is a **ductile solid** (commonly metal)
4. **Material removal processes** - starting material is a **ductile or brittle solid**

A

1- Solidification Processes

Starting material is heated sufficiently to transform it into a liquid or highly plastic state

- Examples: metal casting, plastic molding

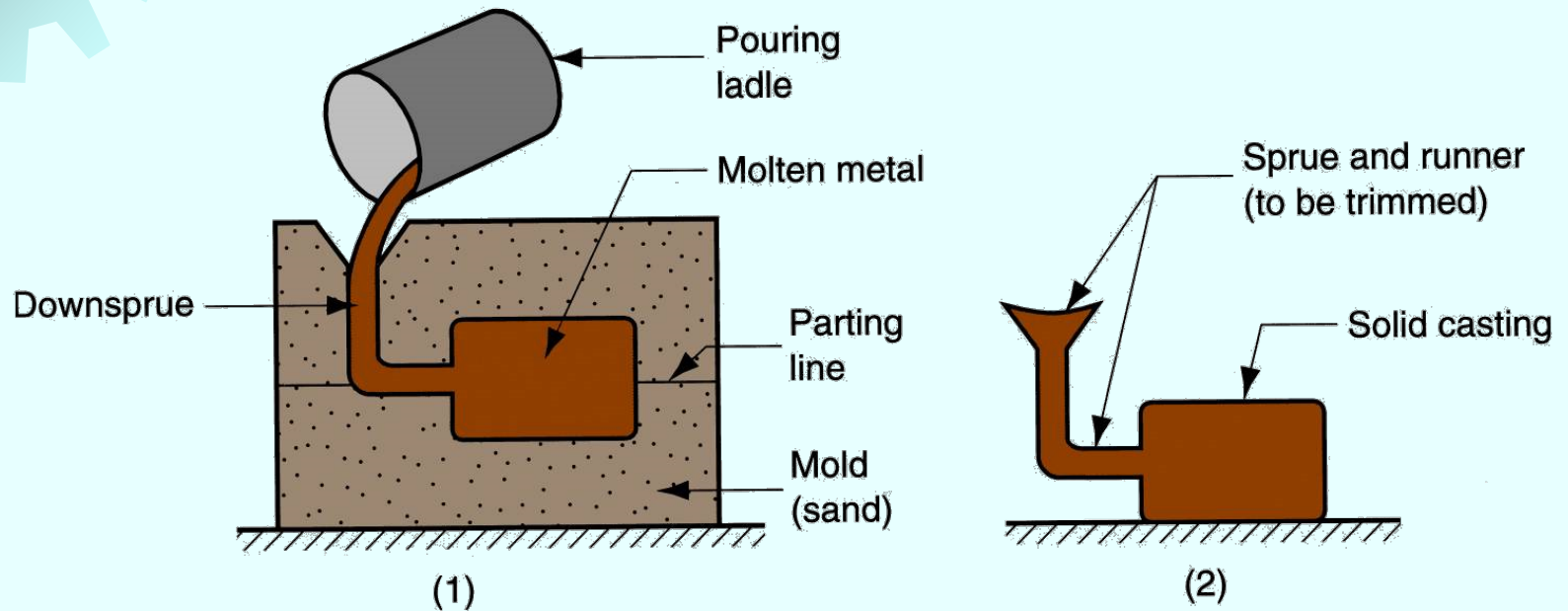

A

2- Particulate Processing

Starting materials are powders of metals or ceramics

- Usually involves pressing and sintering, in which powders are first compressed and then heated to bond the individual particles

Steps: Pressing and sintering

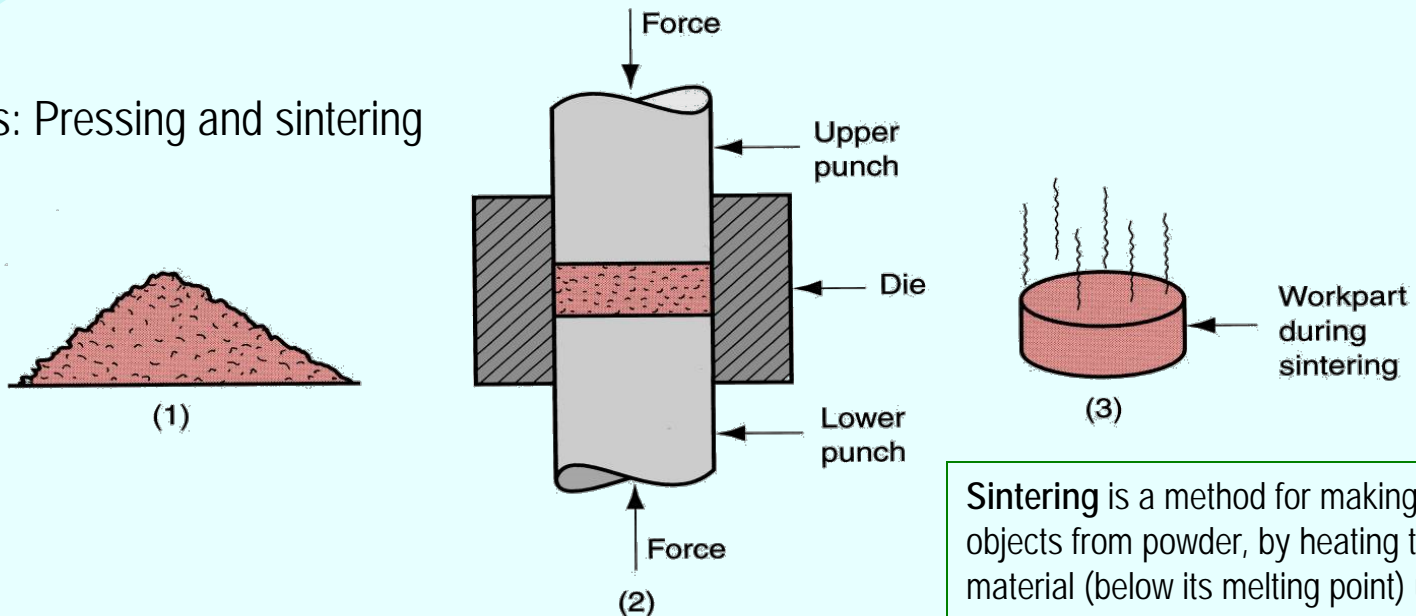

Sintering is a method for making objects from powder, by heating the material (below its melting point) until its particles adhere to each other.

A

3- Deformation Processes

Starting workpart is shaped by application of forces that exceed the yield strength of the material

- Examples: (a) forging, (b) extrusion

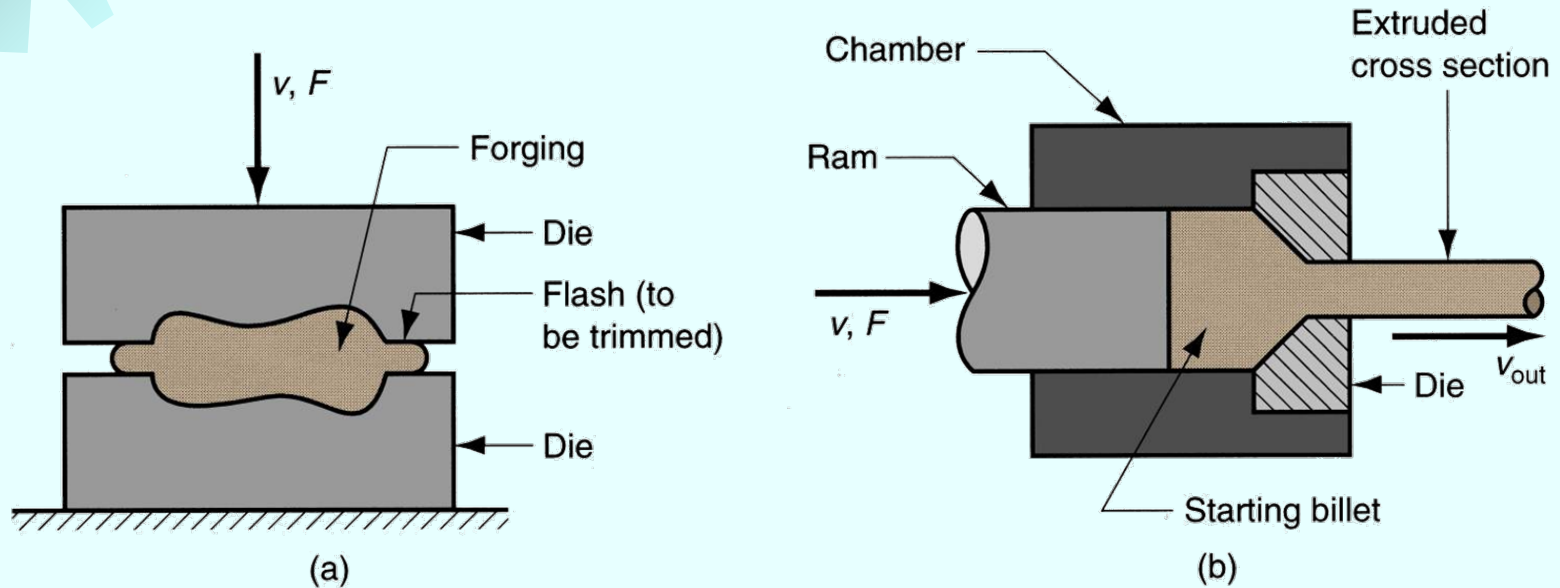

A press machine performs extrusion.

A

4- Material Removal Processes

Excess material removed from the starting piece so what remains is the desired geometry

- Examples: machining such as turning, drilling, and milling; also grinding and nontraditional processes

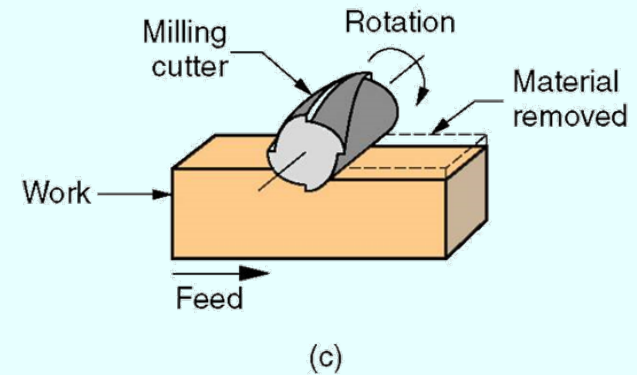
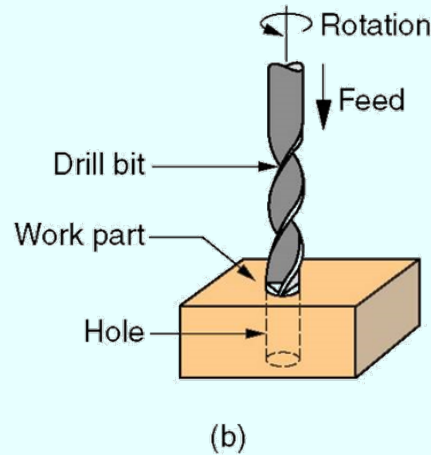
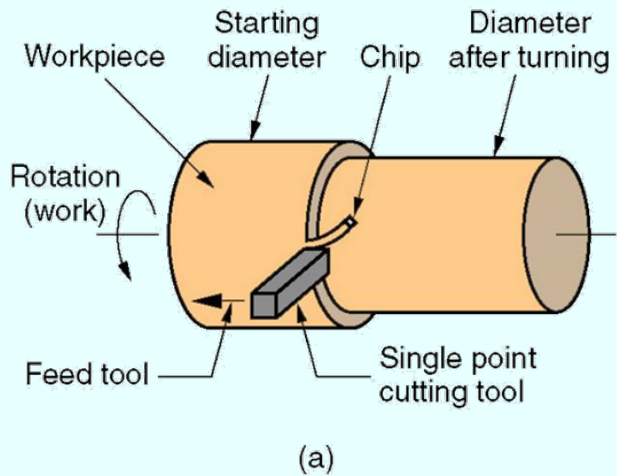

A

Waste in Shaping Processes

Desirable to minimize waste in part shaping

- Material removal processes are wasteful in unit operations, simply by the way they work
- Most casting, molding, and particulate processing operations waste little material
- Terminology for minimum waste processes:
 - *Net shape processes* - when most of the starting material is used and no subsequent machining is required
 - *Near net shape processes* - when minimum amount of machining is required



Click to see figure 1-4 again

B

Property-Enhancing Processes

Performed to improve mechanical or physical properties of work material

- Part shape is not altered, except unintentionally
 - Example: unintentional warping of a heat treated part

- Examples:
 - Heat treatment of metals and glasses
 - Sintering of powdered metals and ceramics



Click to see figure 1-4 again

Surface Processing Operations

- **Cleaning** - chemical and mechanical processes to remove dirt, oil, and other contaminants from the surface
- **Surface treatments** - mechanical working such as sand blasting, and physical processes like diffusion
- **Coating and thin film deposition** - coating exterior surface of the workpart



Click to see figure 1-4 again

Assembly Operations

Two or more separate parts are joined to form a new entity

■ Types of assembly operations:

1. **Joining processes** – create a permanent joint

- Welding, brazing, soldering, and adhesive bonding

2. **Mechanical assembly** – fastening by mechanical methods

- Threaded fasteners (screws, bolts and nuts); press fitting, expansion fits

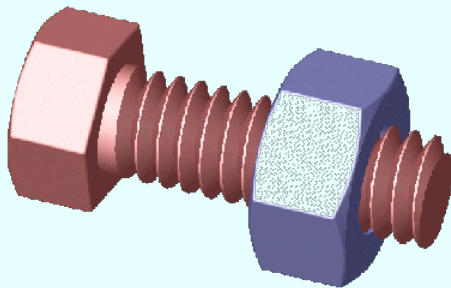

The background features a light blue gradient with several semi-transparent gear shapes of varying sizes and shades of gray. On the left side, there is a vertical strip with a colorful, abstract pattern of overlapping gear shapes in shades of red, orange, yellow, and purple.

Production Systems



Production Systems

People, equipment, and procedures used for the combination of materials and processes that constitute a firm's manufacturing operations

- A manufacturing firm must have systems and procedures to efficiently accomplish its type of production

Two categories of production systems:

1. Production facilities
2. Manufacturing support systems

Both categories include people (people make the systems work)

Production systems

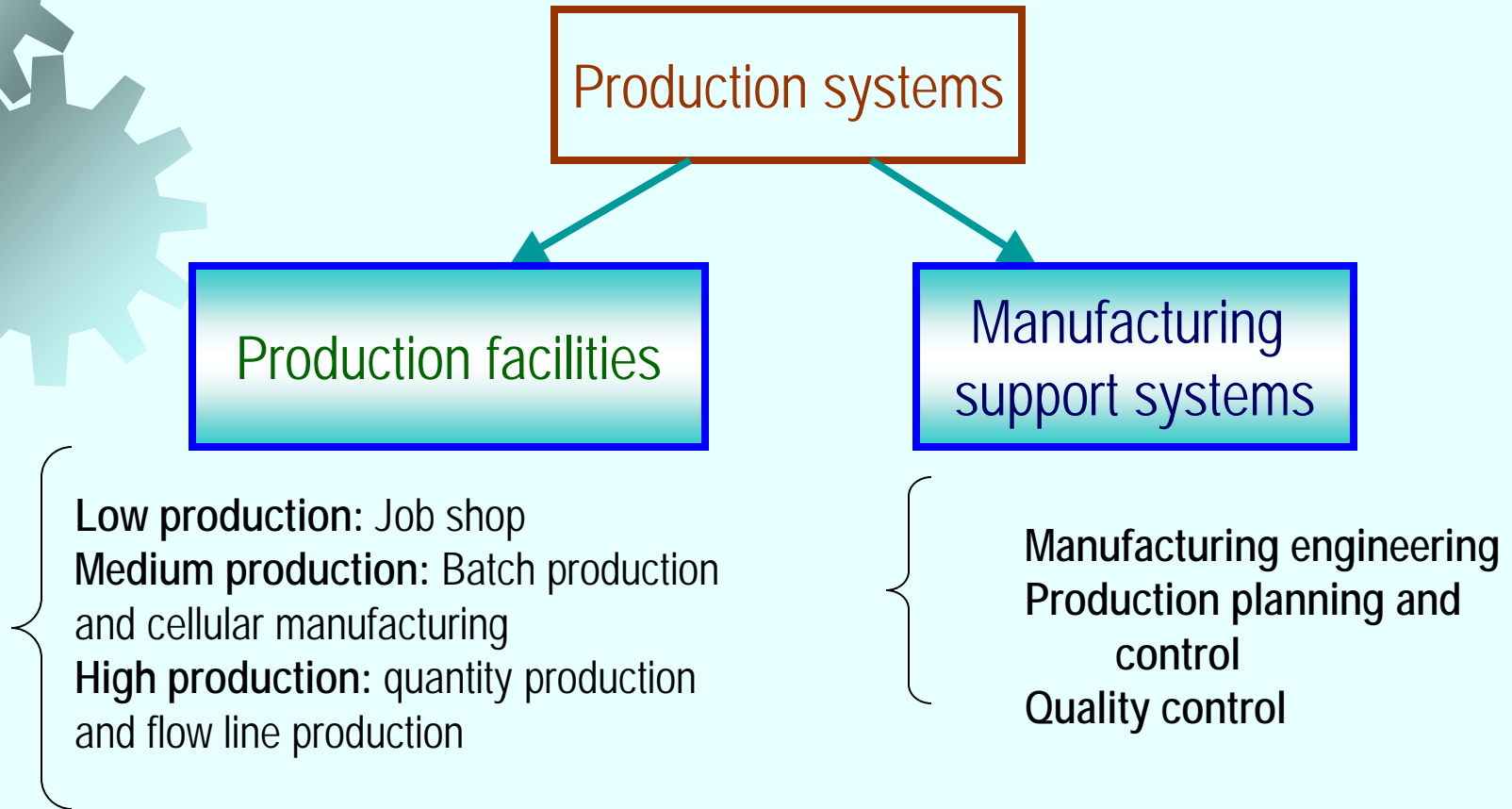



1- Production Facilities

The factory, production equipment, and material handling systems

- Production facilities "touch" the product
- Includes the way the equipment is arranged in the factory - the plant layout

Equipment usually organized into logical groupings, called *manufacturing systems*

Examples:

Automated production line

Machine cell consisting of an industrial robot and two machine tools



Facilities versus Product Quantities

A company designs its manufacturing systems and organizes its factories to serve the particular mission of each plant

- Certain types of production facilities are recognized as the most appropriate for a given type of manufacturing:
 1. Low production – 1 to 100
 2. Medium production – 100 to 10,000
 3. High production – 10,000 to >1,000,000
- Different facilities are required for each of the three quantity ranges

Low Production

Job shop is the term used for this type of production facility

- A job shop makes low quantities of specialized and customized products
 - Products are typically complex, e.g., space capsules, prototype aircraft, special machinery



- Equipment in a job shop is general purpose
- Labor force is highly skilled
- Designed for maximum flexibility

Medium Production

Two different types of facilities, depending on product variety:

Batch production

- Suited to hard product variety
- Setups required between batches



Cellular manufacturing

- Suited to soft product variety
- Worker cells organized to process parts without setups between different part styles





High Production

- Often referred to as *mass production*
 - High demand for product
 - Manufacturing system dedicated to the production of that product

- Two categories of mass production:
 1. **Quantity production**
 2. **Flow line production**



Quantity Production

Mass production of single parts on single machine or small numbers of machines

- Typically involves standard machines equipped with special tooling
- Equipment is dedicated full-time to the production of one part or product type
- Typical layouts used in quantity production are process layout and cellular layout



Flow Line Production

Multiple machines or workstations arranged in sequence, e.g., production lines

- Product is complex
 - Requires multiple processing and/or assembly operations
- Work units are physically moved through the sequence to complete the product
- Workstations and equipment are designed specifically for the product to maximize efficiency

2- Manufacturing Support Systems

A company must organize itself

- to design the processes and equipment,
- plan and control production, and
- satisfy product quality requirements

Accomplished by manufacturing support systems - people and procedures by which a company manages its production operations

Typical departments:

1. Manufacturing engineering
2. Production planning and control
3. Quality control

Overview of Major Topics

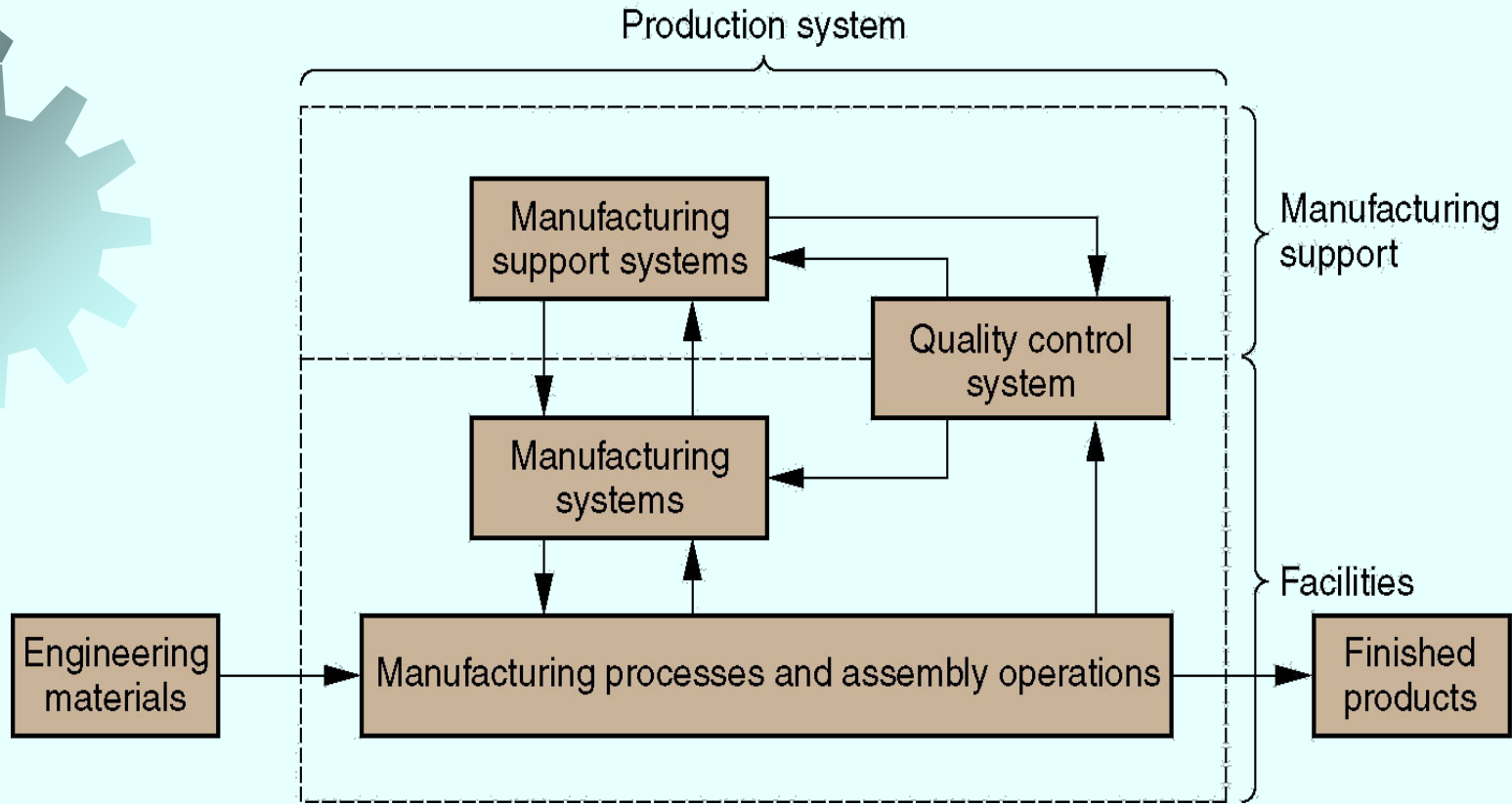

Figure 1.10 Overview of production system and major topics in *Fundamentals of Modern Manufacturing*.

A spectacular scene in steelmaking is charging of a basic oxygen furnace, in which molten pig iron produced in a blast furnace is poured into the BOF (Basic Oxygen Furnace). Temperatures are around 1650°C (3000 ° F).



A machining cell consisting of two horizontal machining centers supplied by an in-line pallet shuttle (photo courtesy of Cincinnati Milacron).





A robotic arm performs unloading and loading operation in a turning center using a dual gripper (photo courtesy of Cincinnati Milacron).





Metal chips fly in a high speed turning operation performed on a computer numerical control turning center (photo courtesy of Cincinnati Milacron).

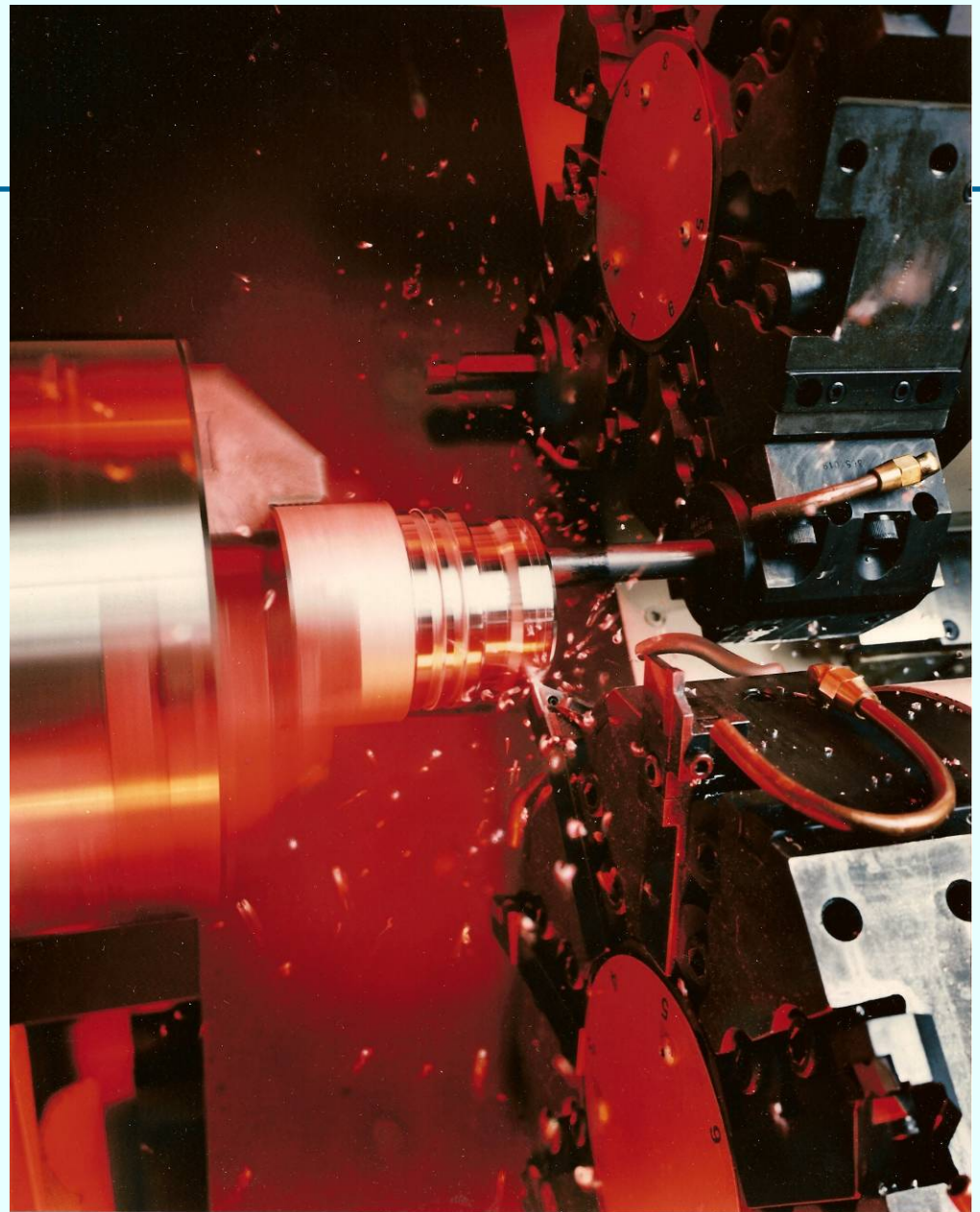

Photomicrograph of the cross section of multiple coatings of titanium nitride and aluminum oxide on a cemented carbide substrate (photo courtesy of Kennametal Inc.).

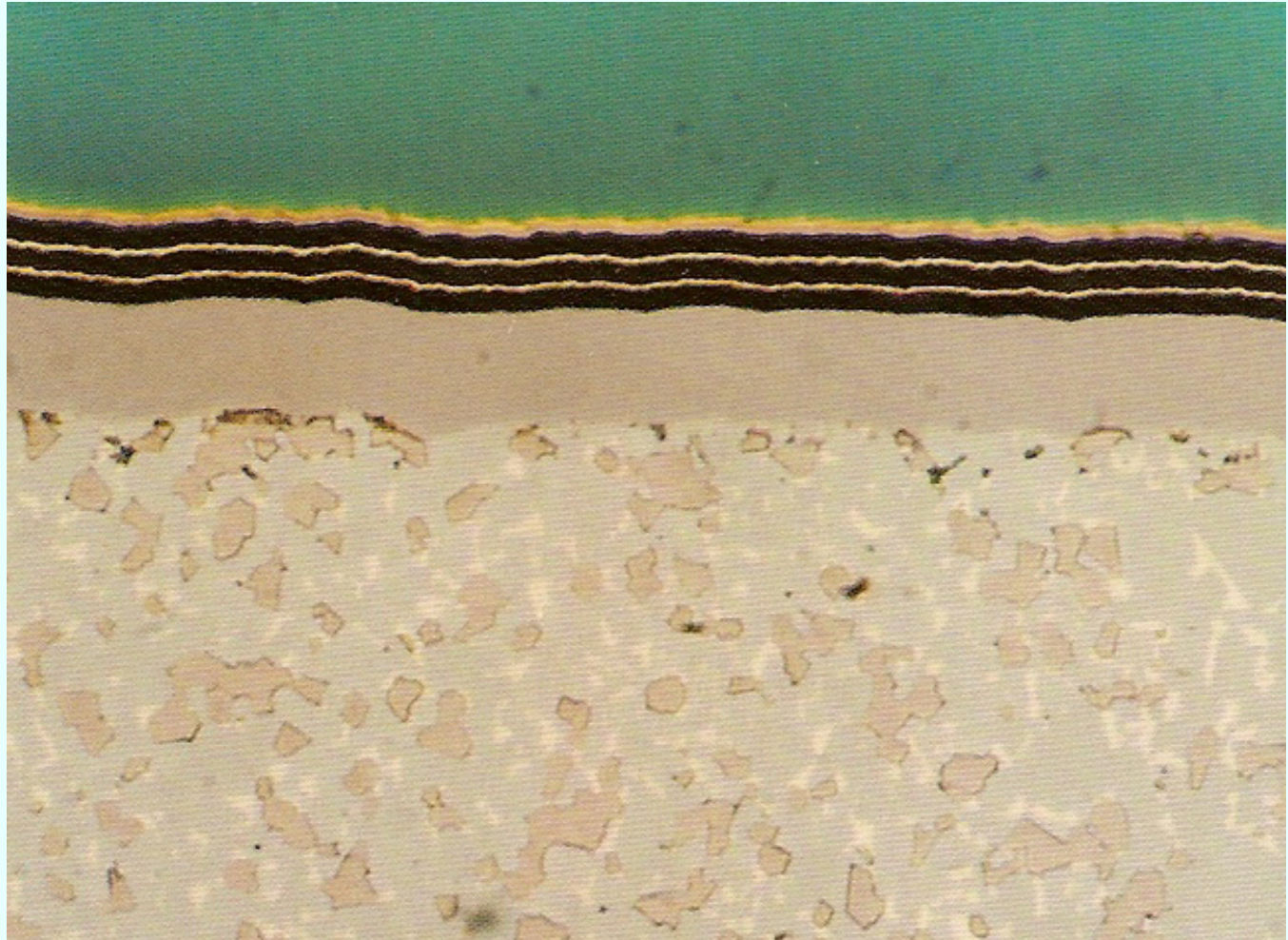

A batch of silicon wafers enters a furnace heated to 1000°C (1800°F) during fabrication of integrated circuits under clean room conditions (photo courtesy of Intel Corporation).





Two welders perform arc welding on a large steel pipe section (photo courtesy of Lincoln Electric Company).





Automated dispensing of adhesive onto component parts prior to assembly
(photo courtesy of EFD, Inc.).

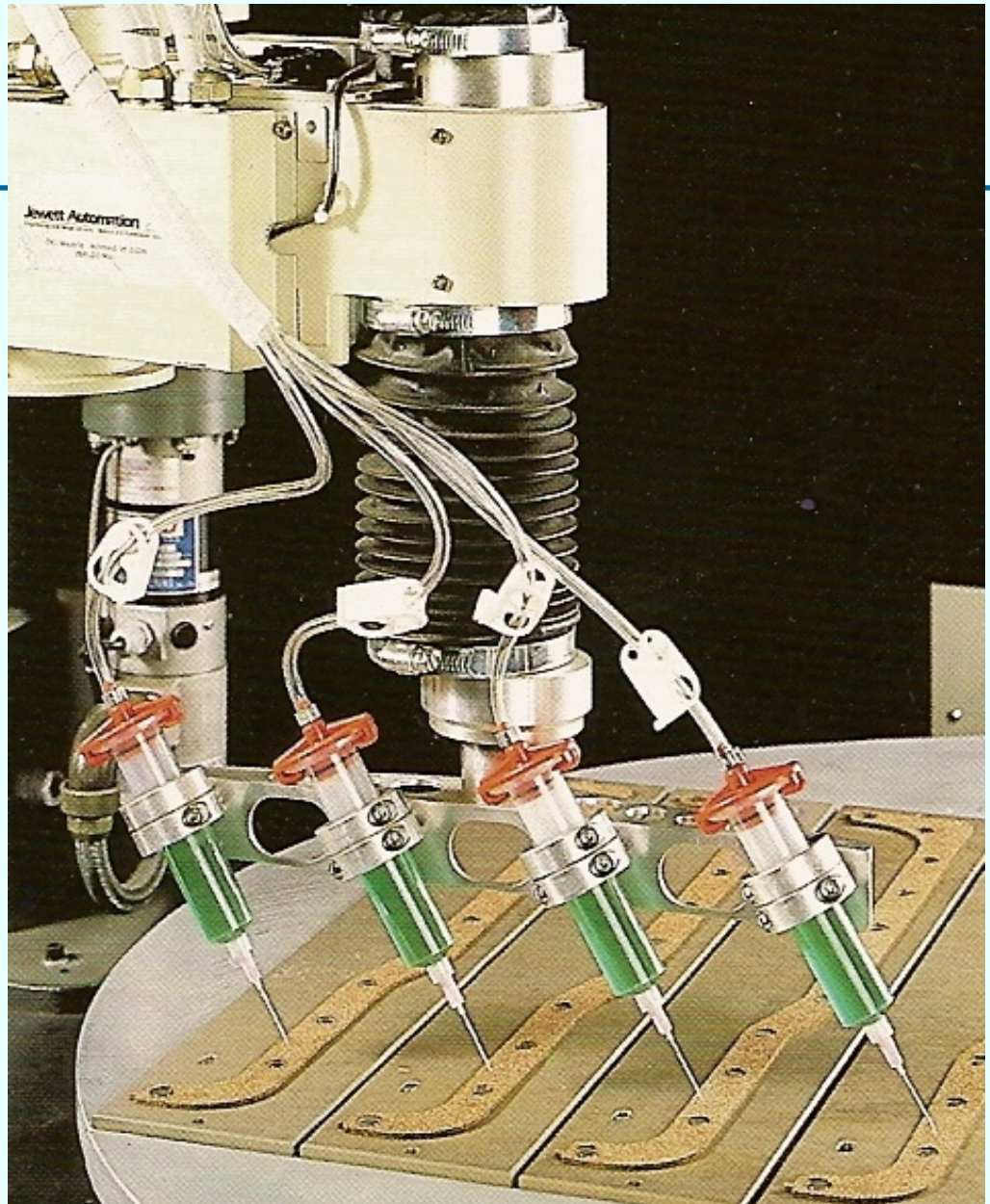



Assembly workers on an engine assembly line (photo courtesy of Ford Motor Company).

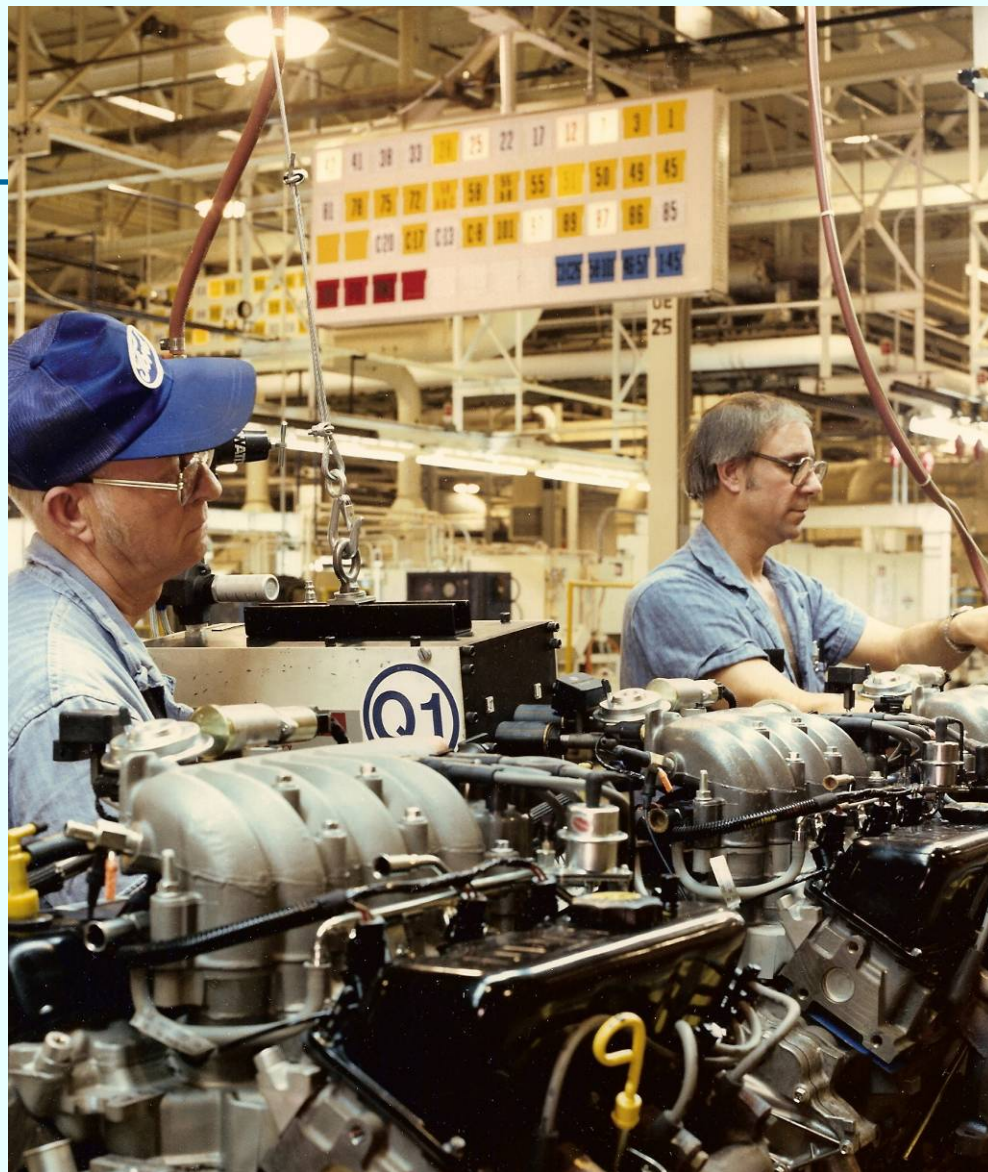



Assembly operations on the Boeing 777

(photo courtesy of Boeing
Commercial Airplane Co.).

