

PHC 541
Chromatographic and Bioanalytical Analysis

Dr. Motiur Rahman
Associate Professor
Pharmaceutical Chemistry
College of Pharmacy
King Saud University
Riyadh, Saudi Arabia

PHC 541	Chromatographic and Bioanalytical Analysis	4 (3+2)
<p>This course explores in details the practical aspects necessary to conduct a successful bioanalytical assay. The course discusses in details topics related to hyphenated techniques, in particular LC-MS, and explores the technologies and method development involved in the process. The course also discusses other hyphenated techniques such as GC-MS, CE-MS, as well as immunoassay.</p>		

1st Day

Liquid Chromatography–Mass Spectrometry (LC-MS)

- ❑ *Combines the physical separation capabilities of liquid chromatography (or HPLC) with the mass analysis capabilities of mass spectrometry (MS).*
- ❑ *Liquid chromatography separates mixtures with multiple components,*
- ❑ *Mass spectrometry provides structural identity of the individual components with high molecular specificity detection sensitivity.*
- ❑ *Can be used to analyze biochemical, organic, and inorganic compounds commonly found in complex samples of environmental and biological origin.*
- ❑ *LC-MS may be applied in a wide range of sectors including*
 - ❖ *Biotechnology,*
 - ❖ *Environment monitoring,*
 - ❖ *Food processing, and*
 - ❖ *Pharmaceutical,*
 - ❖ *Agrochemical,*
 - ❖ *and Cosmetic industries.*

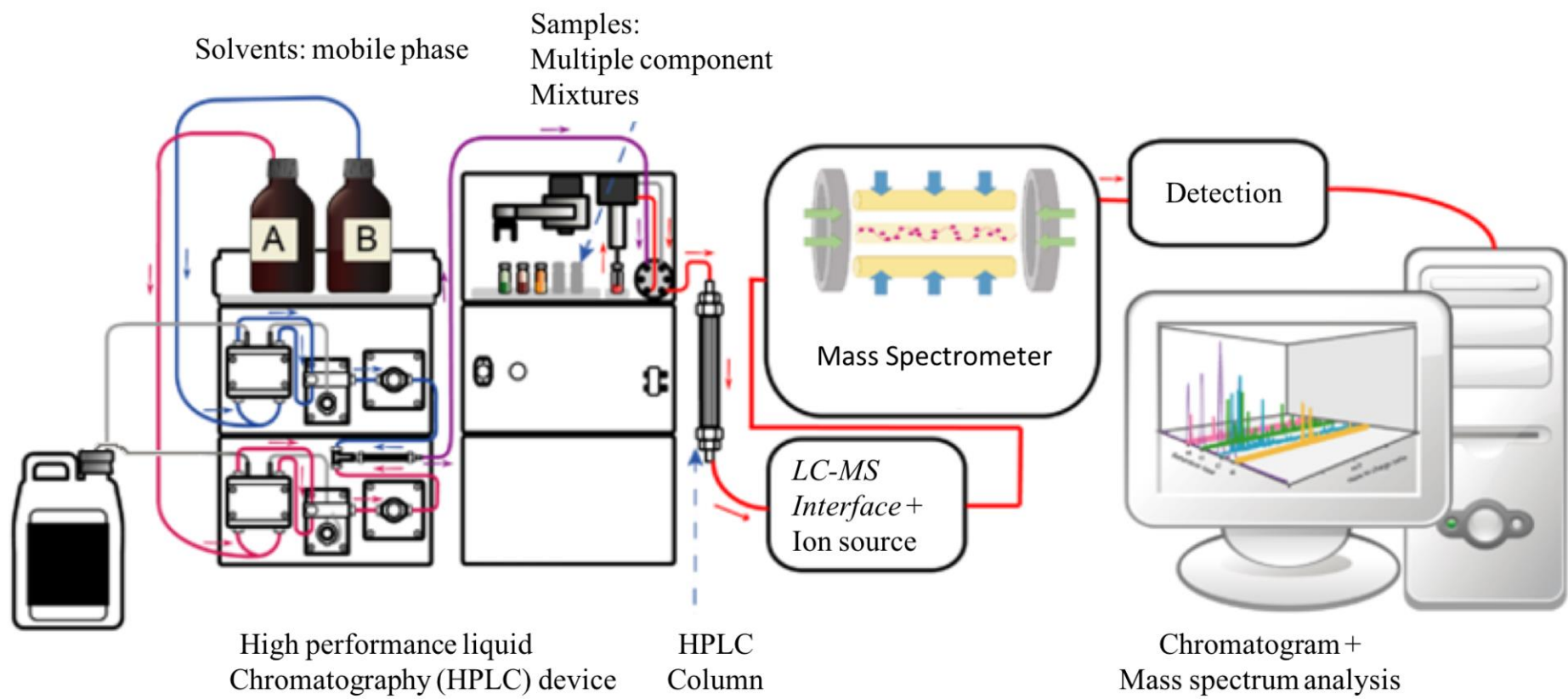

Gas Chromatography–Mass Spectrometry (GC-MS)

- A GC-MS instrument is composed of following two major building blocks:
 - i. a gas chromatograph and
 - ii. a mass spectrometer.
- GC-MS separates chemical mixtures into individual components (using a gas chromatograph) and identifies / quantifies the components at a molecular level (using a MS detector).
- It is one of the most accurate and efficient tools for analyzing volatile organic samples.

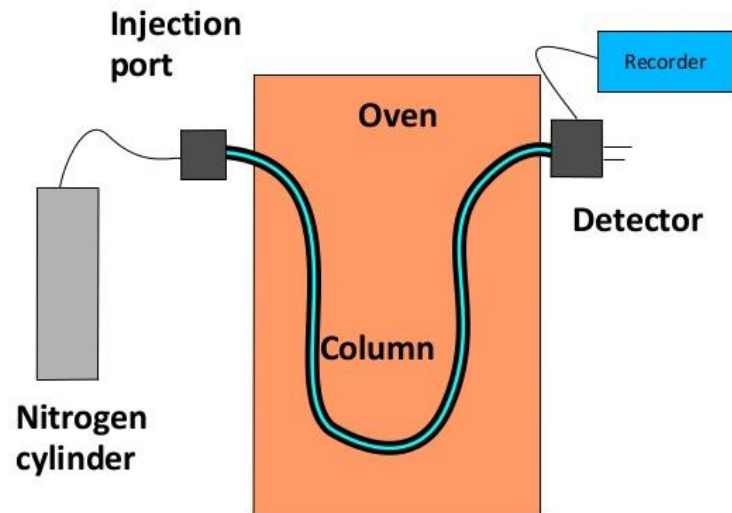

Capillary Electrophoresis–Mass Spectrometry (CE-MS)

- ❑ *Combination of the liquid separation process of capillary electrophoresis with mass spectrometry.*
- ❑ *Provide high separation efficiency*
- ❑ *Provide molecular mass information in a single analysis.*
- ❑ *It has high resolving power and sensitivity,*
- ❑ *Requires minimal volume*
- ❑ *Can analyze at high speed*
- ❑ *Ions are typically formed by electrospray ionization*
- ❑ *Ions also be formed by matrix-assisted laser desorption/ionization other ionization techniques.*
- ❑ *Applications*
- ❑ *Proteomics*
- ❑ *Quantitative analysis of biomolecules*
- ❑ *Clinical medicine*
- ❑ *Protein and peptides analysis and other biomolecules.*

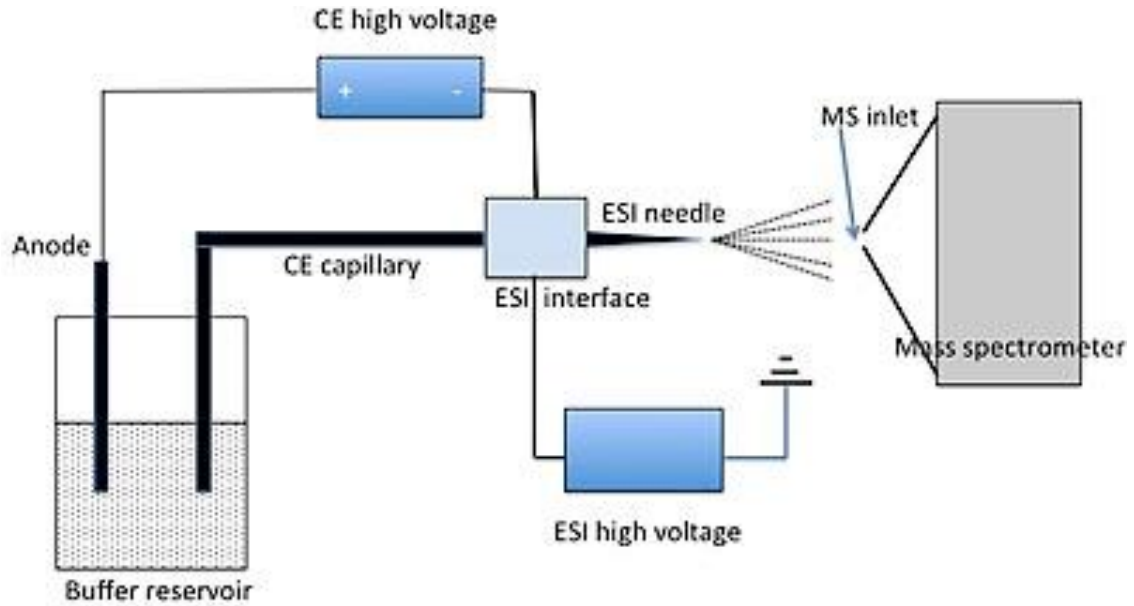
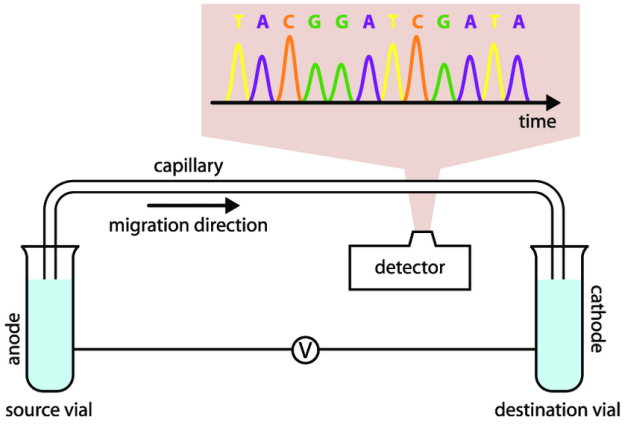

Hyphenated Techniques

- A Hyphenated technique is combination or **coupling of two different analytical techniques** with the help of proper interface.
- Hirschfield (1980) introduced the term "hyphenation" to refer to the on-line combination of a separation technique and one or more spectroscopic detection techniques.
- **Chromatography** - Produces pure or nearly pure fractions of chemical components in a mixture. Spectroscopy – Produces selective information for identification using standards or library spectra.
- The hyphenated technique is developed from the coupling of a separation technique and an online spectroscopic detection technology.
- The number of existing techniques has been combined to expand the utility.
- The direct conjugation of chromatographic technique with spectroscopic examination of separated fraction constitutes several powerful analytical techniques.

Hyphenated Techniques

- The hyphenation does not always have to be between two techniques; the coupling of separation or detection techniques
- Recently, more than two techniques coupled together to form a more powerful integrated system have revolutionized the trace element analysis industry.
- Also called double hybrid e.g. LC-PDA-MS; LC-MS-MS; LC-NMR-MS instruments have become available and have been applied to pharmaceutical problem solving.
- Online coupling with solid phase extraction (SPE), solid phase micro extraction or large volume injection can be incorporated to build in a more powerful integrated system e.g. SPE-LC-MS.

- ❖ Liquid chromatography-photodiode-array-mass spectrometry (**LC-PDA-MS**)
- ❖ Solid phase extraction-Liquid chromatography-mass spectrometry (**SPE-LC-MS**)
- ❖ large-volume injection-Liquid chromatography-mass spectrometry (**LVI-LC-MS**)

Hyphenated Techniques

combination of-

1. separation-separation,
2. separation-identification &
3. Identification-identification techniques.

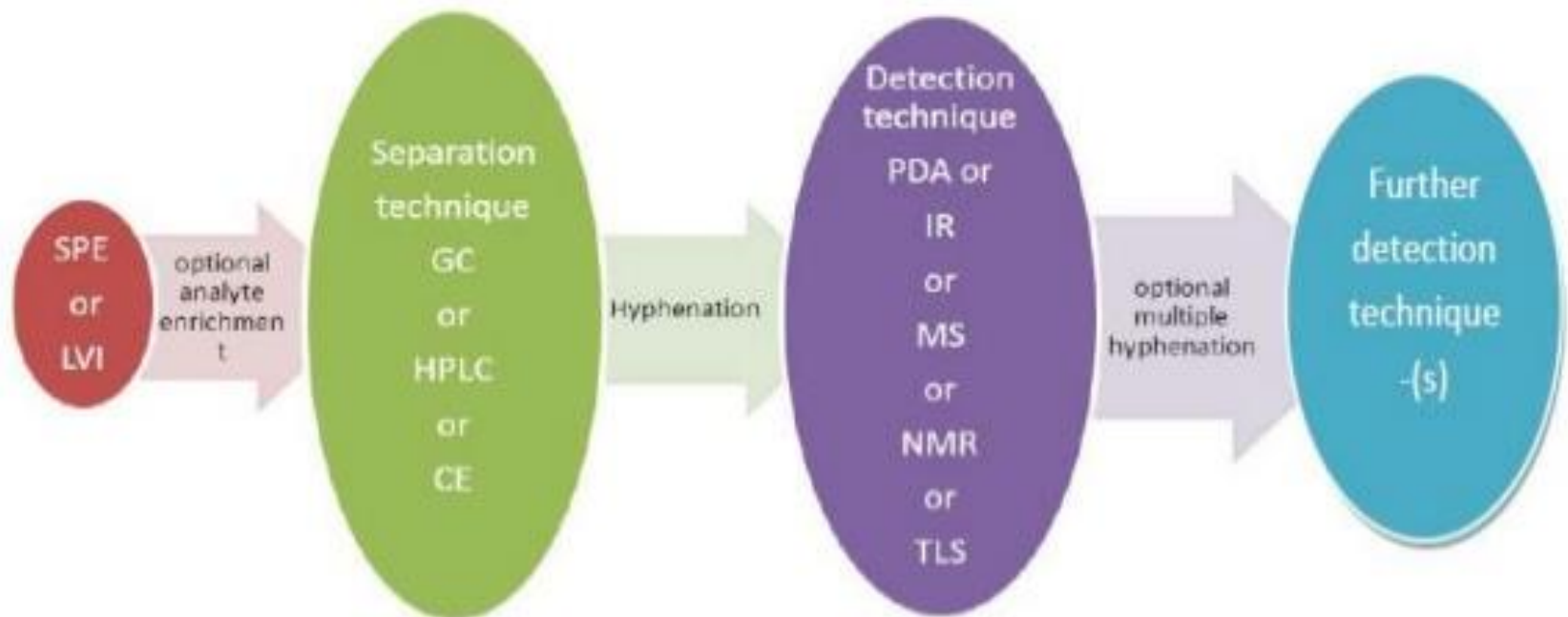

Hyphenated Techniques (LC-ESI-MS)

Separation

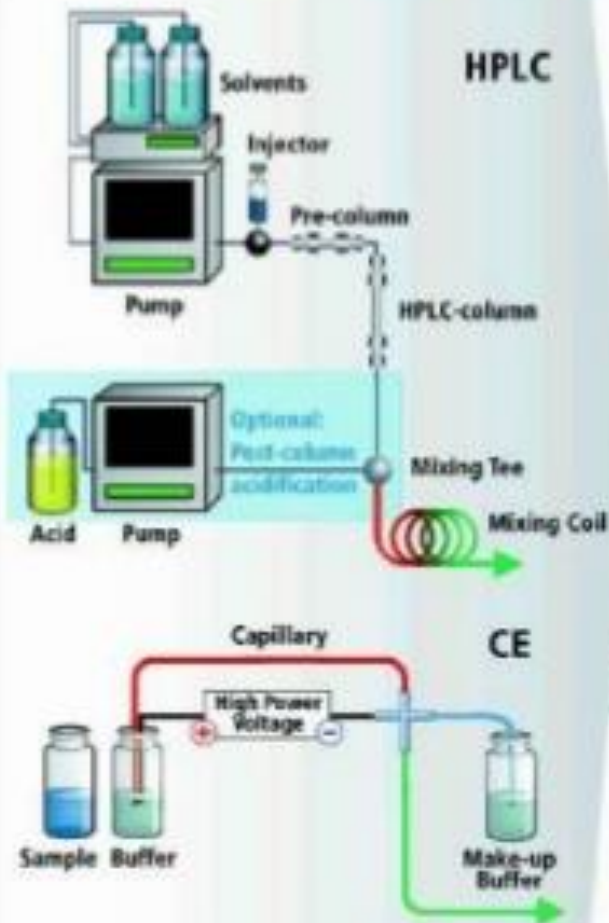

Ionization Electrospray

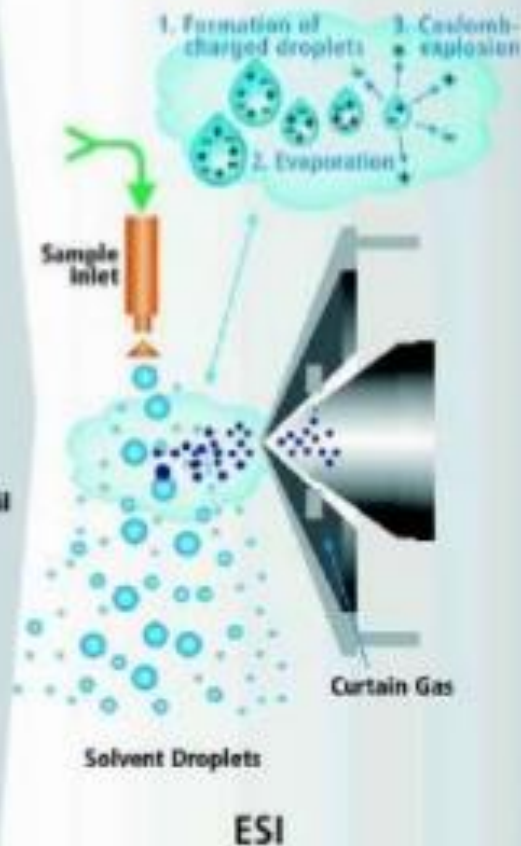

Detection

Triple-Quadrupole-MS

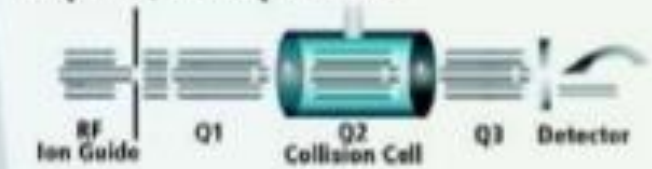

QqTOF-MS

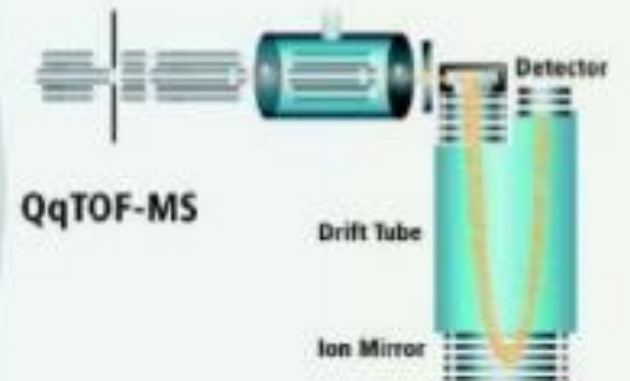

Ion Trap-MS

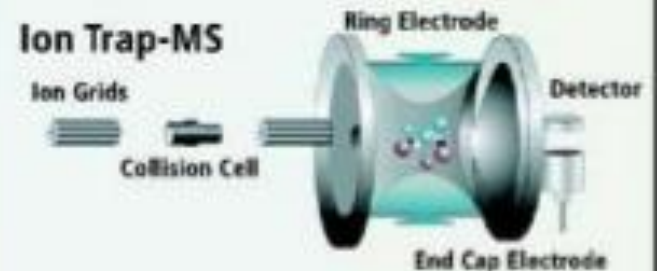

Advantages of Hyphenated Techniques

1. Fast and accurate analysis
2. Higher degree of automation
3. Higher sample throughput
4. Better reproducibility
5. Reduction of contamination due to its closed System
6. Separation and quantification achieved at same time.

List of Hyphenated Techniques

1. GC-MS
2. LC-MS
3. LC-NMR
4. EC-MS
5. CE-MS
6. GC-IR
7. LC-MS-MS
8. LC-ESI-MALDI-TOF
9. GC-MS-MS
10. GC-NMR
11. GC-AES
12. ICP-MS
13. ICP-AAS
14. ICP-OES

2nd Day

- **The Aim of the Study**
- **Solvent Systems**
- **HPLC Analysis Parameters**
- **Sample Preparation**
- **HPLC columns**
- **Chromatography Stationary Phases**
- **Normal vs. Reversed Phase Chromatography**

➤ The Aim of the Study

□ Analytical Chemistry

Analytical chemistry studies and uses instruments and methods used to separate, identify, and quantify matter. In practice, separation, identification or quantification may constitute the entire **analysis** or be combined with another method.

❖ **Bioanalytical Assay**

- Quantitative measurement of
Xenobiotics (Drugs and their metabolites, and biological molecules in unnatural locations or concentrations)
- (ii) Biotics (Macromolecules, Proteins, DNA, Large molecule drugs, metabolites) in Biological systems.

➤ Solvent Systems

- ✓ Deionized water / Double distilled water / Sonication / Filtration
- ❖ Single solvent (Usually washing/pumping purpose)
- ❖ Usually a mixture of two **solvents** (One polar and one non-polar)
- ❖ Occasionally, a mixture of three **solvents** can be used
- ❖ Buffer solvents
- Isocratic solvent system (A : B is always same)
- Gradient solvent system can be designed as follows

Time (min)	Water (0.1 % formic acid) %	Acetonitrile (0.1 % formic acid) %
5	95	5
35	65	35
40	5	95
45	5	95
50	65	35
55	95	5
60	95	5

➤ HPLC Analysis Parameters

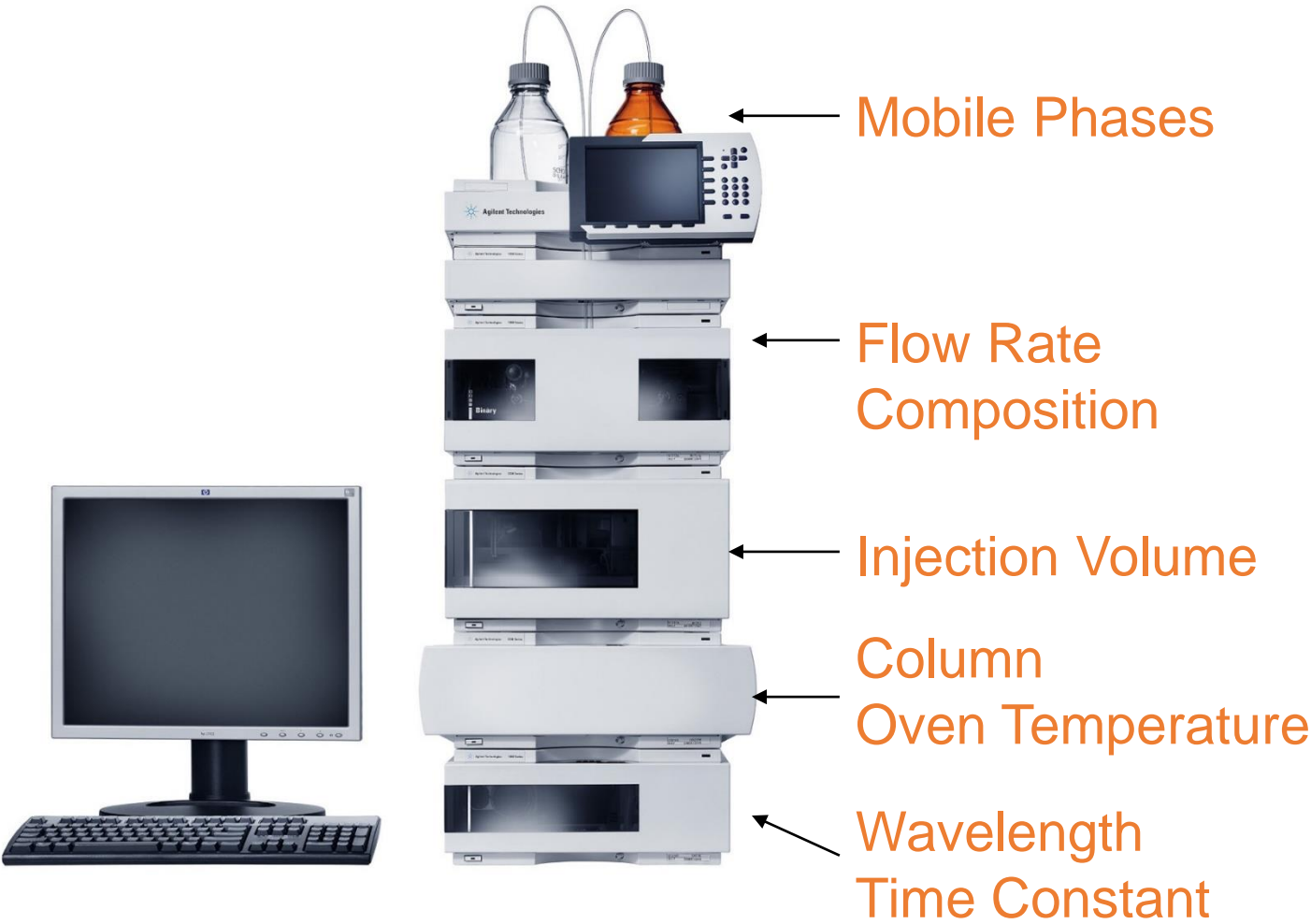

➤ Sample Preparation

- ✓ Suitable for injection to the column
- ✓ Homogenous mixture
- ✓ Free from interference
- ✓ Will not damage column
- ✓ Solubility (for Solid)
- ✓ Should dissolve in appropriate solution
- ✓ Need 1 mL vial
- ✓ Vortex
- ✓ Sonication
- ✓ Centrifugation
- ✓ Filtration
- ✓ Concentration (at least in PPM; parts per million)
- ✓ Mixture in mobile phase
- ✓ Etc.

➤ HPLC columns

✓ *Knowledge of sample*

- Structure of sample components?
- Number of compounds present?
- Sample matrix?
- pK_a values of sample components?
- Concentration range?
- Molecular weight range?
- Solubility?
- Other pertinent data?

Column Dimension

- **Short** (30-50mm) - *short run times, low backpressure*
- **Long** (250-300mm) - *higher resolution, long run times*
- **Narrow** ($\leq 2.1\text{mm}$) - *higher detector sensitivity*
- **Wide** (10-22mm) - *high sample loading*

➤ Chromatography Stationary Phases

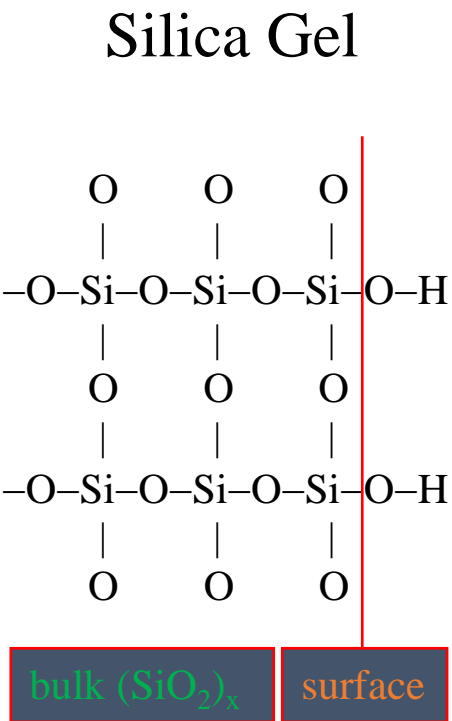

relatively *polar* surface
 “normal phase”

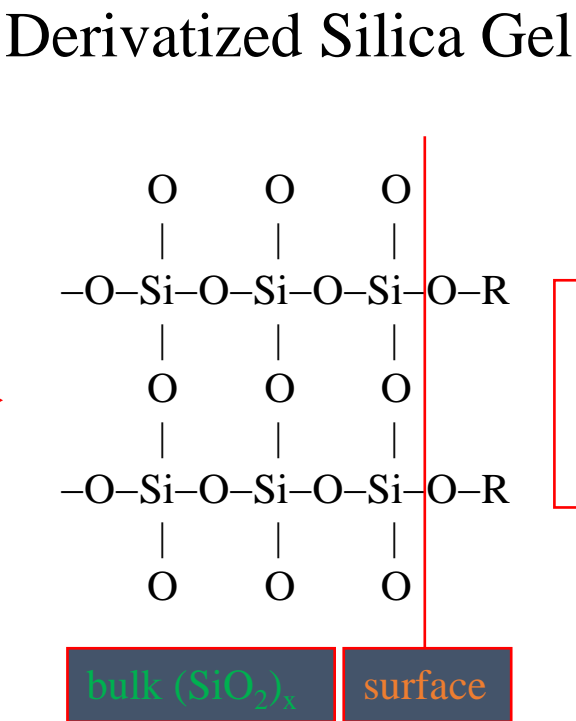

relatively *nonpolar* surface
 “reversed phase”

Where R = C₁₈H₃₇
 hydrocarbon chain
 (octadecylsilyl deriv.
 silica or “C18”)



➤ HPLC columns

Reversed Phase HPLC Columns

- C-18, C-8: Rugged, general purpose, highly retentive
- C-3, C-4: Less retentive, used mostly for peptides & proteins
- Phenyl: Greater selectivity than alkyl-bonded
- Cyano: Moderate retention, normal & rev. phase
- Amino: Weak retention, good for carbohydrates

The cyano column with a high polarity mobile phase (Water/MeOH) will act as a reversed phase column.

➤ Normal vs. Reversed Phase Chromatography

	Normal Phase	Reversed Phase
Stationary phase	Polar (silica gel)	Non-polar (C18)
Mobile phase	Non-polar (organic solvents)	Polar (aqueous/organic)
Sample movement	Non-polar fastest	Polar fastest
Separation based on	Different polarities (functionality)	Different hydrocarbon content

3rd Day

What is Mass Spectrometry (MS)

- ✓ An analytical technique that ionizes chemical species
- ✓ MS does not measure the mass of a compound but sorts the ions based on their mass-to-charge ratio
- ✓ A mass spectrum measures the masses within a sample
- ✓ Applied to pure samples as well as complex mixtures
- ✓ A sample (solid, liquid, or gas) is ionized
- ✓ Determination of the elemental or isotopic signature of a sample,
- ✓ Elucidate the chemical structures of a molecules (organic, inorganic and biological molecules)
- ✓ Compounds have distinctive fragmentation patterns that provide structural information
- ✓ The qualitative and quantitative composition of complex mixtures

What is Mass Spectrometry (MS)

- ❖ MS – has emerged as an ideal technique for the identification of almost all structurally diverse metabolites.
- ❖ Due to its superb speed, high selectivity and high sensitivity, MS has become the method of choice in drug discovery and development
- ❖ To identify, verify, and quantitate: metabolites, recombinant proteins, proteins isolated from natural sources, oligonucleotides, drug candidates, peptides, synthetic organic chemicals, polymers, etc.

Applications of Mass Spectrometry

Pharmaceutical analysis

- Bioavailability studies

- Drug metabolism studies, pharmacokinetics

- Characterization of potential drugs

- Drug degradation product analysis

- Screening of drug candidates

- Identifying drug targets

Biomolecule characterization

- Proteins and peptides

- Oligonucleotides

Environmental analysis

- Pesticides on foods

- Soil and groundwater contamination

Forensic analysis/clinical

Essential Parameters for Sample Analysis

- ❖ Mass spectrophotometer:
Agilent technologies 1200 series LC coupled with
Agilent 6320 ion trap MS
- ❖ Ion source: Electrospray Ionization (ESI)
- ❖ Column used: Eclipse XDB-C18 (150 x 4.6 mm, 5 μ m)
- ❖ Solvent system: Gradient solvent system (ACN:H₂O)
- ❖ Flow rate: 0.4 mL/min.
- ❖ Run time: 60 min.
- ❖ Capillary temperature: 325°C
- ❖ Dry gas flow rate: 10.0 L/min
- ❖ Nebulizer pressure: 40 psi
- ❖ Maximum accumulation time: 300,000 μ s
- ❖ Spectra collection: positive/negative mode
- ❖ Scan ranges: 50-500 m/z
- ❖ Injection volume: 2 μ L

How does a mass spectrometer work?

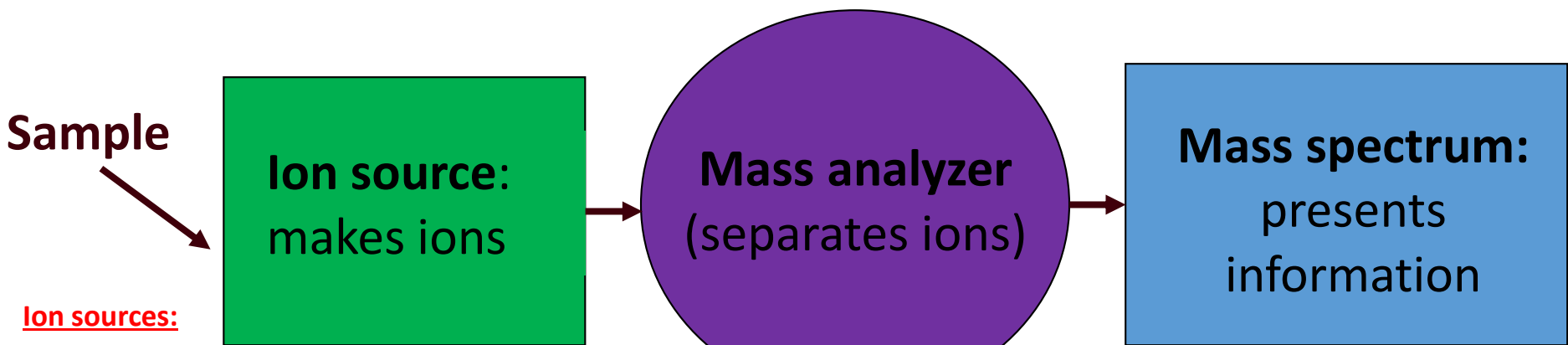

Ion sources:

- ❖ Electron Impact (EI)
- ❖ Chemical Ionization (CI)
- ❖ Field Ionization (FI)
- ❖ Field Desorption (FD)
- ❖ Electrospray (ESI)
- ❖ Atmospheric Pressure Ionization (API)
- ❖ Atmospheric Pressure Chemical Ionization (APCI)
- ❖ Photo-ionization (APPI)
- ❖ Matrix Assisted Laser Desorption and Ionization (MALDI)
- ❖ Inductively coupled plasma ionization (ICP)
- ❖ Secondary Ion Mass Spectrometry (SIMS)
- ❖ Etc.

- ✓ Ion Traps
- ✓ Triple Quadrupole,
- ✓ QTOF (Time-of-Flight),
- ✓ QTRAP Linear Ion Trap
- ✓ Orbitrap

Mass Spectrometer Block Diagram

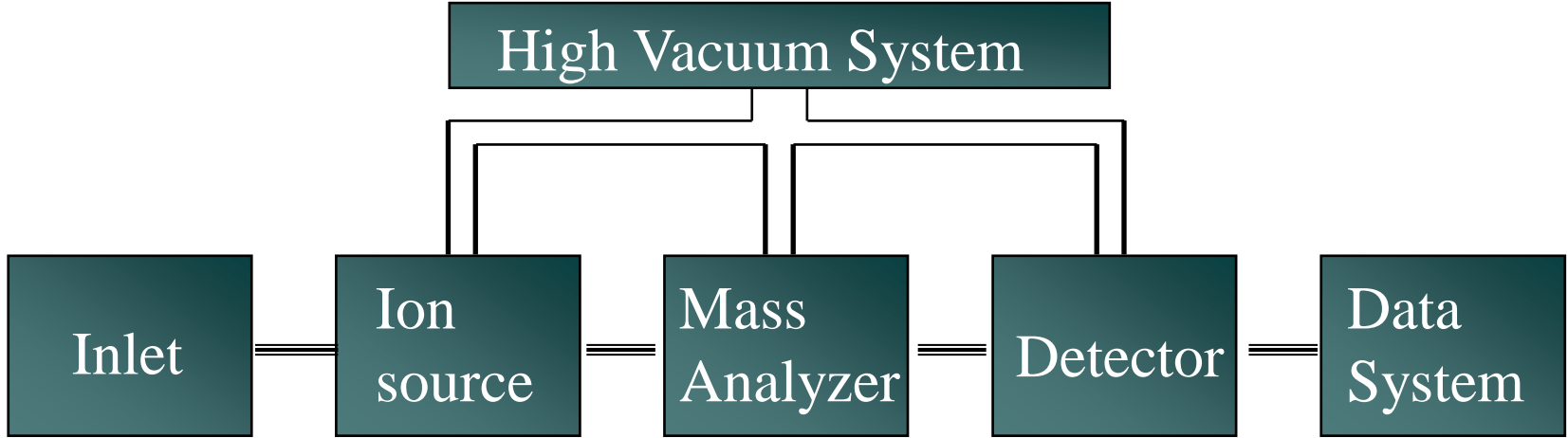

Summary: acquiring a mass spectrum

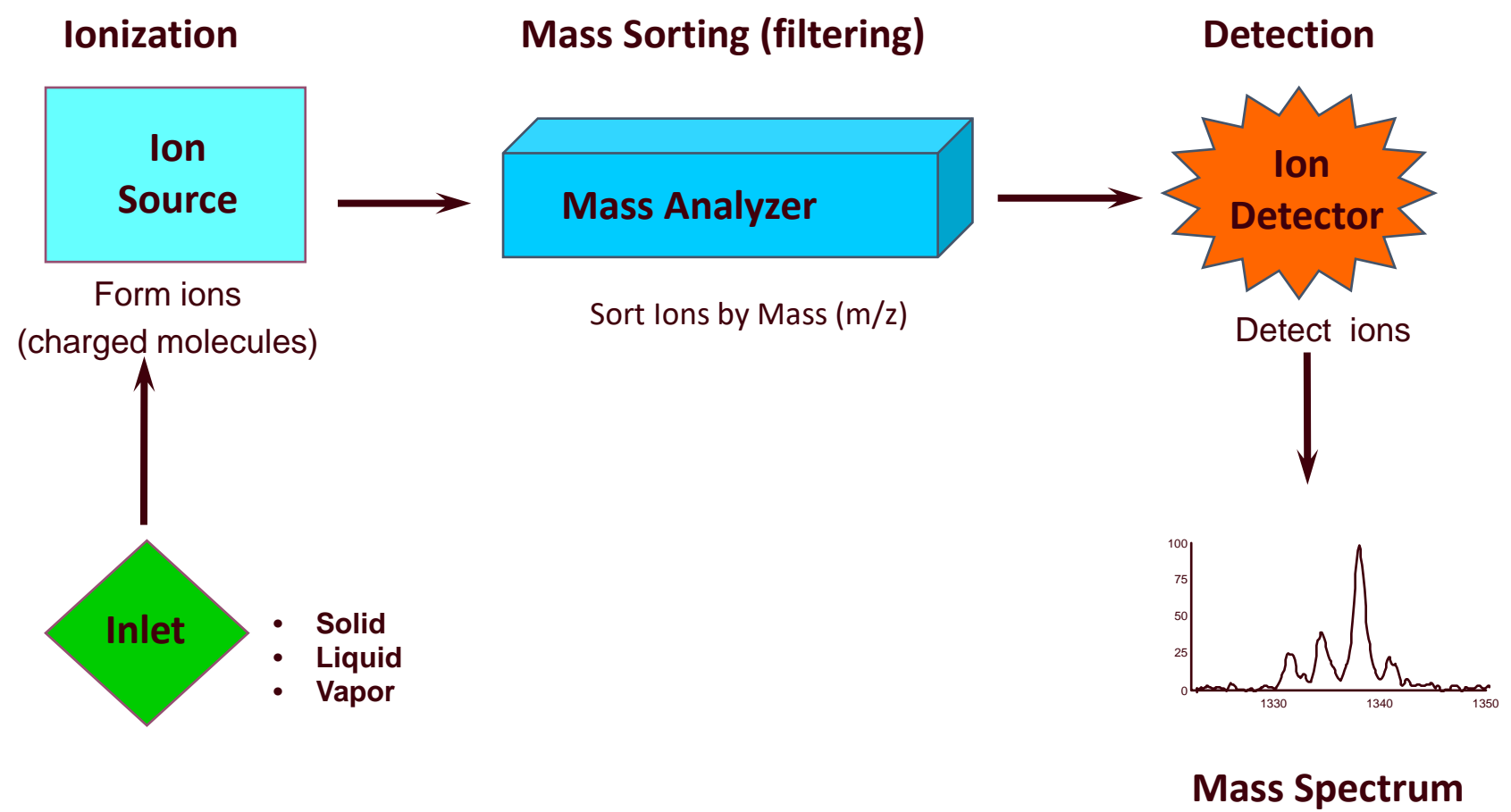

Ion trap mass spectrometers

Ions entering the chamber are trapped there by electromagnetic fields

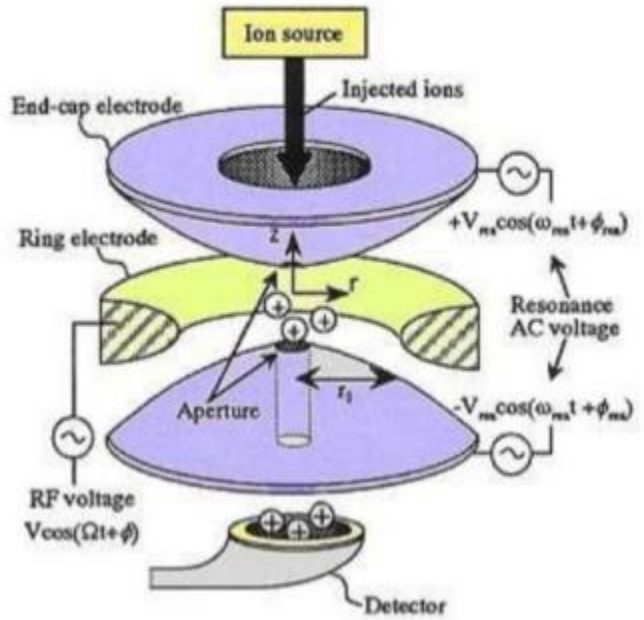

TOF (Time-of-Flight)

Sorting of ions is done in absence of magnetic fields

Triple Quadrupole

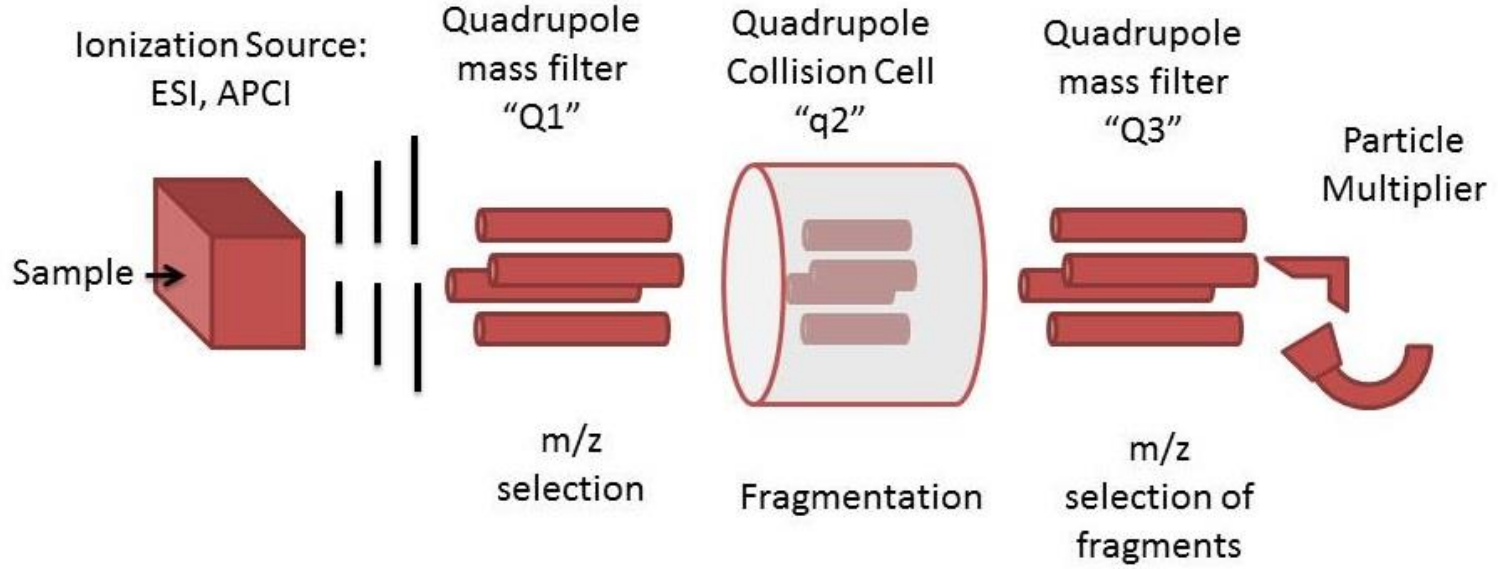

Ion Sources make ions from sample molecules

(Ions are easier to detect than neutral molecules)

Electrospray ionization:

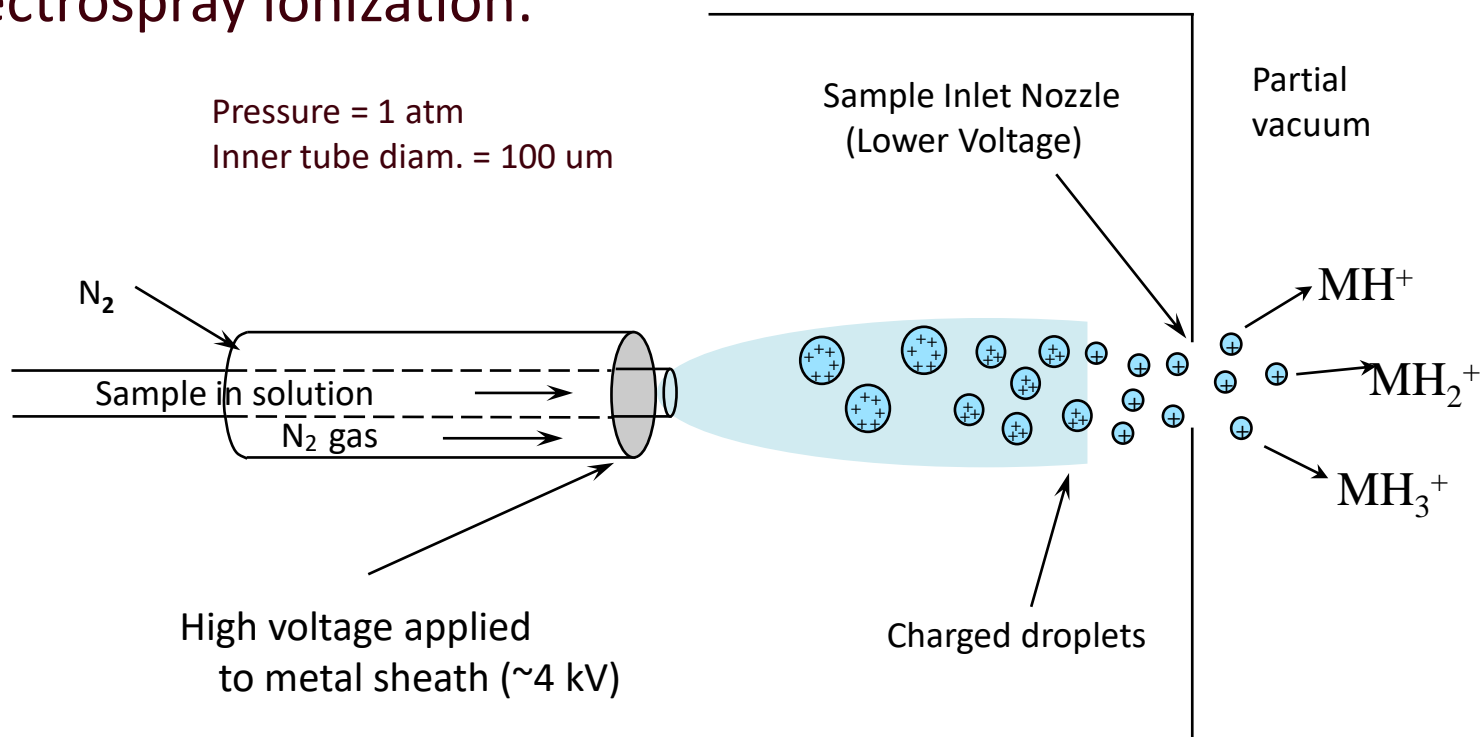

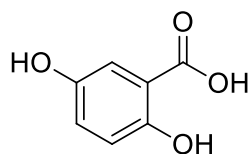
In vivo* Distribution Study*Matrix Selection & Optimization**

2,5-Dihydroxybenzoic acid
(DHB)

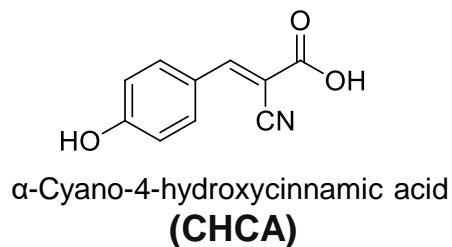

α -Cyano-4-hydroxycinnamic acid
(CHCA)

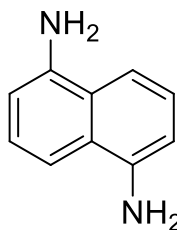

1,5-Diaminonaphthalene
(DAN)

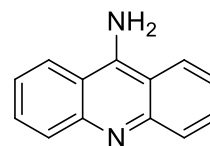

9-Aminoacridine
(AA)

Laser energy applied (μ J)	Best ionization
5	-
6	DAN
7	-
8	-
9	-
10	DHB
12	-
15	-
20	-
25	-

In vivo Distribution Study

Sample Loading to the MALDI Target Plate

➤ Dried droplet (original method)



In vivo Distribution Study

Sample Loading to the MALDI Target Plate

➤ On-plate mixing

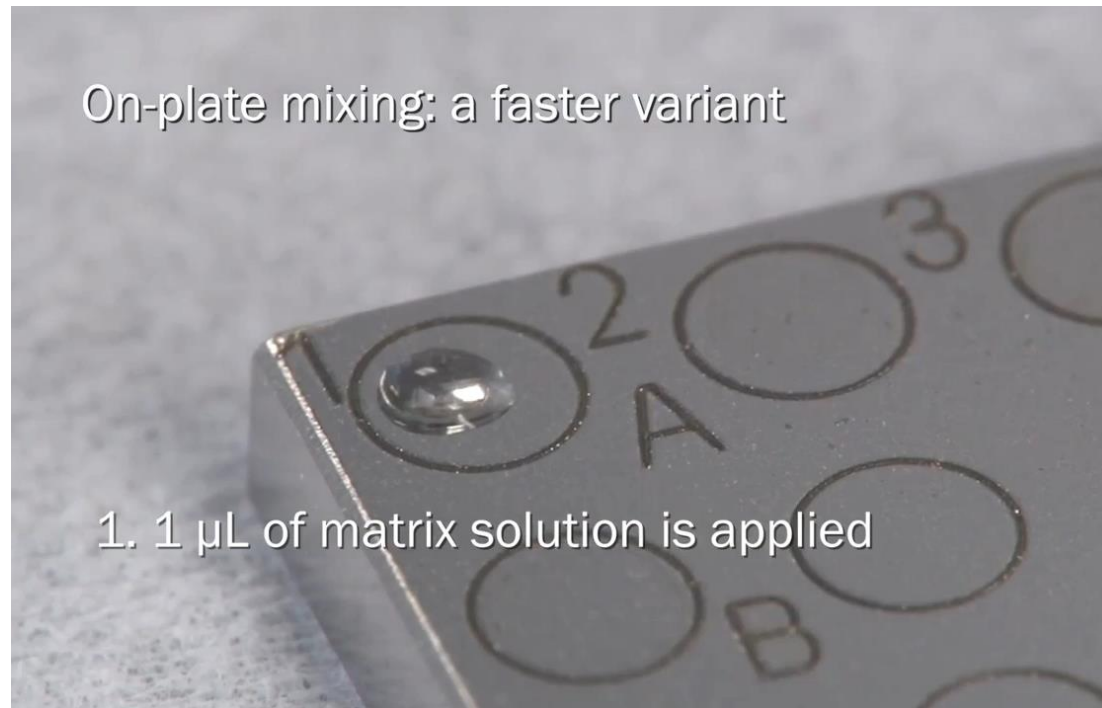

In vivo Distribution Study

Sample Loading to the MALDI Target Plate

➤ Thin-layer (fast evaporation)

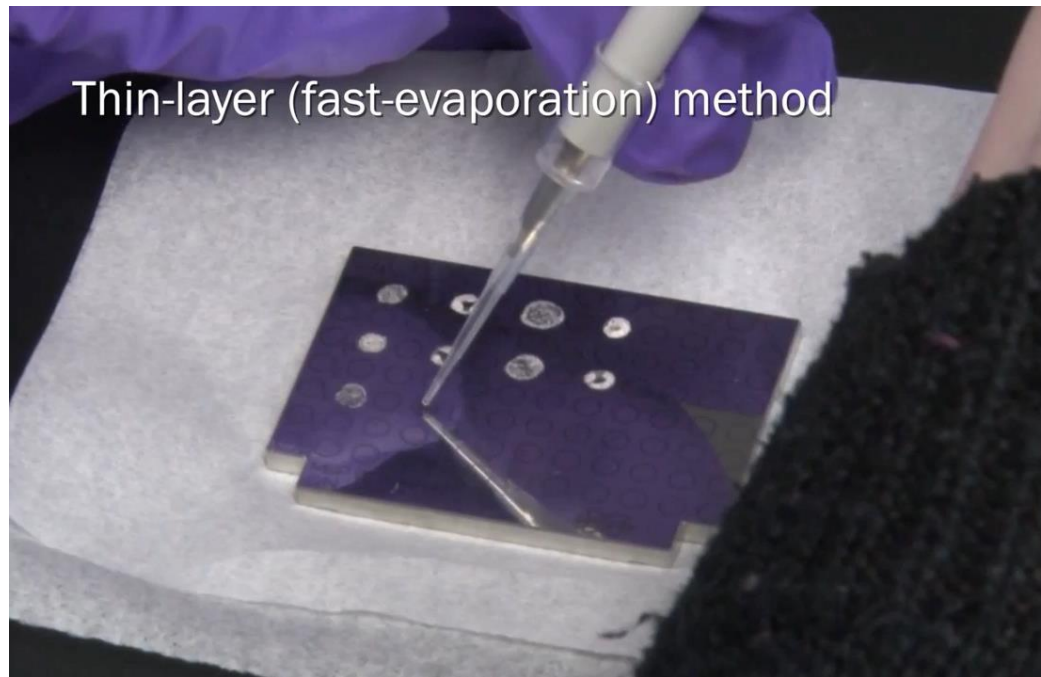

In vivo Distribution Study

MALDI: Matrix Assisted Laser Desorption Ionization

- Laser irradiation forms an excited plume
- Proton transfers from / to the matrix forms +/- analyte ions

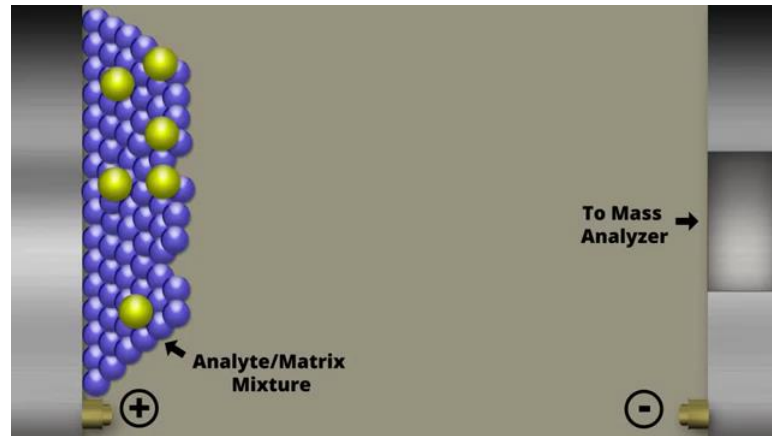

MALDI in *positive* (+) mode

In vivo Distribution Study

LTQ Orbitrap Operation Principle

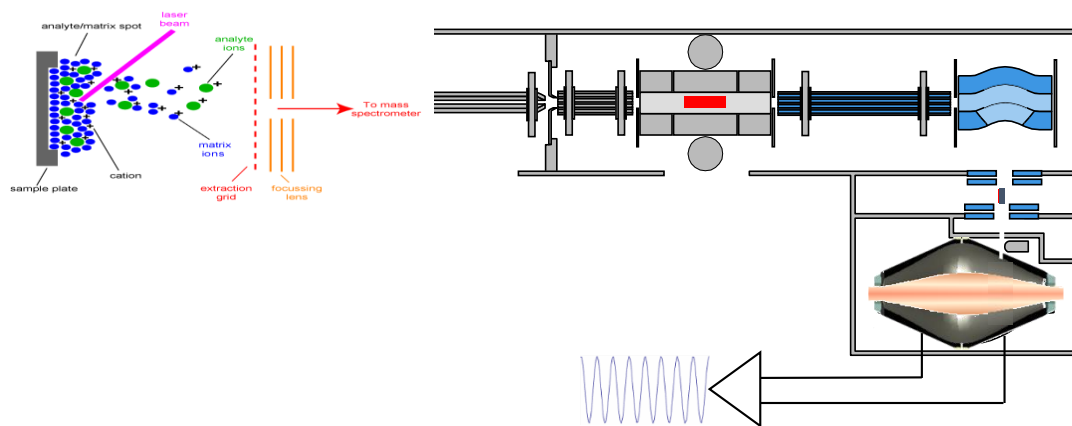

In vivo Distribution Study

Frequencies & Masses

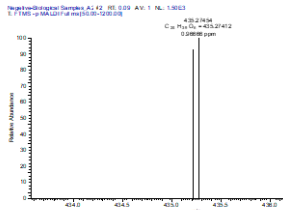

MS spectrum

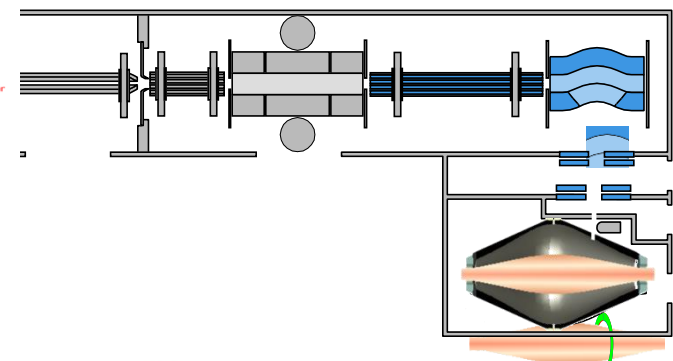
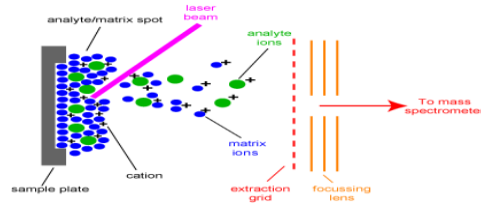

$$\omega = \sqrt{\frac{k}{m/z}}$$

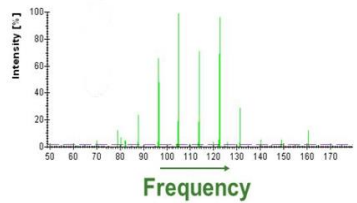

Frequency domain signal

Fourier Transformation (FT)

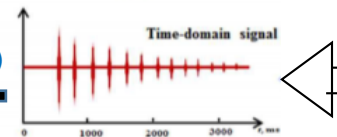

MALDI: Matrix Assisted Laser Desorption Ionization

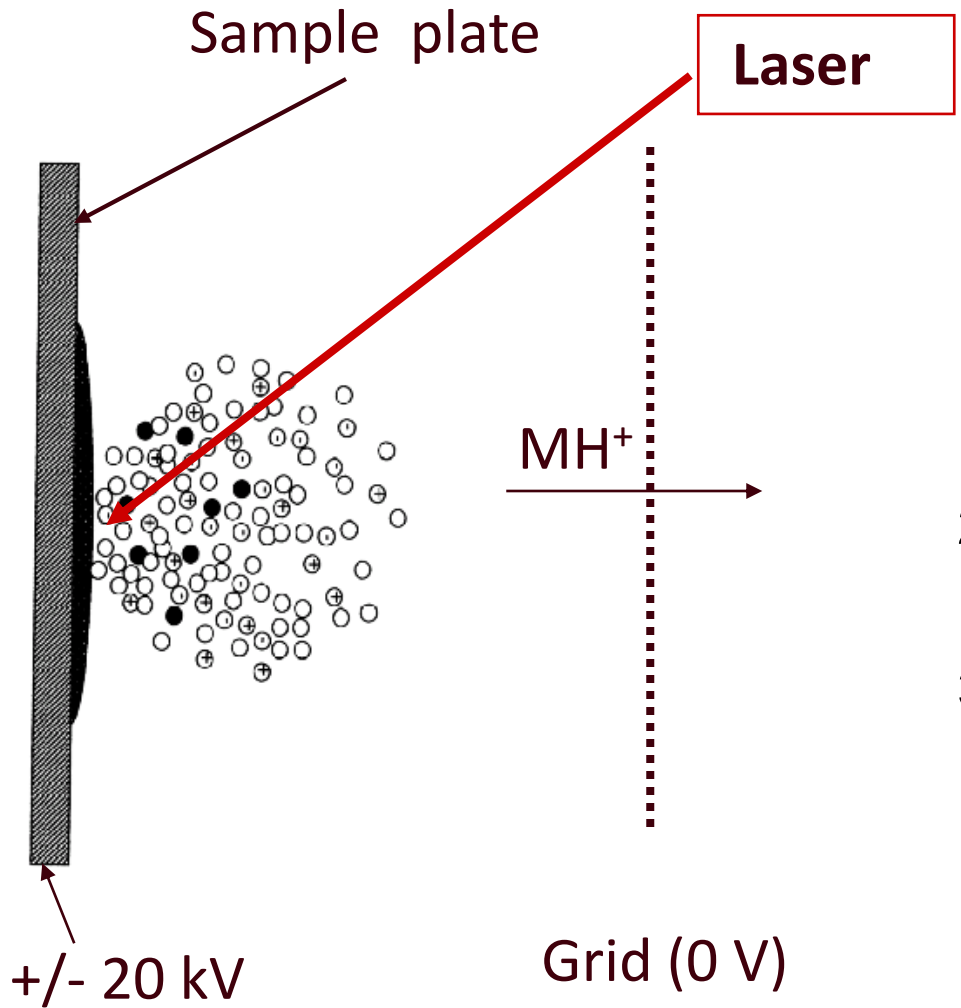

1. Sample is mixed with matrix (X) and dried on plate.
2. Laser flash ionizes matrix molecules.
3. Sample molecules (M) are ionized by proton transfer:
 $XH^+ + M \rightarrow MH^+ + X$.

How is mass defined?

Assigning numerical value to the intrinsic property of “mass” is based on using carbon-12, ^{12}C , as a reference point.

One unit of mass is defined as a Dalton (Da).

One Dalton is defined as 1/12 the mass of a single carbon-12 atom.

Thus, one ^{12}C atom has a mass of 12.0000 Da.

Isotopes

Most elements have more than one stable isotope.

For example, most carbon atoms have a mass of 12 Da, but in nature, 1.1% of C atoms have an extra neutron, making their mass 13 Da.

Why do we care?

Mass spectrometers can “see” isotope peaks if their resolution is high enough.

If an MS instrument has resolution high enough to resolve these isotopes, better mass accuracy is achieved.

Stable isotopes of most abundant elements of peptides

Element	Mass	Abundance
H	1.0078	99.985%
	2.0141	0.015
C	12.0000	98.89
	13.0034	1.11
N	14.0031	99.64
	15.0001	0.36
O	15.9949	99.76
	16.9991	0.04
	17.9992	0.20

Ion Source Depends on Sample

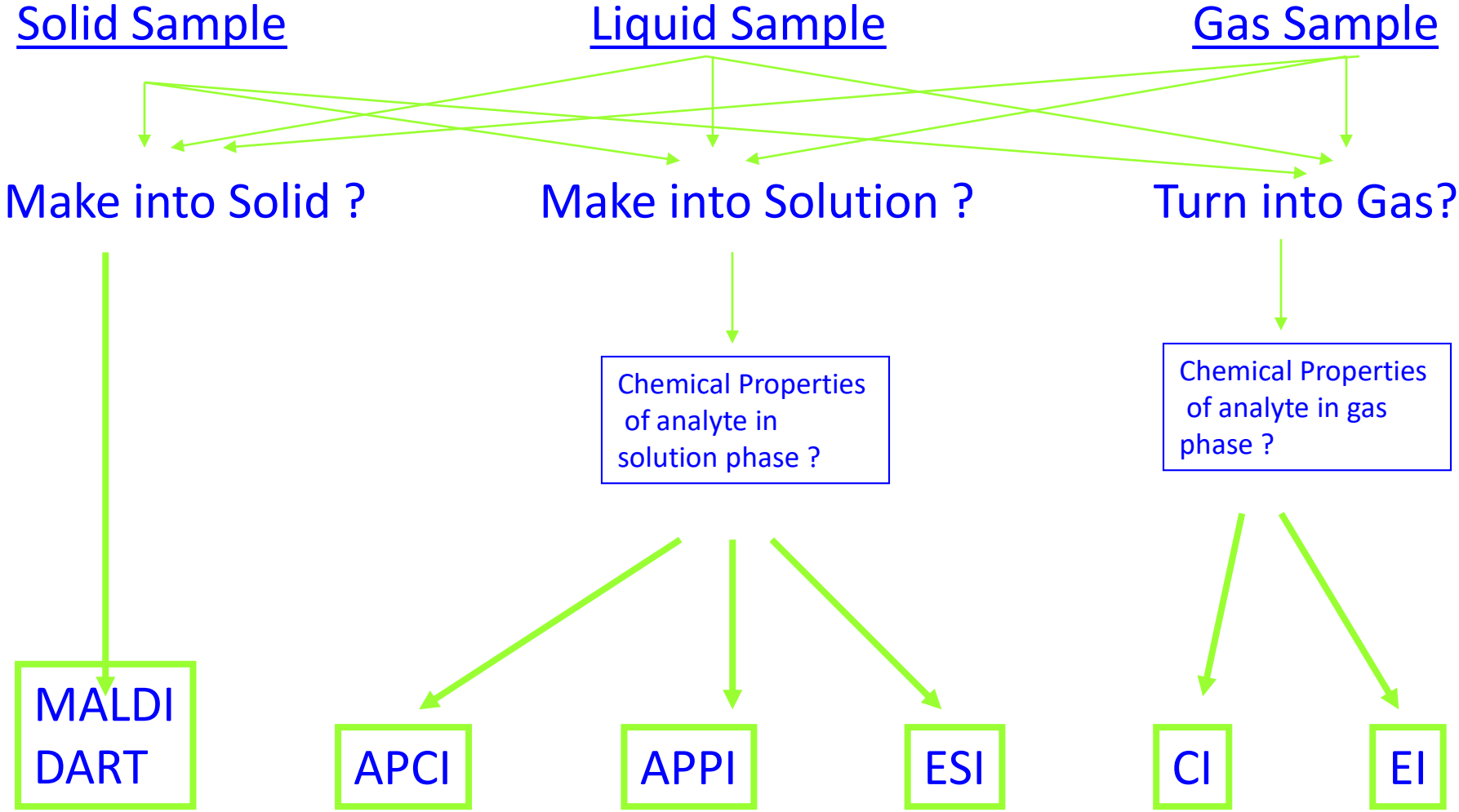

Mass spectrum of peptide with 94 C-atoms (19 amino acid residues)

“Monoisotopic mass”

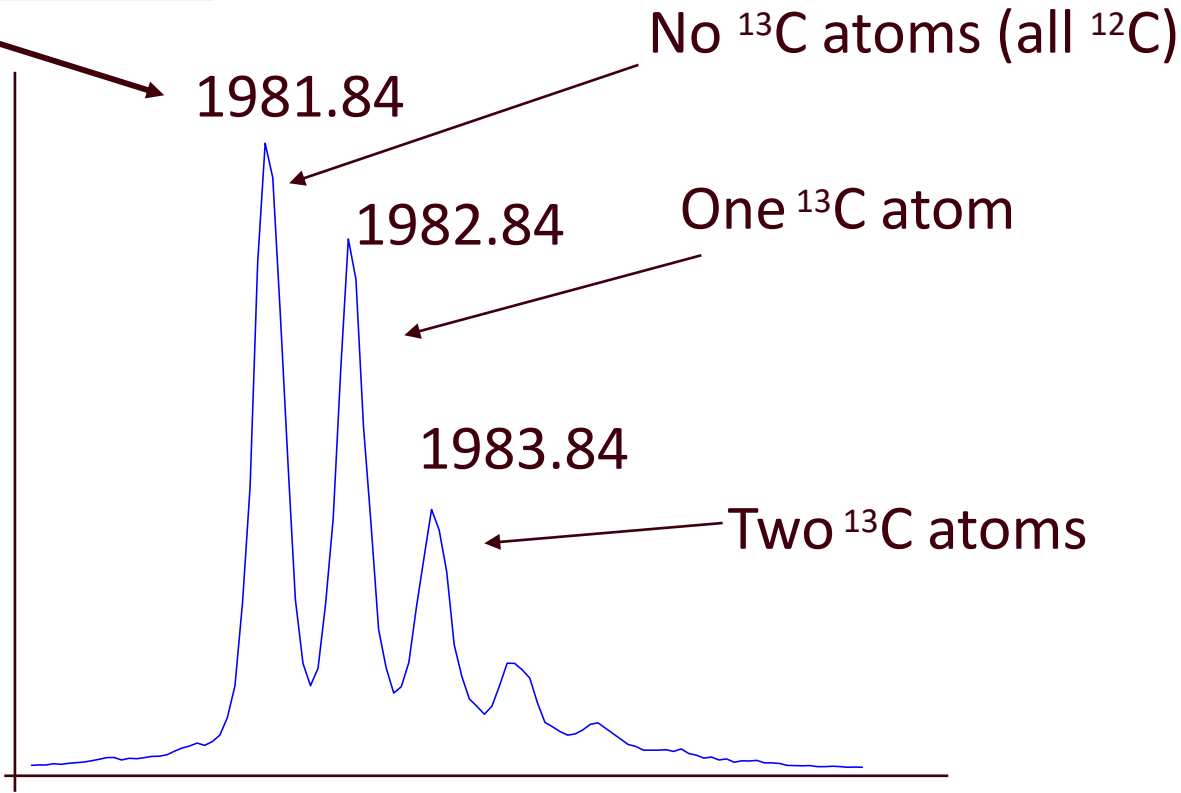

Melatonin

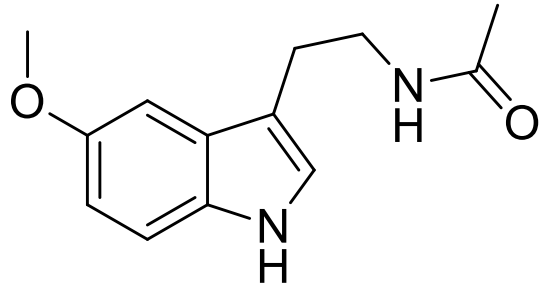

Exact Mass: 232

Melatonin

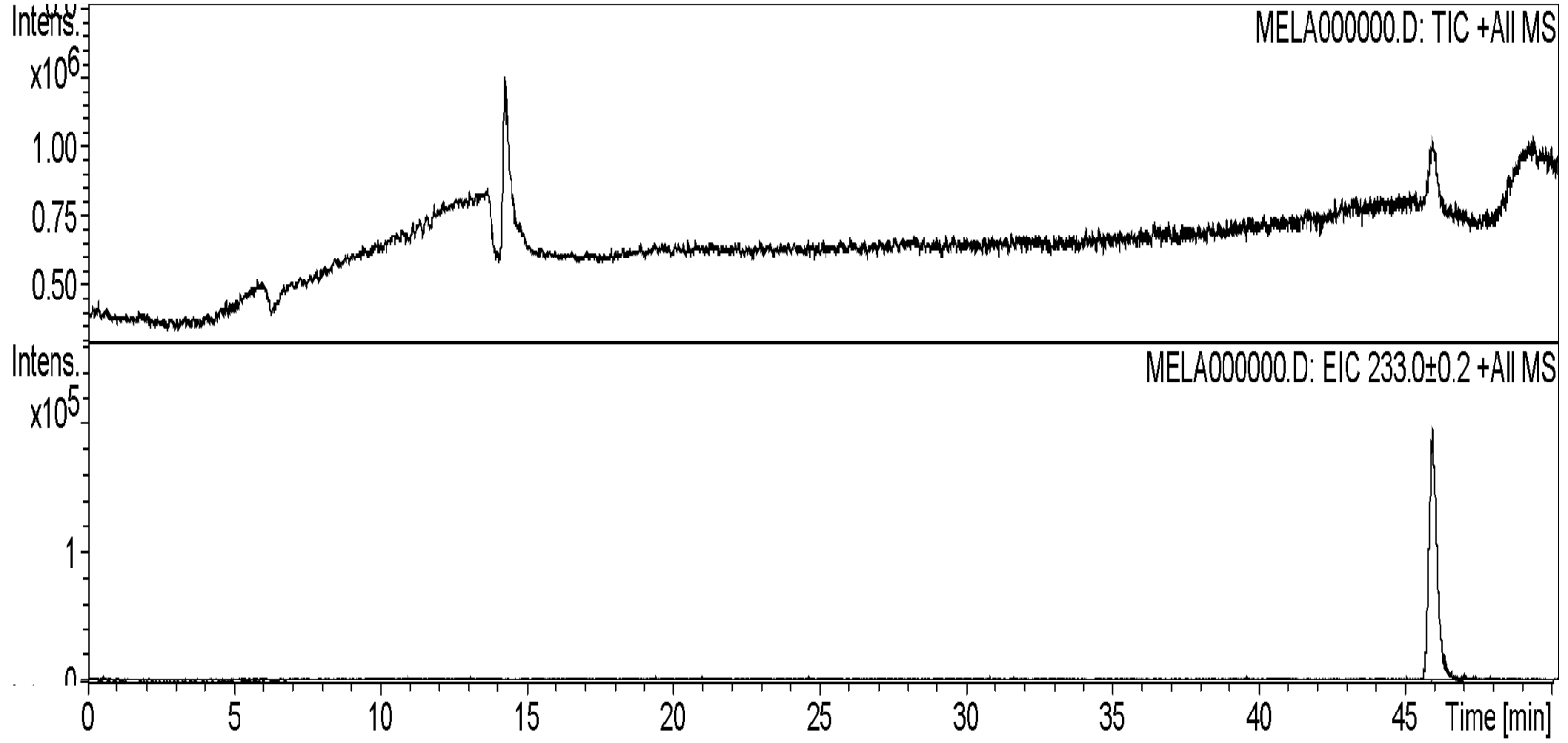

Mass spectra of Melatonin

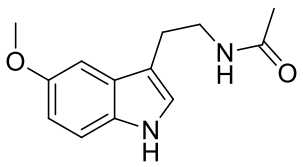

Exact Mass: 232
Melatonin

(A) Direct mass spectra taken in Ion Trap LC-MS;

(B) Mass spectra using column in Ion Trap LC-MS;

(C) Mass spectra using column in triple quad LC-MS;

(D) Mass spectra using DART ion source in Ion Trap mass spectrometry.

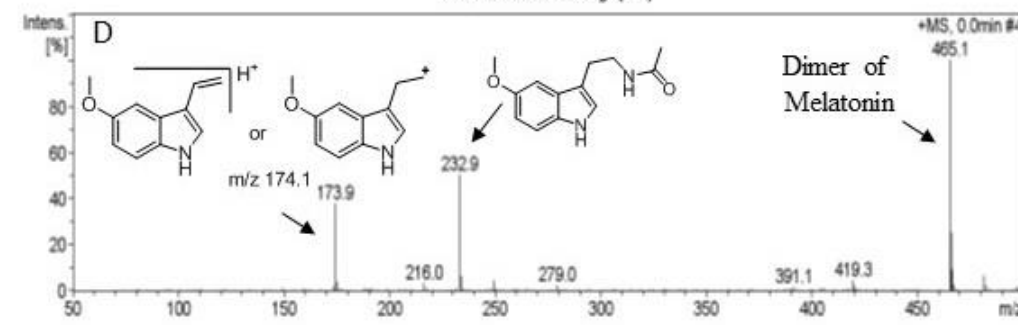
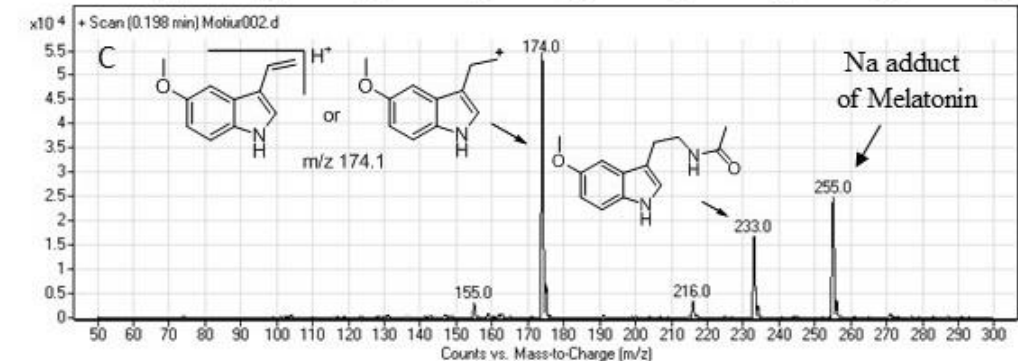
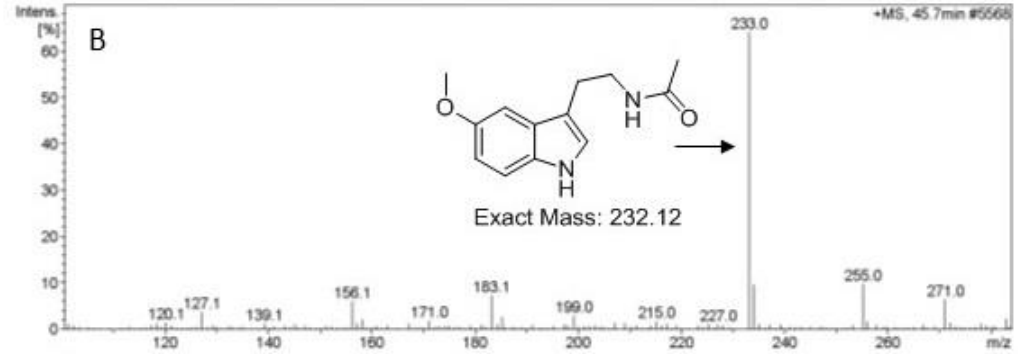
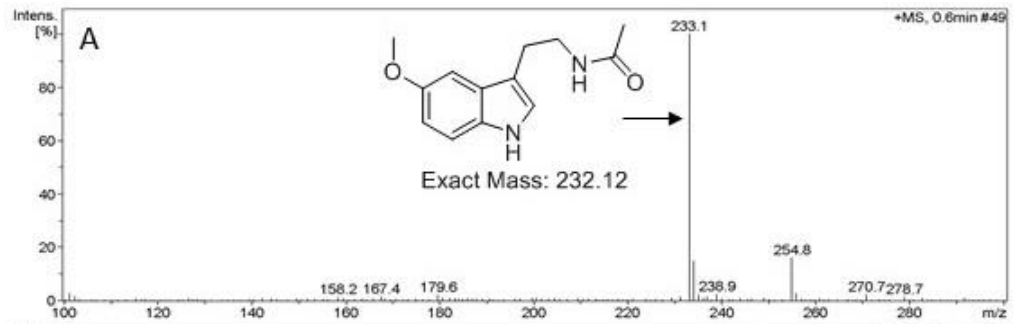

What is MS/MS?

MS/MS means using two mass analyzers (combined in one instrument) to select an analyte (ion) from a mixture, then generate fragments from it to give structural information.

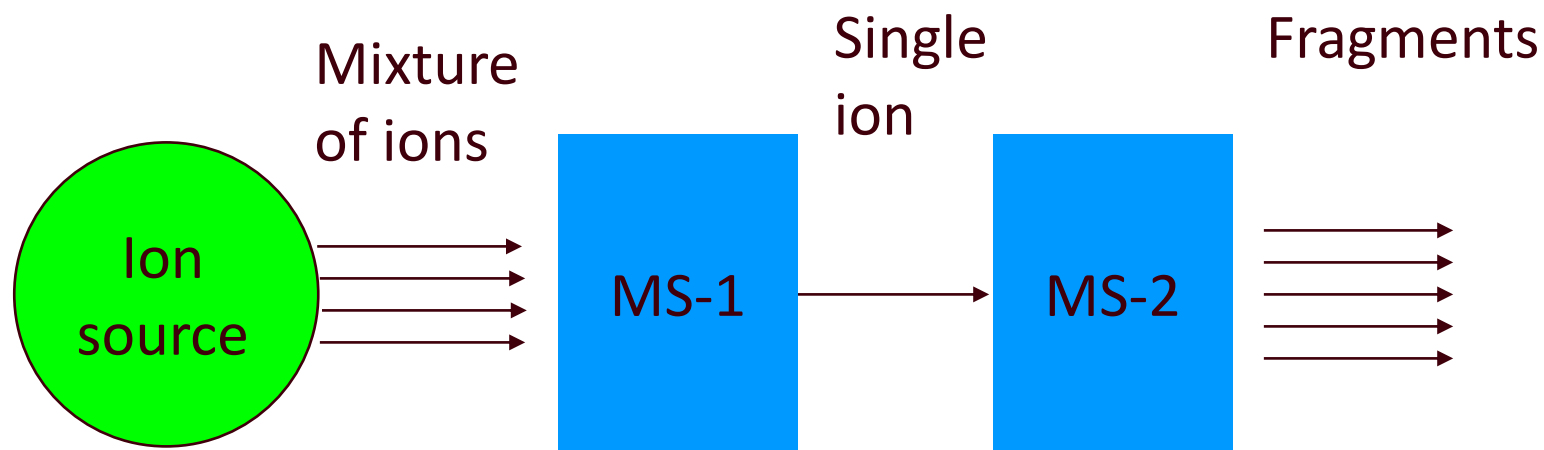

❖ MS/MS data provides tremendous structural information for any drug metabolites

Melatonin

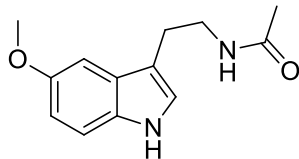

Exact Mass: 232
Melatonin

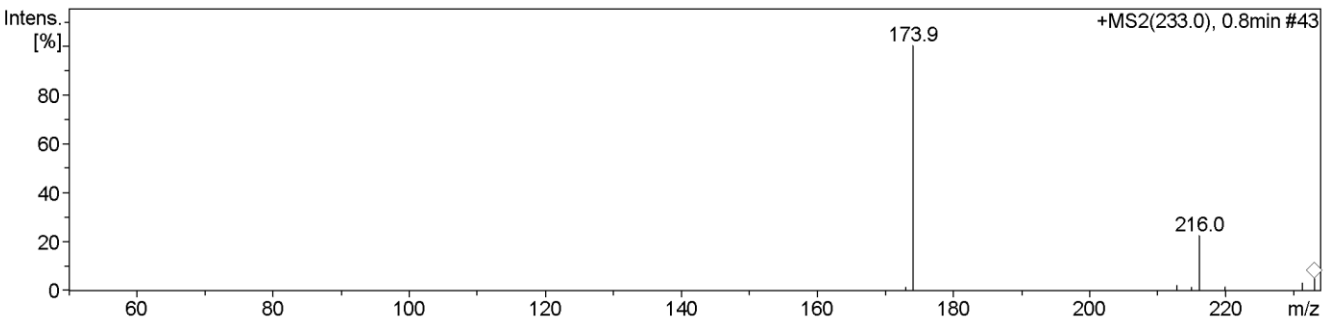
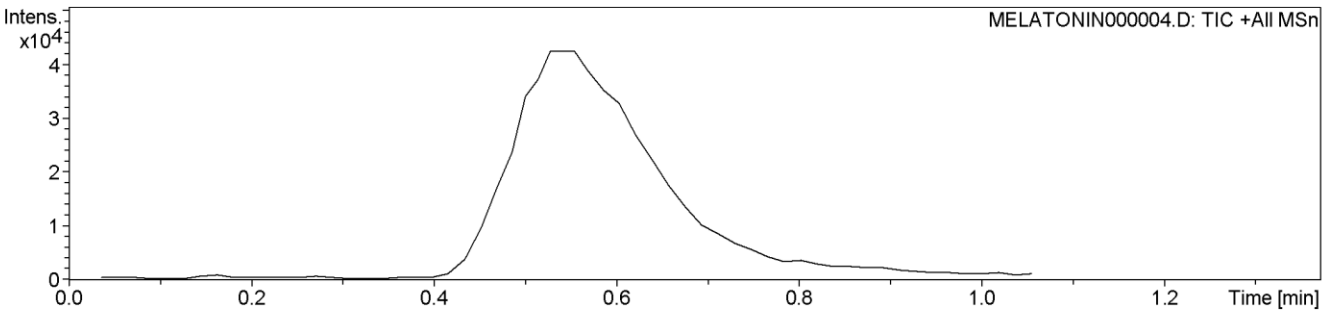

Scheme 1. Mass spectroscopic fragmentation pattern of Melatonin

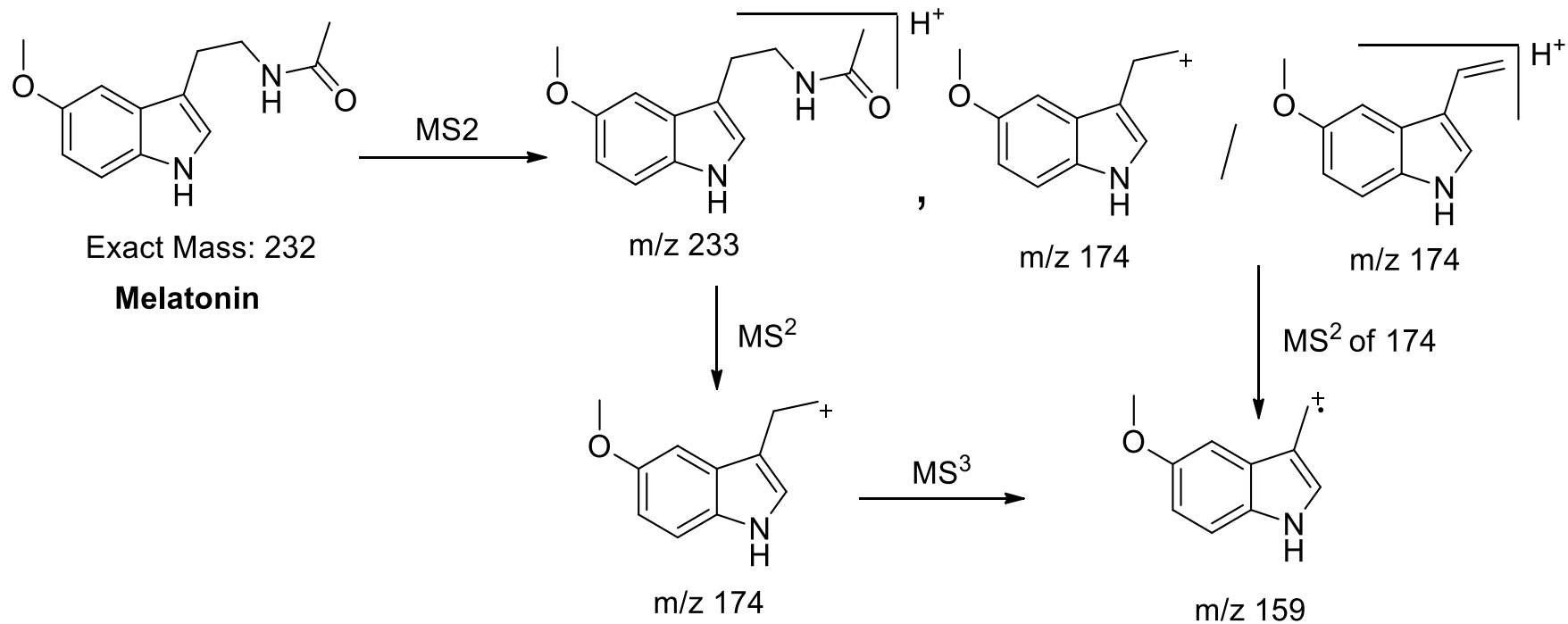

4th Day

Metabolic Profiling

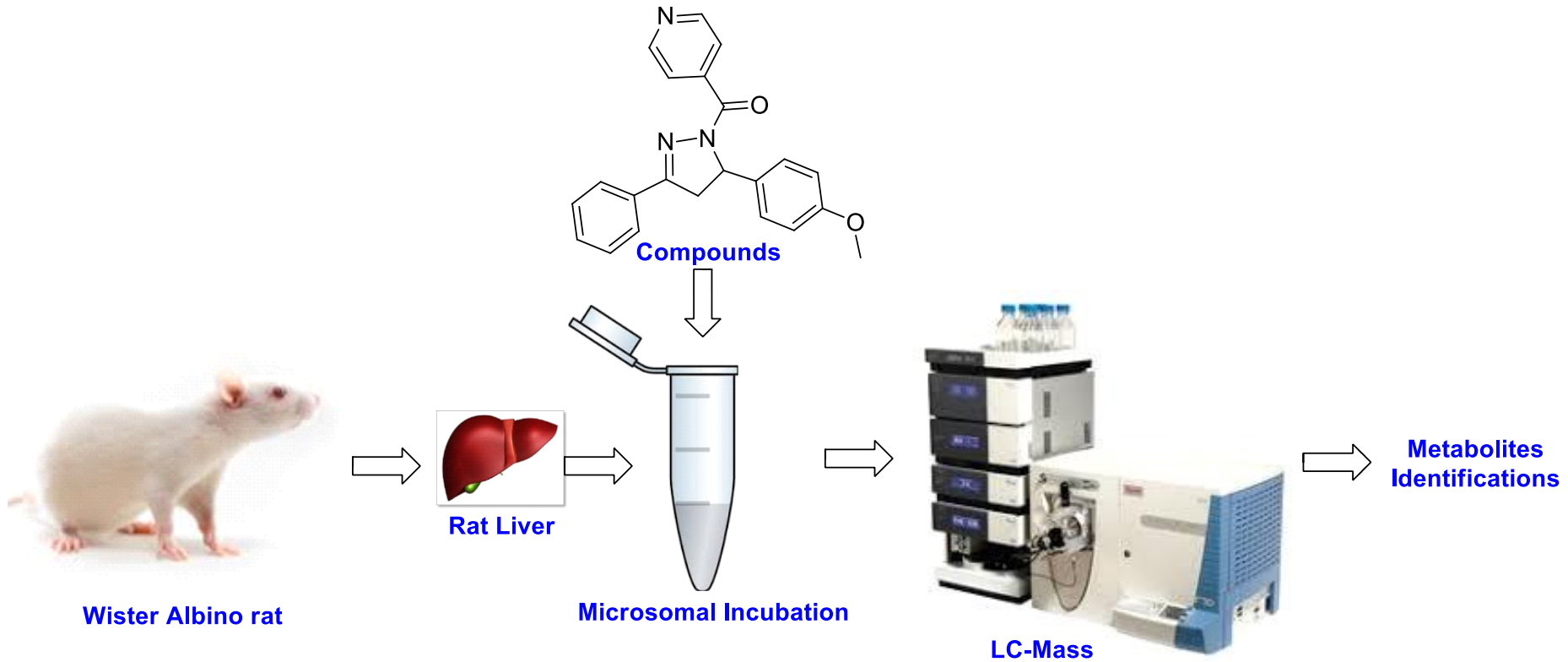

Rat Liver Microsomes

Microsomal Preparation



Rat decapitation

Removal of liver

Homogenization

Centrifuge for 25 min at 25 rpm

Supernatant transferred and pellets discarded

Further centrifugation for 65 min at 49000 rpm

The supernatant discarded and pellets pooled together

Microsomal suspension stored at -70 °C



Microsomal Preparation

Centrifuge for 25 min at 25 rpm

Supernatant transferred and pellets discarded



Further centrifugation for 65 min at 49000 rpm

The supernatant discarded and pellets pooled together

Homogenization

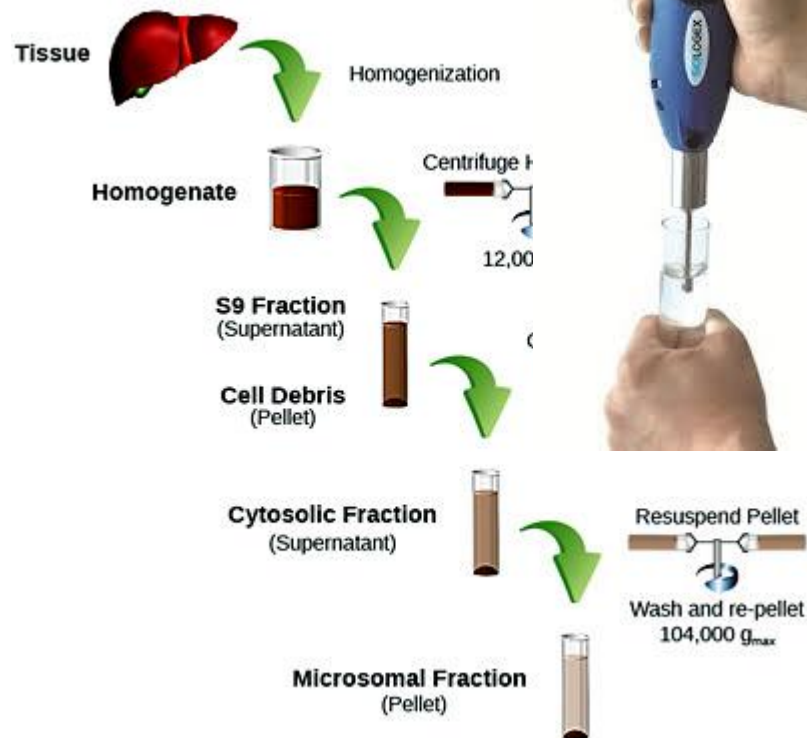

Microsomal suspension stored at -70 °C

Rat liver microsomal incubations of compounds

Incubation type	Microsomes	Compounds	NADPH	MgCl ₂	Buffer
Test 1	40µL	1µL	100µL	100µL	759µL
Test 2	40µL	1µL	100µL	100µL	759µL
Control 1	40µL	0	100µL	100µL	760µL
Control 2	40µL	1µL	0µL	100µL	859µL
Control 3	0 µL	1µL	100µL	100µL	799µL

- ✓ Incubation at 37 °C for 30 min. in a shaking water bath
- ✓ The reaction was terminated by the addition of ice cold acetonitrile
- ✓ Centrifuged for 10 minutes at 14000 rpm
- ✓ Supernatant was transferred to a fresh container
- ✓ Solvent were evaporated under a stream of nitrogen
- ✓ The residue were reconstituted in 1mL with the mobile phase
- ✓ Transferred to HPLC vials for analysis

MS spectra of compound 1

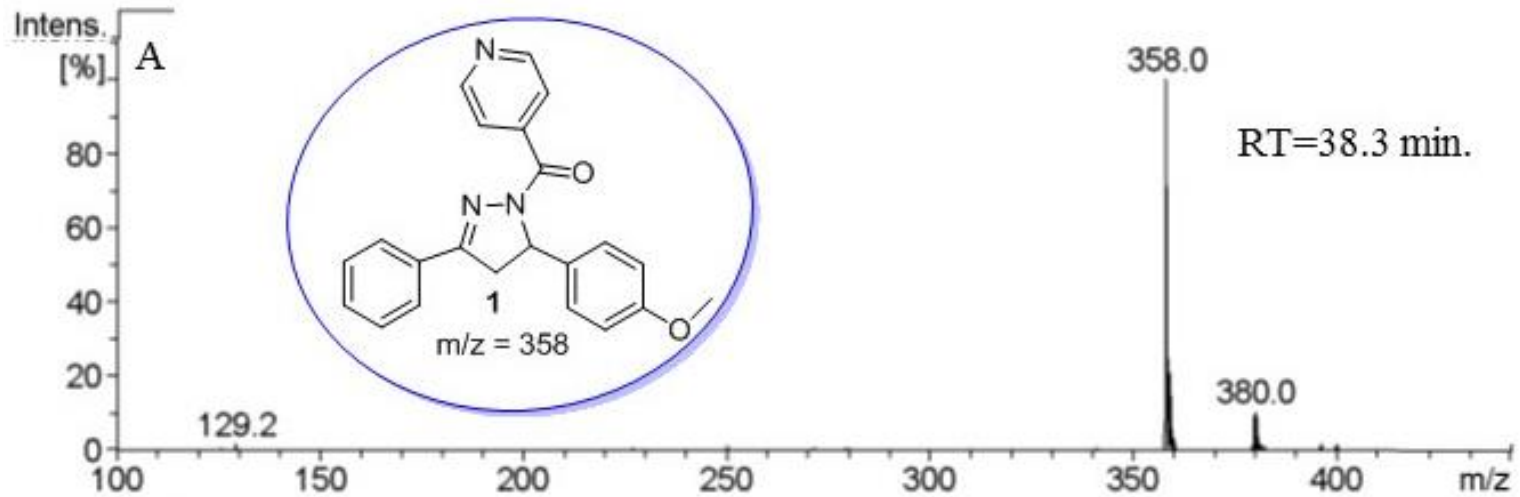
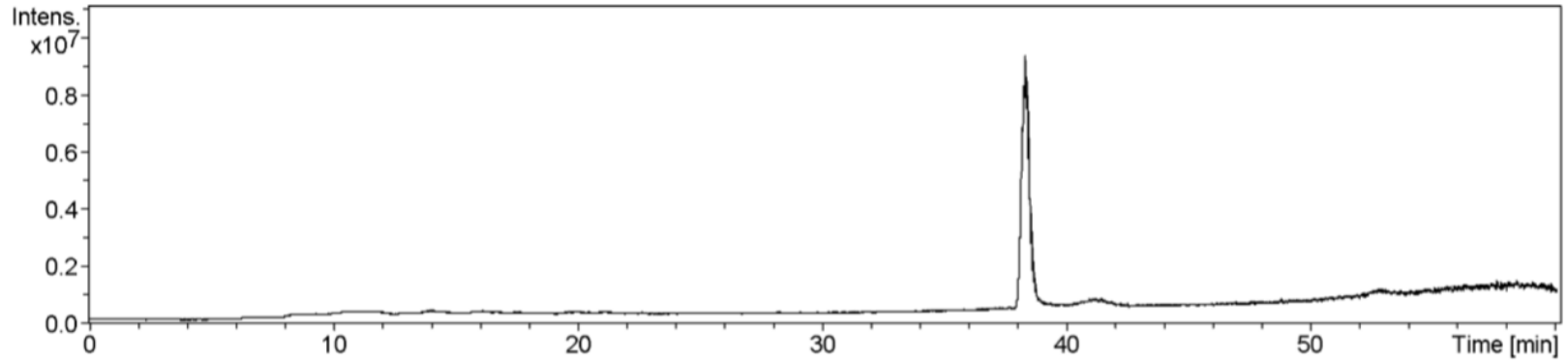

MS² fragmentation pattern of 1

(A); Possible fragments of 1

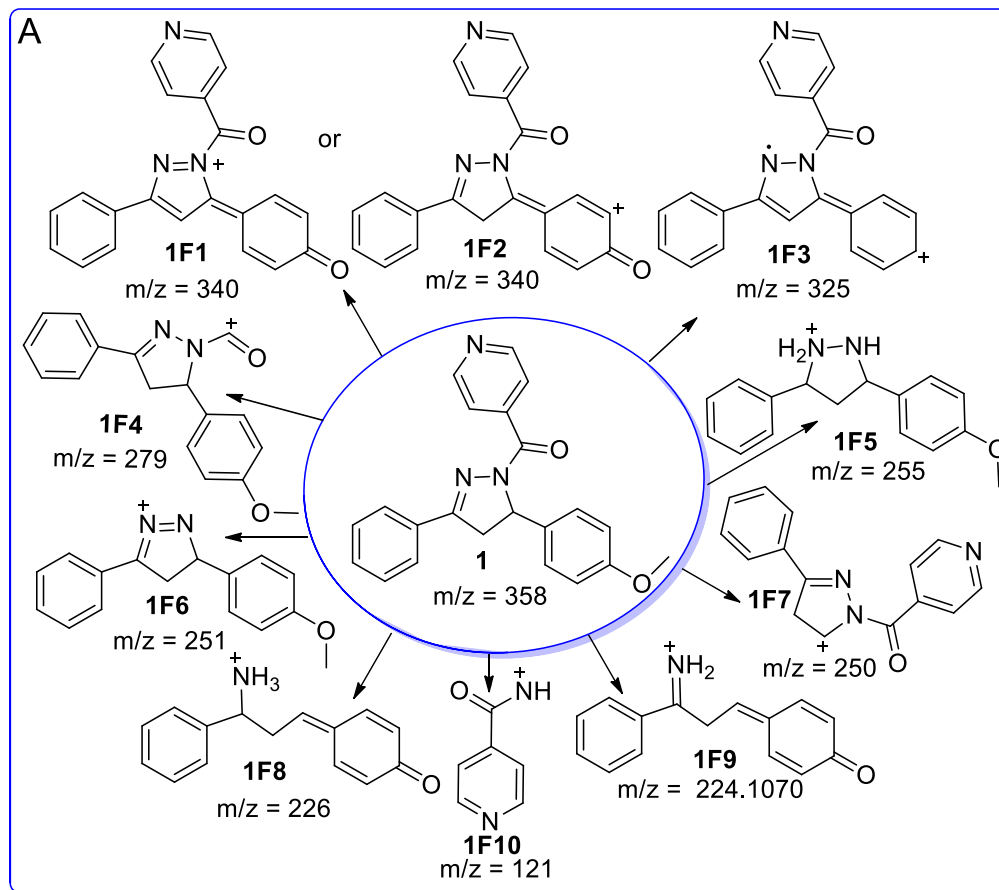

(B) MS² Spectra of 1

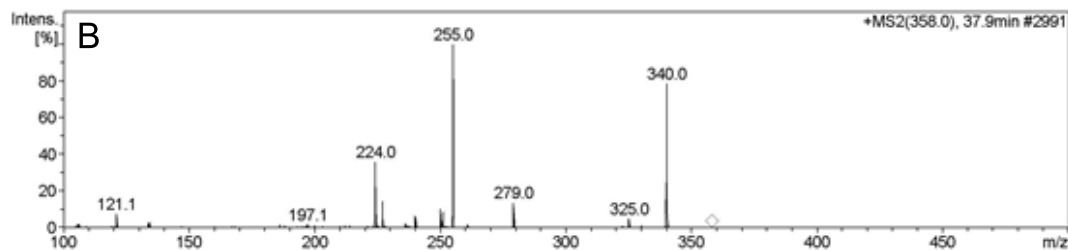

Spectra of standard samples Vs Incubation in RLMs

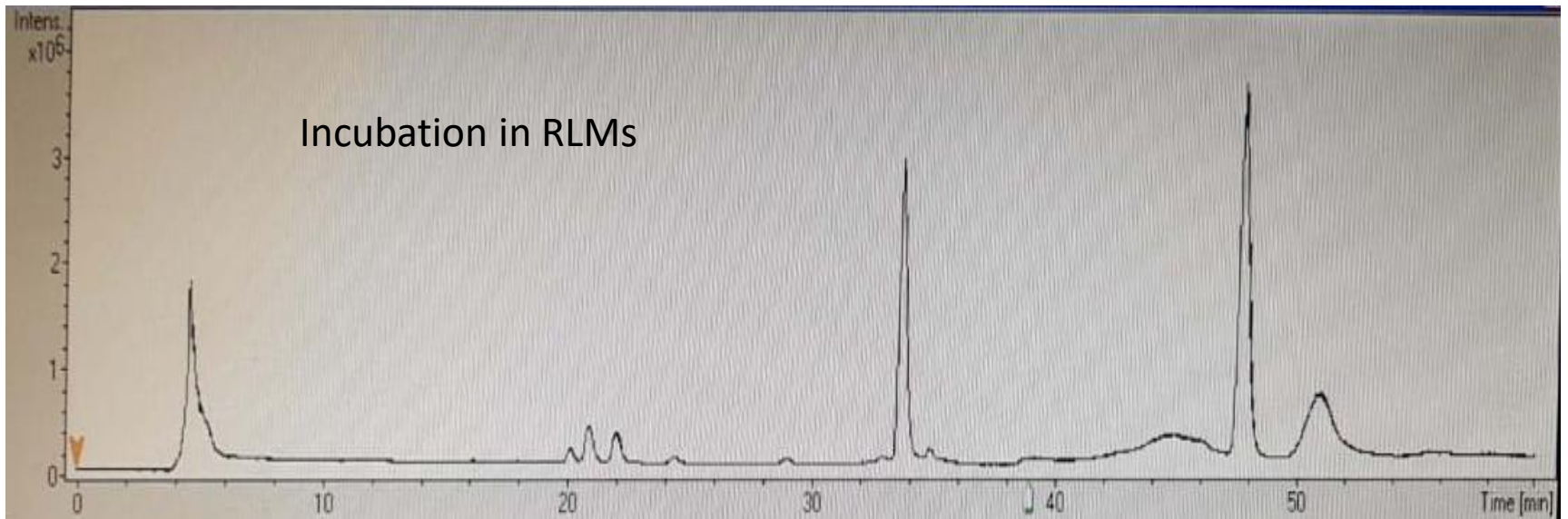
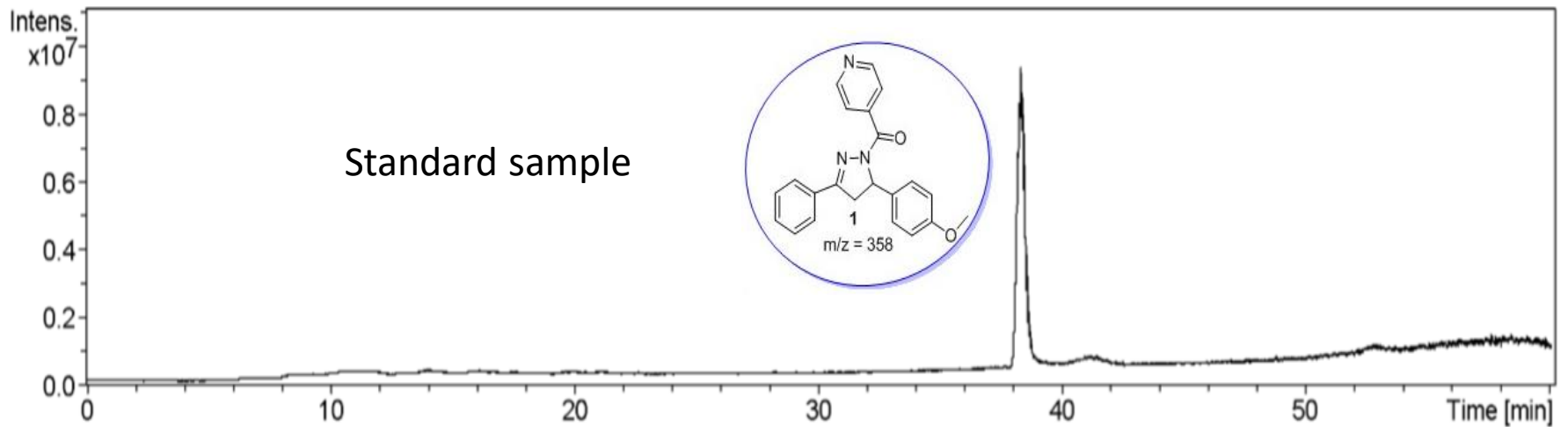

Possible Metabolites of 1

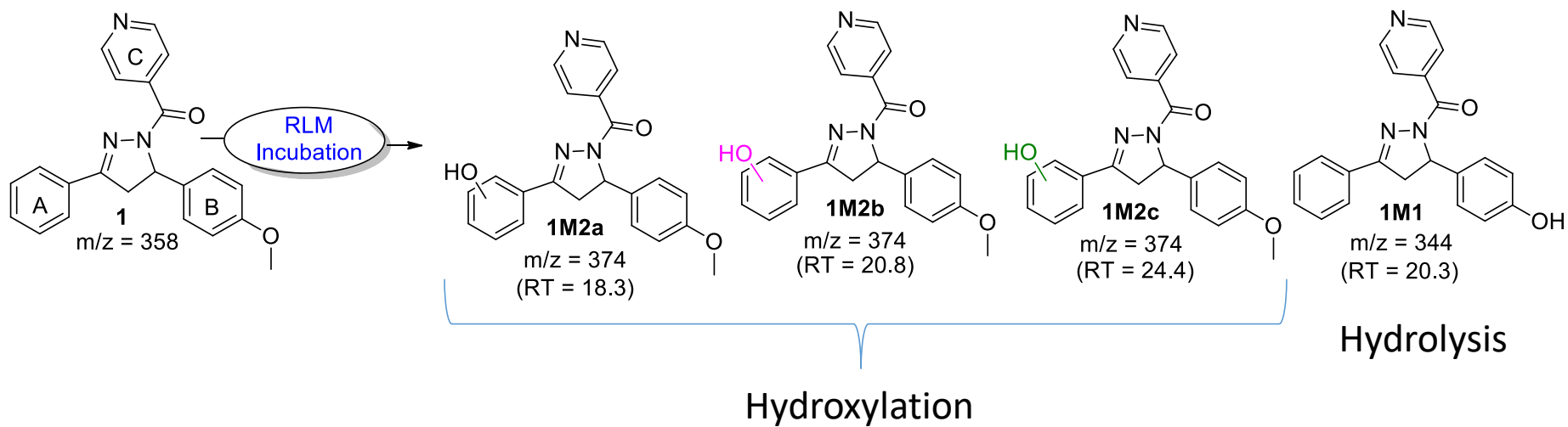

Metabolite 1M1

MS and MS/MS spectra of metabolite **1M1**: (A) EIC spectra of **1M1** at 344; (B) MS spectra of **1M1**; (C) MS² spectra of **1M1**

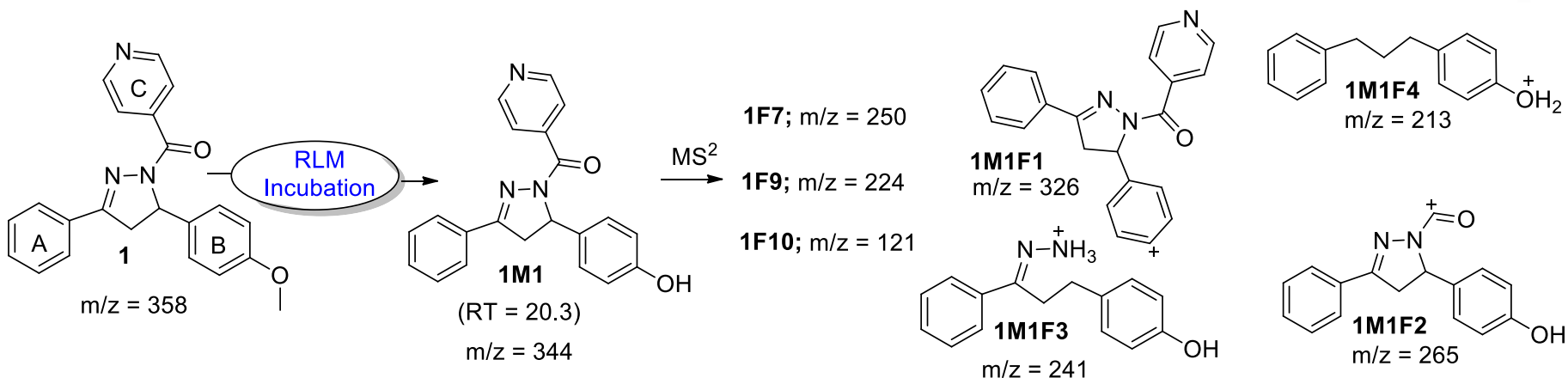
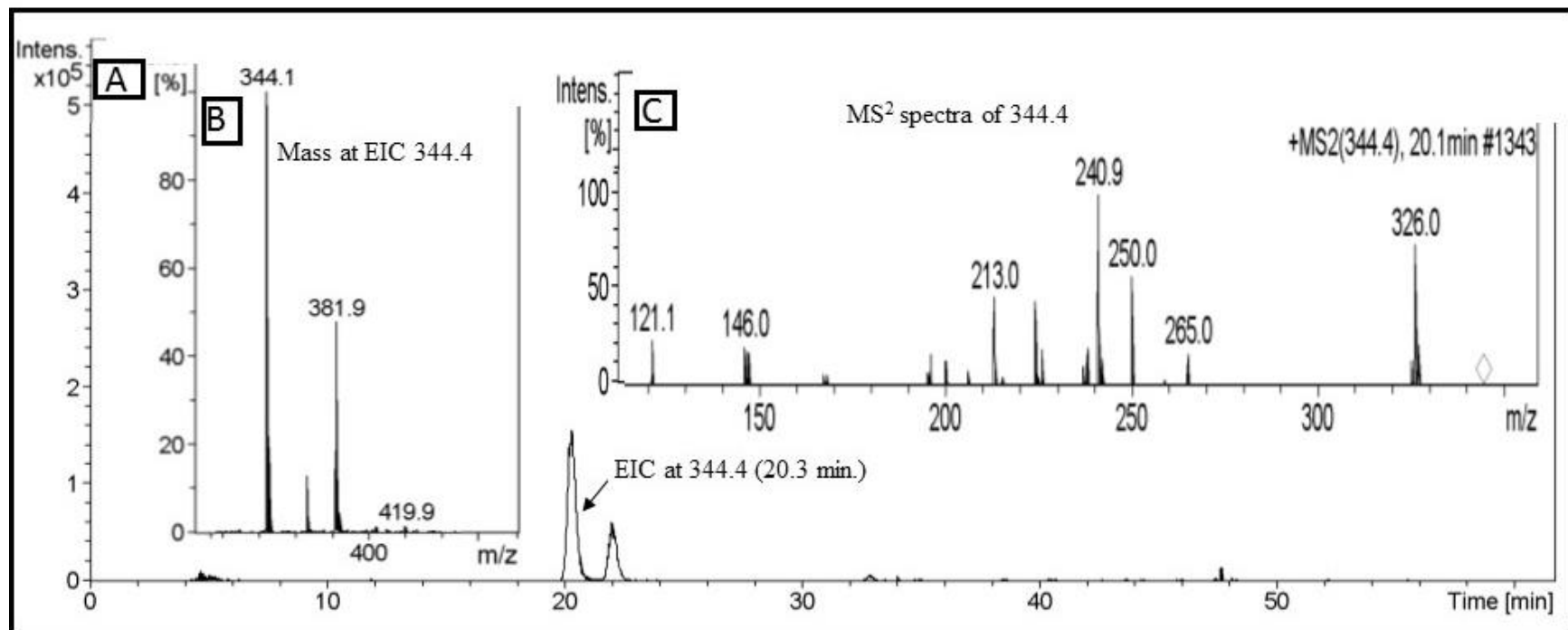

Metabolite 1M2a

MS and MS/MS spectra of metabolite **1M2a**: (A) EIC of **1M2a** at 374; (B) MS spectra of **1M2a**; (C) MS² spectra of **1M2a**

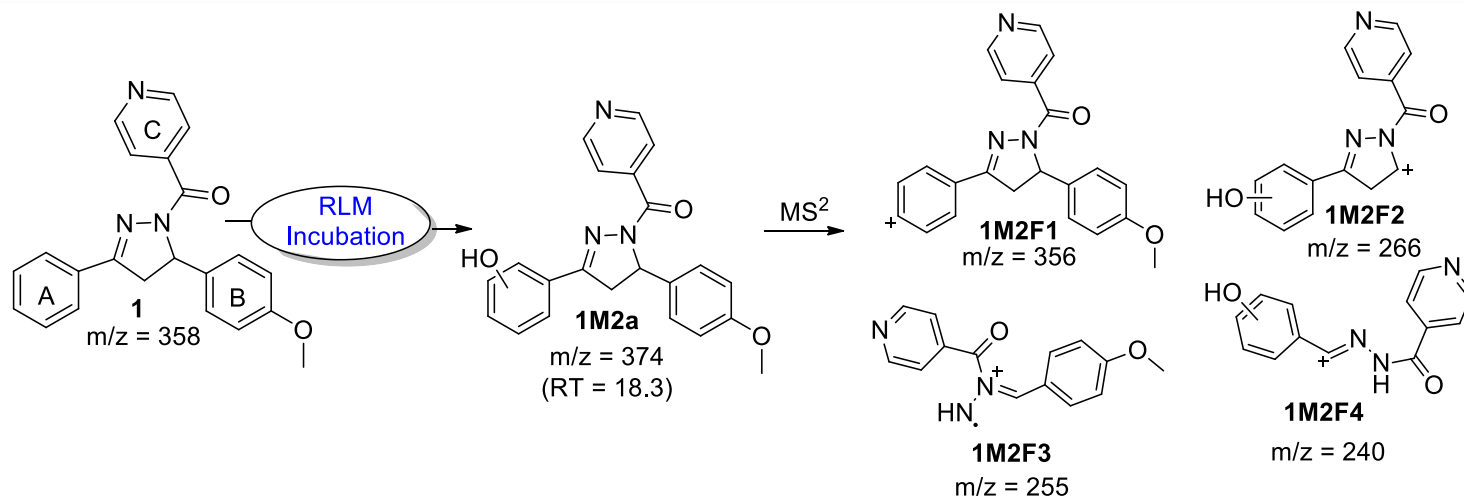
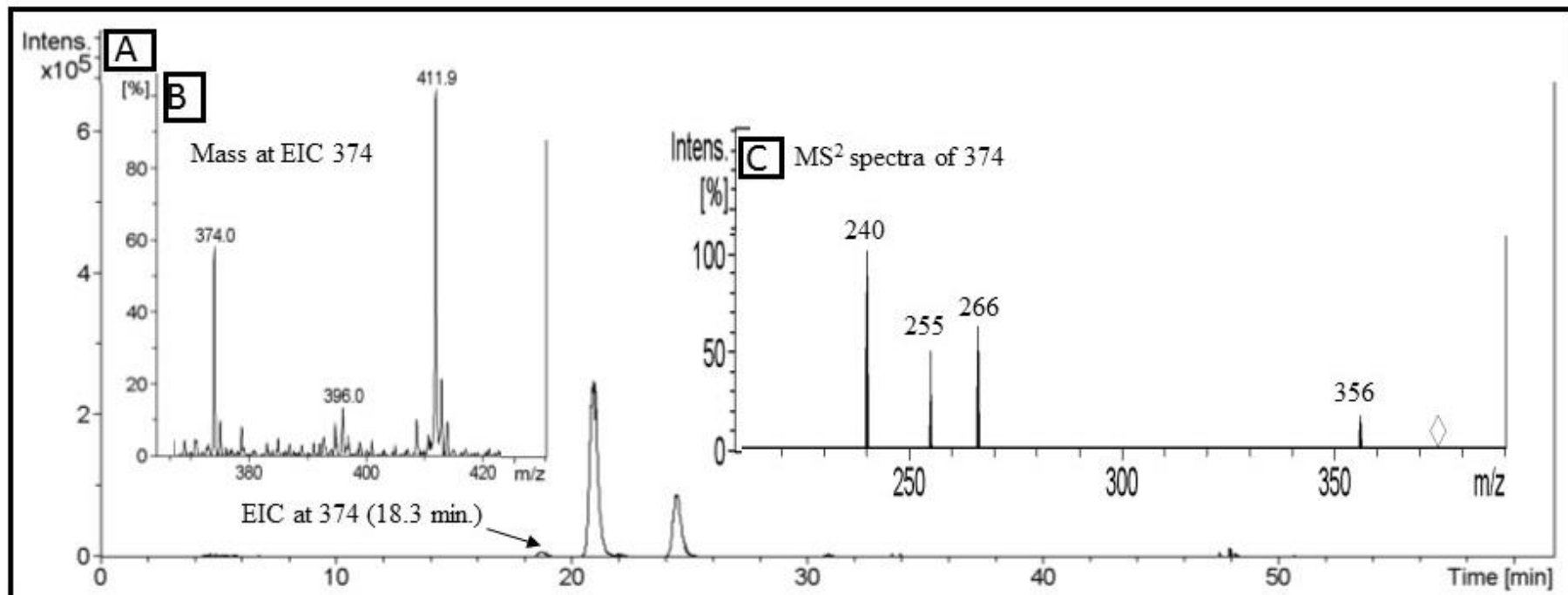

Metabolite 1M2b

MS and MS/MS spectra of metabolite **1M2b**: (A) ESI spectra of **1M2b**; (B) MS spectra of **1M2b**; (C) MS² spectra of **1M2b**

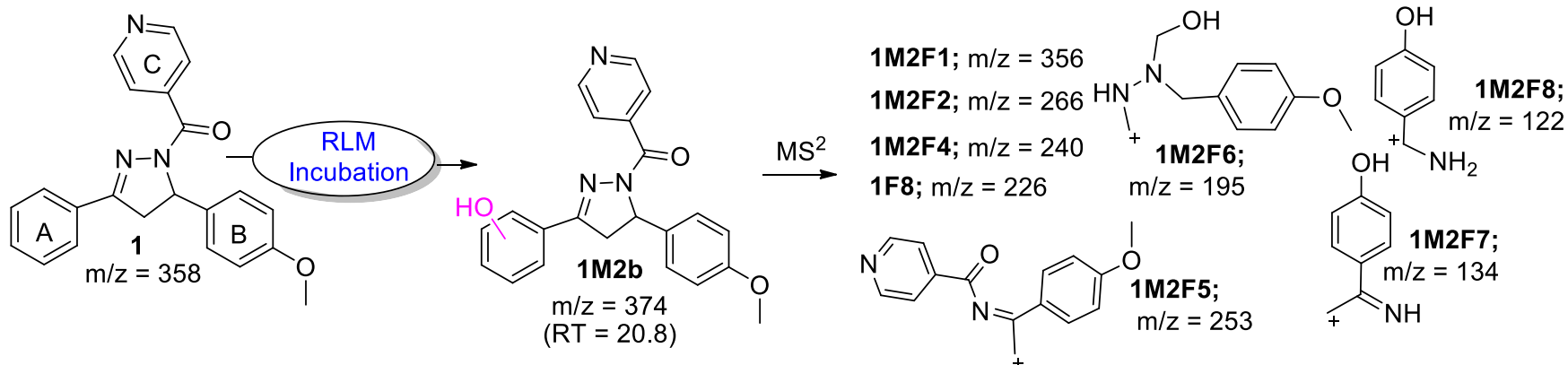
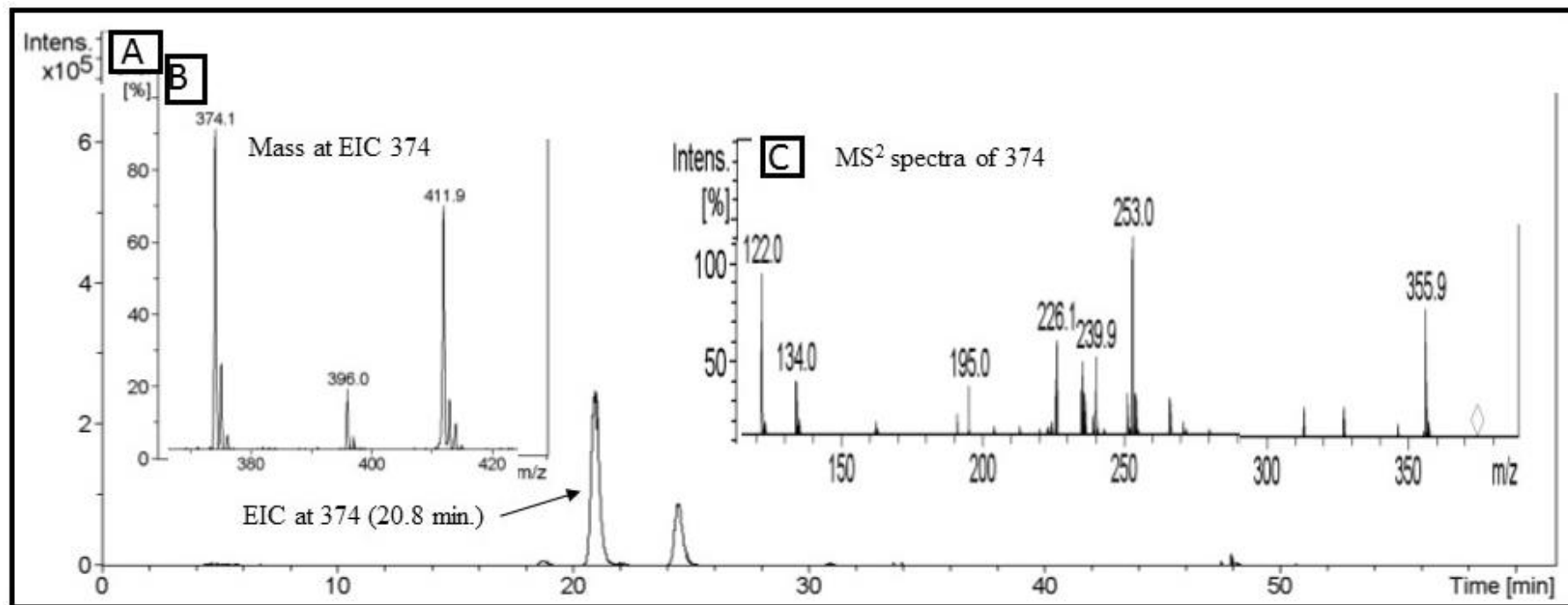

Metabolite 1M2c

MS and MS/MS spectra of metabolite **1M2c**: (A) EIC of **1M2c** at 374; (B) MS spectra of **1M2c**; (C) MS² spectra of **1M2c**

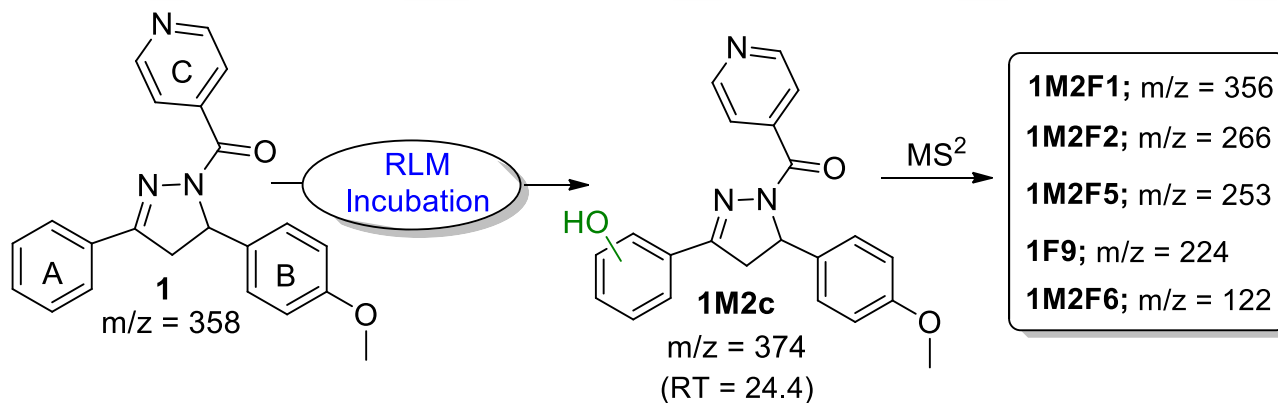
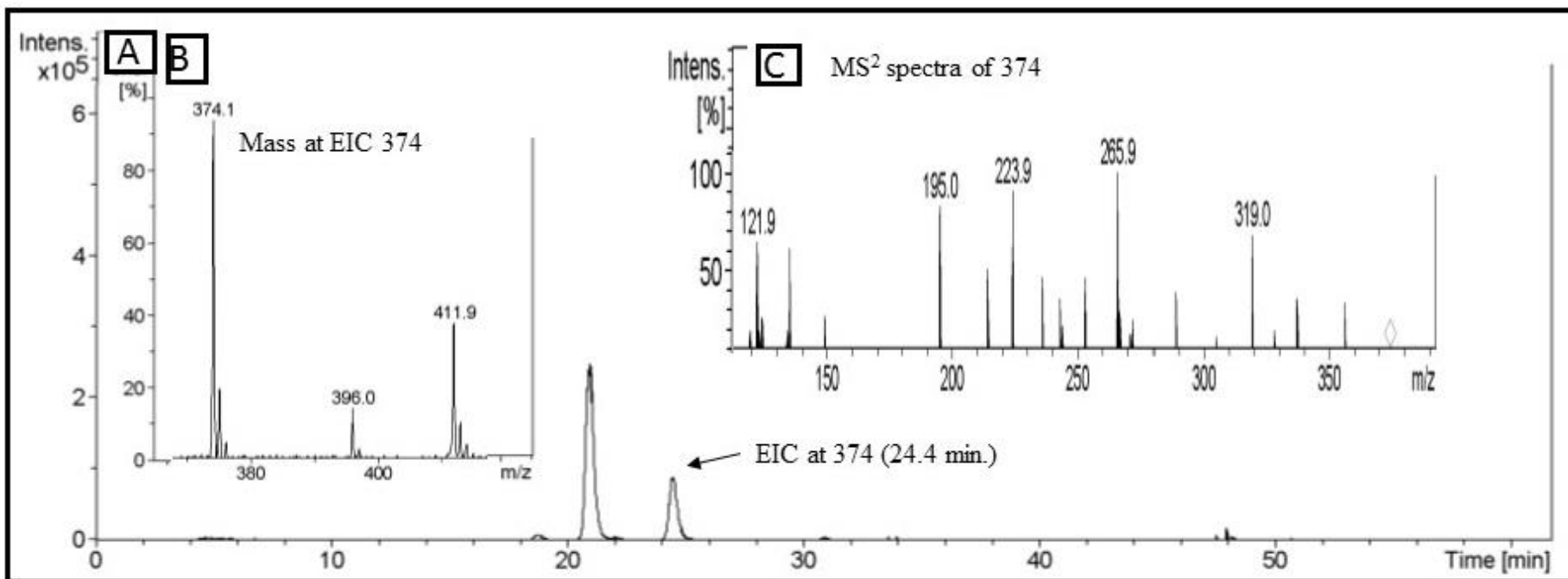

Examination
(multiple question for 5 marks

5th Day

Hands-on Class

1. LC-MS Sample preparation (Standard sample preparation in micromole scale)
2. Buffer solution preparation (formic acid buffer solution as Mobile phase)
3. Isocratic / gradient solvent system method development
4. Setting up: solvent level, injection volume, flow rate, vial position (single /multiple), MS parameters, column position, temperature, etc.
5. Saving method
6. Injection of sample using column
7. Showing chromatogram with mass spectra

6th Day

Hands-on Class

1. LC-MS data analysis
2. TIC / EIC spectra evaluation
3. Structure elucidation of analyzed sample
4. MS/MS spectra run and analysis
5. Structure elucidation using MS/MS data
6. Structure elucidation of metabolites (e.g. demethylation and hydroxylation)

7th Day

Hands-on Class

Method development/saving/run sample/LC-MS data analysis/TIC / EIC spectra evaluation/Structure elucidation of analyzed sample/MS/MS spectra run and analysis'/Structure elucidation using MS/MS data/Structure elucidation of metabolites (e.g. demethylation and hydroxylation) by student

8th Day

Examination
(Final Exam 10 marks