

Chapter 6

Pneumatic Logic Sensors and Actuators

- 6.1** Pneumatic limit, push-button and emergency stop valves
- 6.2** Pneumatic directional pilot control valve
- 6.3** Solenoid actuation directional control valves
- 6.4** Pneumatic directional control valve symbols
- 6.5** Cylinder (cylinders) actuation circuit
 - 6.5.1** Single acting cylinder actuation
 - 6.5.2** Double acting cylinder actuation using pilot valve actuation

Introduction to Pneumatic

- Why pneumatic ?

Pneumatic control system is frequently used in building automatic assembly machines due to low cost compare to hydraulic or electric systems. Also, high response time compare to hydraulic.

- In electric system, system power driven from Voltage (V) and Current (Amp).

- In Pneumatic system, air pressure (bar) equivalent to voltage and air flow (l/min) equivalent to current.

- Hydraulic system is commonly used for heavy duty and heavy load involved, e.g. heavy transportation vehicles.

6.1 Pneumatic limit, push-button and emergency stop valves

- The main structure of the limit valves, push button and emergency stop valves are the same.
- Pneumatic limit valves are the equivalent of mechanical limit switch in its function. Similarly pneumatic push button and emergency stop valves are equivalent of mechanical push button and emergency stop mechanical switches in its functions.
- The main difference between the pneumatic limit valves and the mechanical switches, in the latter, the actuating arm or plunger shifts a so-called directional-control valve rather than electric contacts.
- Same thing is applied for push button and emergency valves.

Limit Switch



Limit Switch with Standard Roller Lever



Limit Valve



6.1 Pneumatic limit, push-button and emergency stop valves

- The main structure of the limit valves, push button and emergency stop valves are the same.
- Pneumatic limit valves are the equivalent of mechanical limit switch in its function. Similarly pneumatic push button and emergency stop valves are equivalent of mechanical push button and emergency stop mechanical switches in its functions.
- The main difference between the pneumatic limit valves and the mechanical switches, in the latter, the actuating arm or plunger shifts a so-called directional-control valve rather than electric contacts.
- Same thing is applied for push button and emergency valves.

Limit Switch



Limit Switch with Standard Roller Lever



Limit Valve



Push button switch



Push button valve

6.1 Pneumatic limit, push-button and emergency stop valves

➤ **3/2 limit valve (meaning 3 connections and 2 positions valve).**

The valve shown as normally closed, so that the outlet line is exhausted to atmosphere when the valve is not actuated.

When the valve is actuated, the roller is depressed against the return spring at the bottom, so that the valve opens and passes supply pressure to the outlet line.

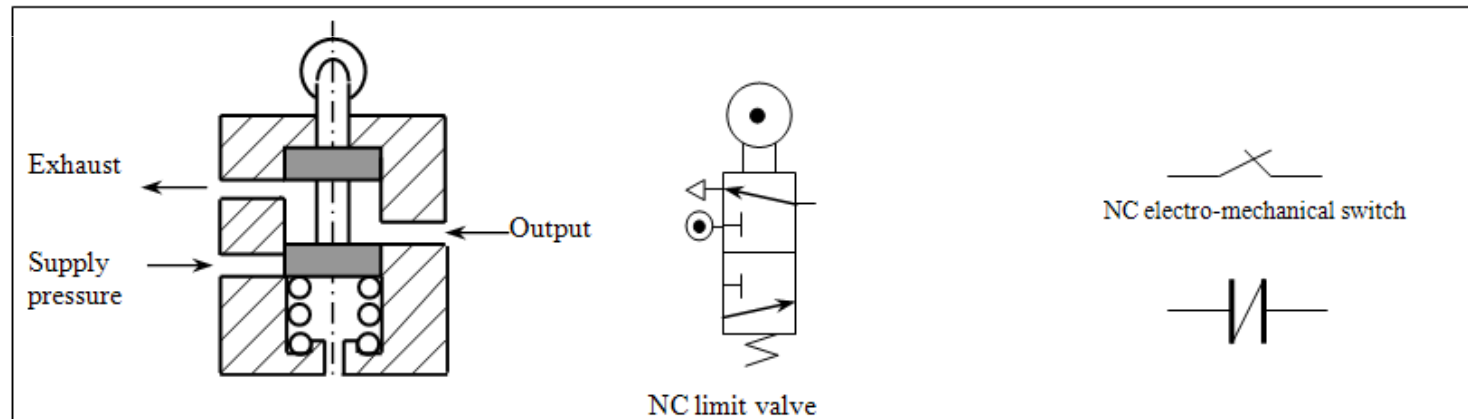
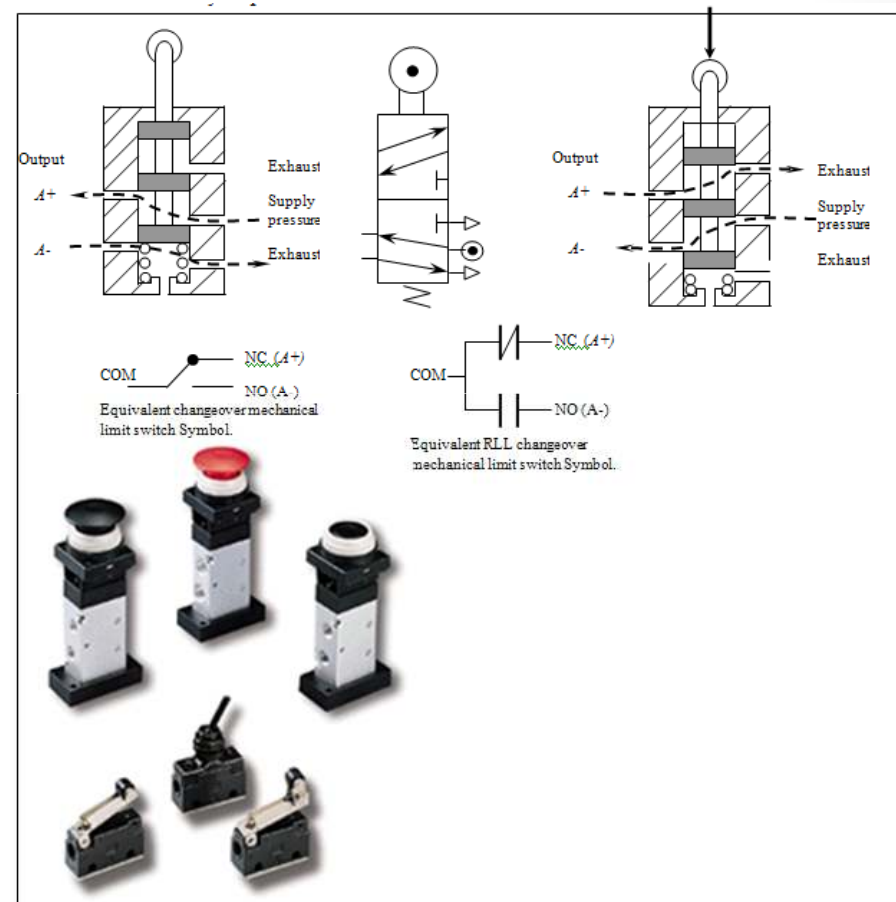

Fig. 6.1 Normally closed limit valve structure, ISO and ANSI symbol and the corresponding electro-mechanical switch symbol.

6.1 Pneumatic limit, push-button and emergency stop valves

➤ 5/2 limit valve (meaning 5 connections and 2 positions valve):

- There are two independent outlet lines, one is normally open and the second normally closed.
- It is analogous to limit mechanical switch with changeover contacts (NO and NC contacts switch).
- For both cases, the limit valve can be used as push-button valve and do the same stated functions.



6.2 Pneumatic directional pilot control valve

➤ Pneumatic directional pilot control valve

- Most directional-control valves are of the spool and sleeve type.
- A 5/2 spool valve (schematically). When the spool position or pilot line has been pressurized by p1 line. Flow line between A & D ports, and B & E posts are passed, while C is blocked.
- If pilot line p2 is pressurized, the spool shifted to the lift with corresponding change in flow paths as illustrated in Fig

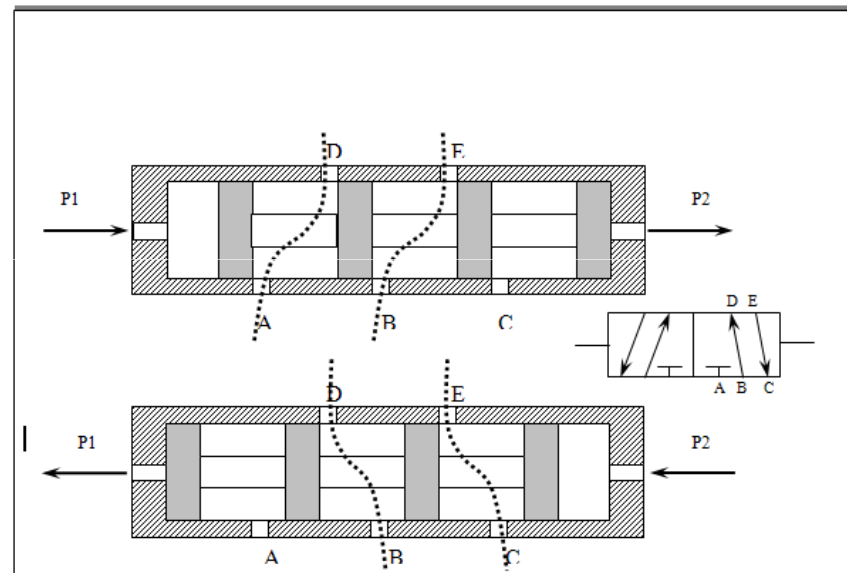
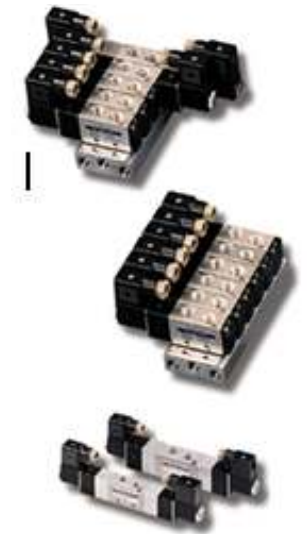
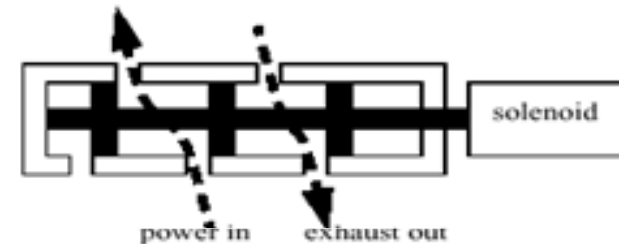

Fig. 6.3 5-ways two positions directional pilot valve; internal structure, and ISO-ANSI valve symbol.

6.3 Solenoid actuation directional control valve

➤ Pneumatic directional solenoid control valve

- The main difference between the solenoid actuation directional control valve and pilot control valve, is the way of displacement of the valve spool. Spool valve displacement is carried out using two pressurized air p_1 and p_2 in case of the pilot control valve.
- While solenoid and spring mechanisms are used to displace the spool valve in case of the solenoid actuation directional valve (or simply solenoid directional valve) . Similarly, solenoid actuation can also be used with 3/2 ways directional valve.



6.4 Pneumatic directional control valve symbols

Most directional-control valves have two or three discrete ports or positions. The international ISO or United States ANSI standard symbols for three connections two position valve, 3/2 valve.

The symbols consist of two rectangles represent the two discrete positions of the valve.

Since the connection tubes are drawn in this case attached to the left rectangle, this means that the valve is presently in the left position.



Fig. 6.5 Illustration of ISO and ANSI symbols of 3/2 and 5/2 ways directional valve.

6.4 Pneumatic directional control valve symbols

Illustrated Examples

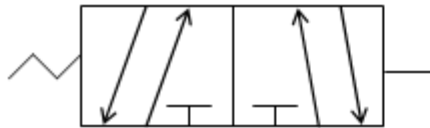

a. Pilot line & return spring (5/2) valve.

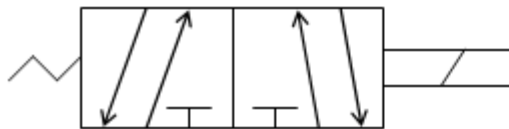

b. Solenoid & return spring (5/2) valve.

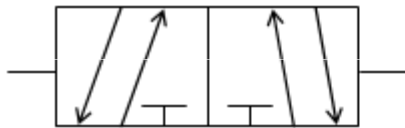

c. Double pilot lines (5/2) valve.

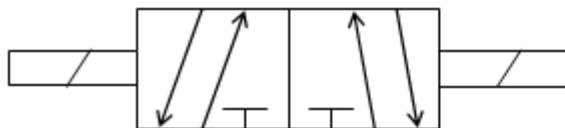

d. Double solenoid (5/2) valve.



e. Double solenoid & return springs (5/3) valve.

6.4 Pneumatic directional control valve symbols

Additional Pneumatic Symbols

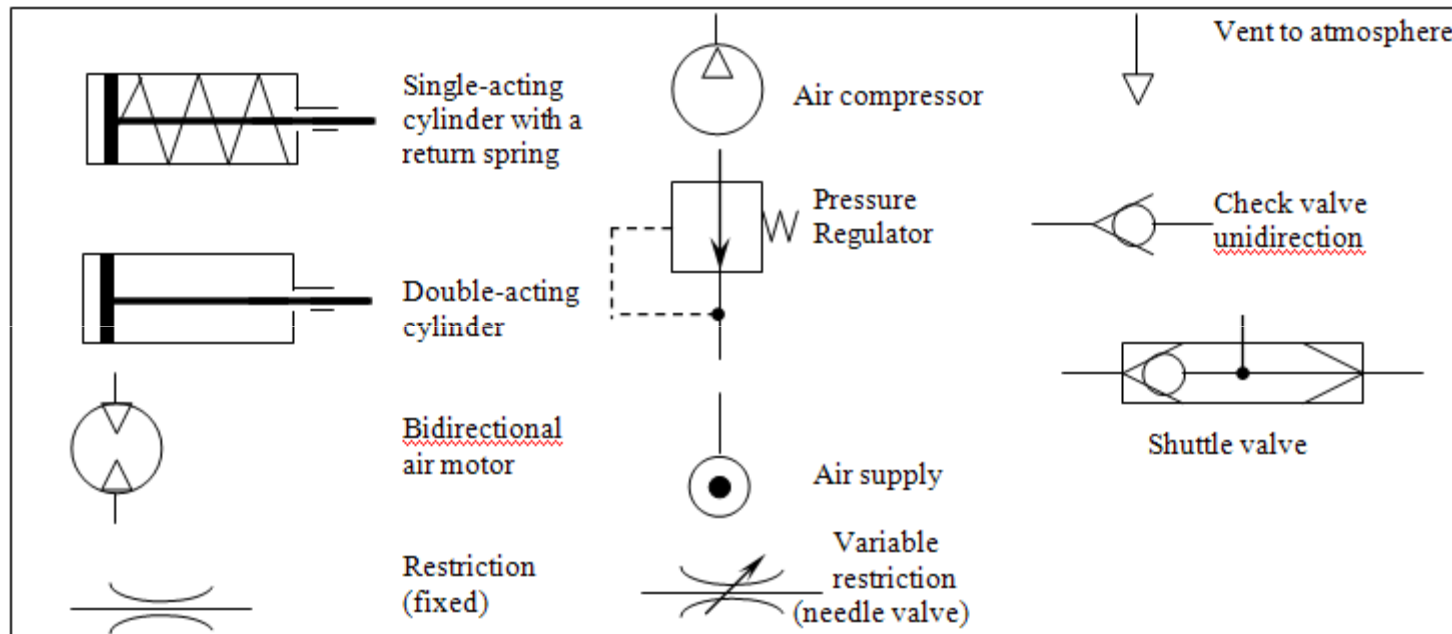
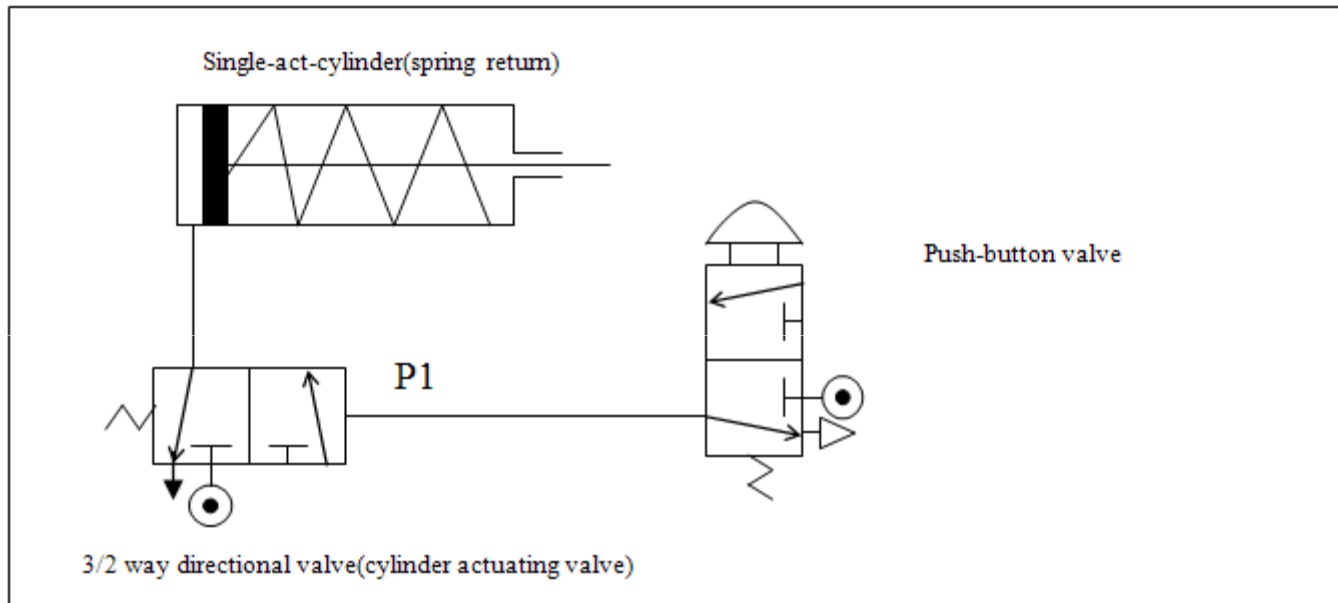

Fig. 6.8 Additional pneumatic symbols.

6.5 Simple Pneumatic Networks

6.5.1 Single Acting Cylinder Actuation Network



6.5 Simple Pneumatic Networks

6.5.2 Double Acting Cylinder Network using Pilot line valves

Machine sequence :

START, A+,A- .

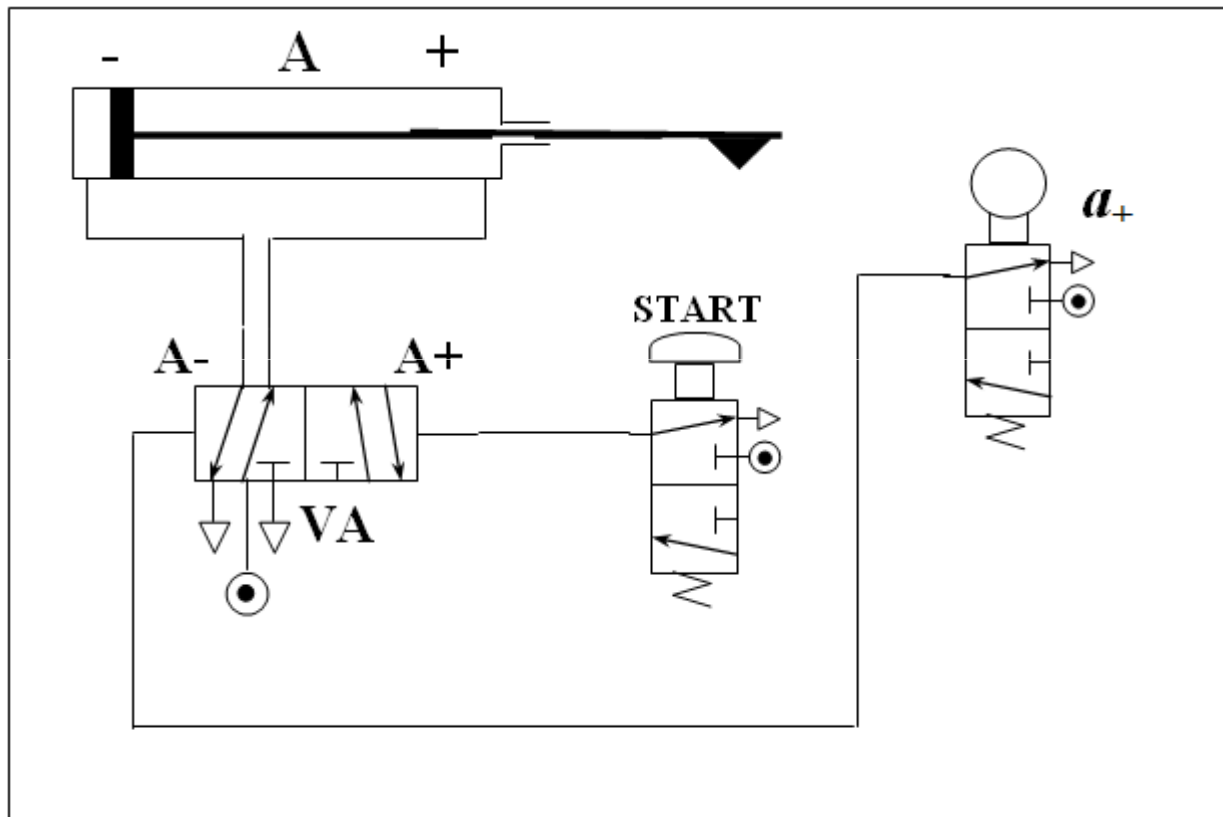

Problems

- 6.1) “Two-hand safety circuit”, is a pneumatic circuit used for actuating dangerous equipment such as punch press, it has two push button valves mounted sufficiently apart so that both cannot be reached with one hand. Both push buttons must be pressed simultaneously to actuate the press (or double-acting cylinder). Hence, this will force the operator to withdraw both hands from the dangerous area before the press descends. Draw pneumatic circuit to actuates double acting cylinder using three pneumatic valves; the first and the second valves are two 3/2 push button valves, and the third valve VA is 5/2 directional valve with one pilot line and return spring ?

Ans)

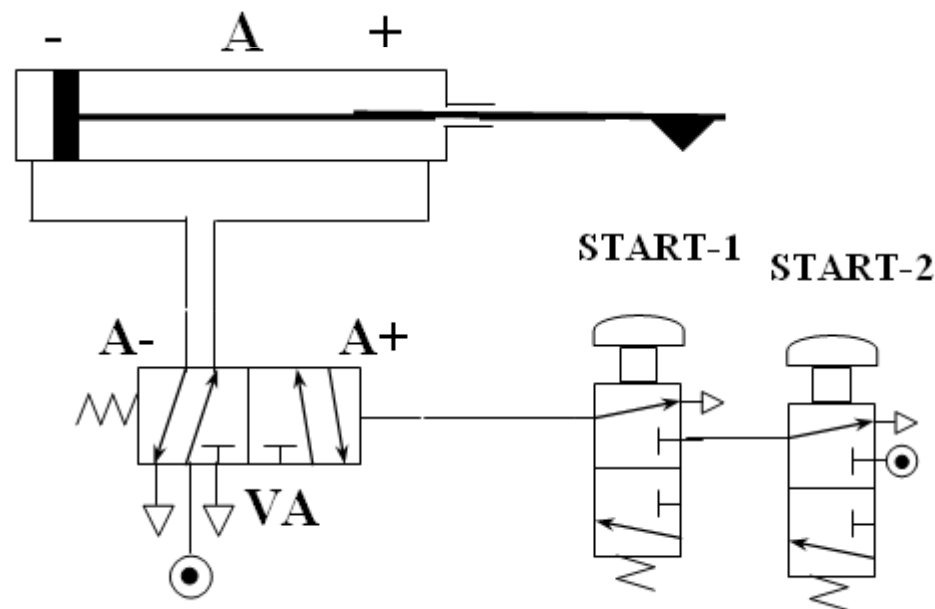

Problems

6.2) Draw the ISO or ANSI symbol of 3/2 limit valve with normally open design structure?

Ans)

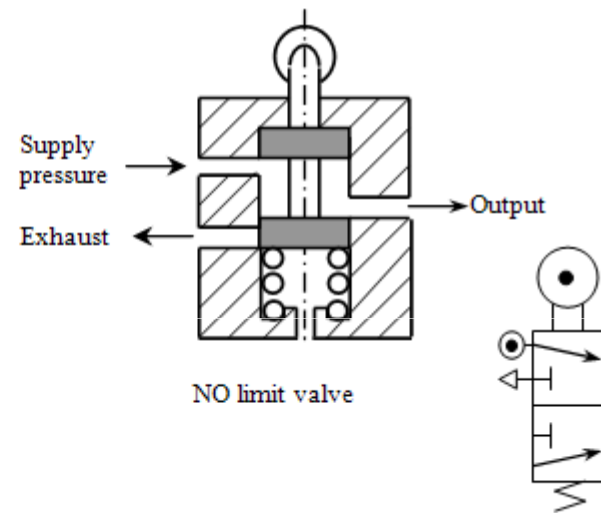
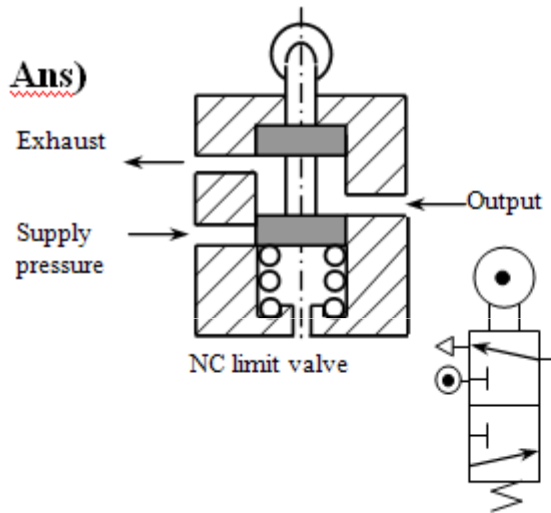

Problems

- 6.3) Draw a pneumatic circuit to drive two double acting cylinders (A and B) using two 5/2 pilot type valves, push button 3/2 valve and two 3/2 limit valves using the following control sequence : $START, A^+, B^+, \begin{pmatrix} A^- \\ B^- \end{pmatrix}$.

Ans)

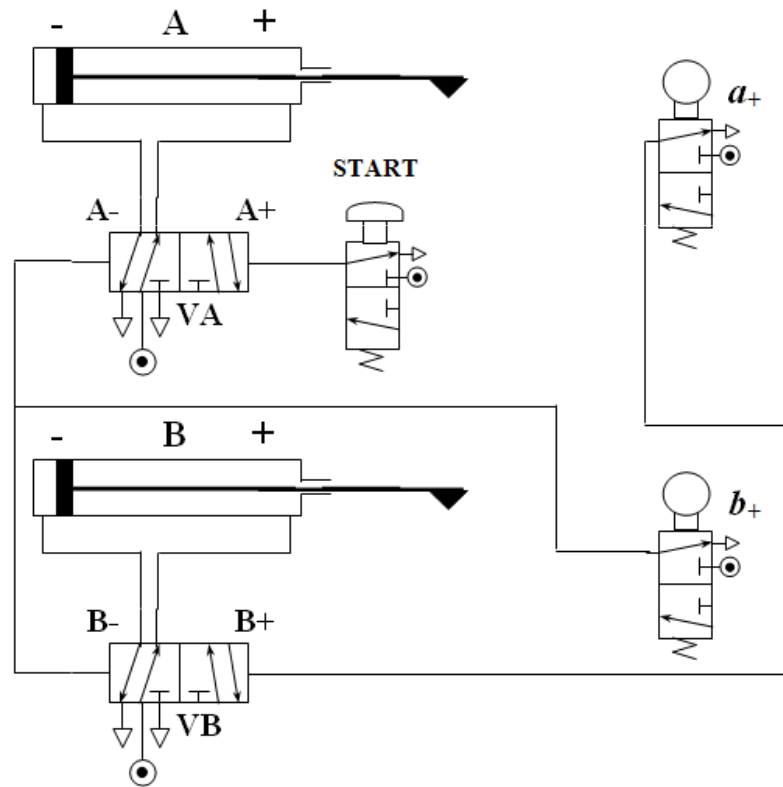

Problems

6.4) Develop the pneumatic network for R/S Flip-Flop using Pilot 5/2 valve and 2 push-button valves 3/2 type with spring return, draw the pneumatic network circuit ?

6.5) Develop the pneumatic network circuit using for the following pneumatic machine sequence:

$$START, \left(\begin{array}{c} A^+ \\ B^+ \end{array} \right), \left(\begin{array}{c} A^- \\ B^- \end{array} \right).$$

6.6) Develop a pneumatic network to drive a single acting cylinder using one or both two START push buttons, 3/2 type?

6.7) Develop a pneumatic network circuit to run the following pneumatic machine sequence:

$$START, A^+, \left(\begin{array}{c} B^+ \\ C^+ \end{array} \right), \left(\begin{array}{c} A^- \\ B^- \\ C^- \end{array} \right)$$

6.8) Develop pneumatic network circuit for AND, OR and NOT gates?

Problems

- 6.9) Develop a pneumatic network circuit to move pneumatic motor clockwise and counterclockwise directions manually. The motor direction setting achieved by actuating 5x2 manual bush-button direction valve, while motor rotation setting activated by actuating 3x2 push-button valve with spring return.

