

QUESTIONS

- How can the average value of a current be zero and yet the square root of the average squared current not be zero?
- What is the time average of the “square-wave” potential shown in Figure Q33.2? What is its rms voltage?

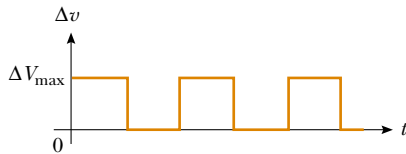

Figure Q33.2

- Do AC ammeters and voltmeters read maximum, rms, or average values?
- In the clearest terms you can, explain the statement, “The voltage across an inductor leads the current by 90° .”
- Some fluorescent lights flicker on and off 120 times every second. Explain what causes this. Why can’t you see it happening?
- Why does a capacitor act as a short circuit at high frequencies? Why does it act as an open circuit at low frequencies?
- Explain how the mnemonic “ELI the ICE man” can be used to recall whether current leads voltage or voltage leads current in RLC circuits. Note that E represents emf \mathcal{E} .
- Why is the sum of the maximum voltages across each of the elements in a series RLC circuit usually greater than the maximum applied voltage? Doesn’t this violate Kirchhoff’s loop rule?
- Does the phase angle depend on frequency? What is the phase angle when the inductive reactance equals the capacitive reactance?
- In a series RLC circuit, what is the possible range of values for the phase angle?
- If the frequency is doubled in a series RLC circuit, what happens to the resistance, the inductive reactance, and the capacitive reactance?
- Explain why the average power delivered to an RLC circuit by the source depends on the phase angle between the current and applied voltage.
- As shown in Figure 7.5a, a person pulls a vacuum cleaner at speed v across a horizontal floor, exerting on it a force of magnitude F directed upward at an angle θ with the horizontal. At what rate is the person doing work on the cleaner? State as completely as you can the analogy between power in this situation and in an electric circuit.
- A particular experiment requires a beam of light of very stable intensity. Why would an AC voltage be unsuitable for powering the light source?
- Do some research to answer these questions: Who invented the metal detector? Why? Did it work?
- What is the advantage of transmitting power at high voltages?
- What determines the maximum voltage that can be used on a transmission line?
- Will a transformer operate if a battery is used for the input voltage across the primary? Explain.
- Someone argues that high-voltage power lines actually waste more energy. He points out that the rate at which internal energy is produced in a wire is given by $(\Delta V)^2/R$, where R is the resistance of the wire. Therefore, the higher the voltage, the higher the energy waste. What if anything is wrong with his argument?
- Explain how the quality factor is related to the response characteristics of a radio receiver. Which variable most strongly influences the quality factor?
- Why are the primary and secondary coils of a transformer wrapped on an iron core that passes through both coils?
- With reference to Figure Q33.22, explain why the capacitor prevents a DC signal from passing between A and B, yet allows an AC signal to pass from A to B. (The circuits are said to be capacitively coupled.)

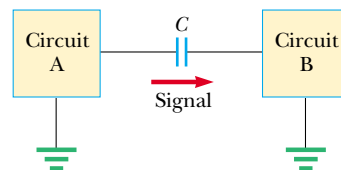





Figure Q33.22

PROBLEMS

1, 2, 3 = straightforward, intermediate, challenging □ = full solution available in the *Student Solutions Manual and Study Guide*

 = coached solution with hints available at <http://www.pse6.com>  = computer useful in solving problem

 = paired numerical and symbolic problems

Note: Assume all AC voltages and currents are sinusoidal, unless stated otherwise.

Section 33.1 AC Sources

Section 33.2 Resistors in an AC Circuit

- The rms output voltage of an AC source is 200 V and the operating frequency is 100 Hz. Write the equation giving the output voltage as a function of time.
- (a) What is the resistance of a lightbulb that uses an average power of 75.0 W when connected to a 60.0-Hz power source having a maximum voltage of 170 V? (b) **What If?** What is the resistance of a 100-W bulb?
- An AC power supply produces a maximum voltage $\Delta V_{\max} = 100$ V. This power supply is connected to a 24.0- Ω resistor, and the current and resistor voltage are measured with an ideal AC ammeter and voltmeter, as shown in Figure P33.3. What does each meter read? Note that an ideal ammeter has zero resistance and that an ideal voltmeter has infinite resistance.

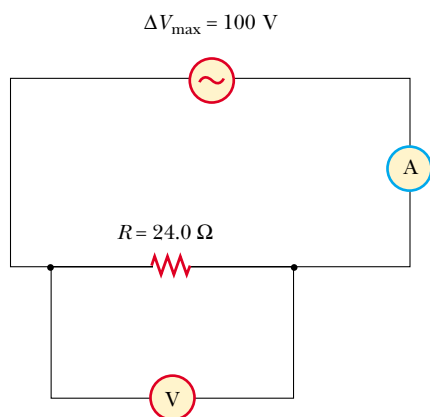

Figure P33.3

- In the simple AC circuit shown in Figure 33.2, $R = 70.0 \Omega$ and $\Delta v = \Delta V_{\max} \sin \omega t$. (a) If $\Delta v_R = 0.250 \Delta V_{\max}$ for the first time at $t = 0.010$ s, what is the angular frequency of the source? (b) What is the next value of t for which $\Delta v_R = 0.250 \Delta V_{\max}$?
- The current in the circuit shown in Figure 33.2 equals 60.0% of the peak current at $t = 7.00$ ms. What is the smallest frequency of the source that gives this current?
- Figure P33.6 shows three lamps connected to a 120-V AC (rms) household supply voltage. Lamps 1 and 2 have 150-W bulbs; lamp 3 has a 100-W bulb. Find the rms current and resistance of each bulb.

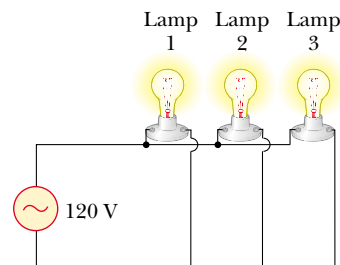

Figure P33.6

- An audio amplifier, represented by the AC source and resistor in Figure P33.7, delivers to the speaker alternating voltage at audio frequencies. If the source voltage has an amplitude of 15.0 V, $R = 8.20 \Omega$, and the speaker is equivalent to a resistance of 10.4 Ω , what is the time-averaged power transferred to it?

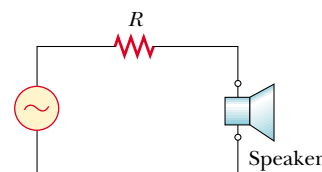

Figure P33.7

Section 33.3 Inductors in an AC Circuit

- An inductor is connected to a 20.0-Hz power supply that produces a 50.0-V rms voltage. What inductance is needed to keep the instantaneous current in the circuit below 80.0 mA?
- In a purely inductive AC circuit, as shown in Figure 33.6, $\Delta V_{\max} = 100$ V. (a) The maximum current is 7.50 A at 50.0 Hz. Calculate the inductance L . (b) **What If?** At what angular frequency ω is the maximum current 2.50 A?
- An inductor has a 54.0- Ω reactance at 60.0 Hz. What is the maximum current if this inductor is connected to a 50.0-Hz source that produces a 100-V rms voltage?
- For the circuit shown in Figure 33.6, $\Delta V_{\max} = 80.0$ V, $\omega = 65.0\pi$ rad/s, and $L = 70.0$ mH. Calculate the current in the inductor at $t = 15.5$ ms.
- A 20.0-mH inductor is connected to a standard electrical outlet ($\Delta V_{\text{rms}} = 120$ V; $f = 60.0$ Hz). Determine the energy stored in the inductor at $t = (1/180)$ s, assuming that this energy is zero at $t = 0$.
- Review problem.** Determine the maximum magnetic flux through an inductor connected to a standard electrical outlet ($\Delta V_{\text{rms}} = 120$ V, $f = 60.0$ Hz).

Section 33.4 Capacitors in an AC Circuit

14. (a) For what frequencies does a $22.0\text{-}\mu\text{F}$ capacitor have a reactance below $175\ \Omega$? (b) **What If?** Over this same frequency range, what is the reactance of a $44.0\text{-}\mu\text{F}$ capacitor?
15. What is the maximum current in a $2.20\text{-}\mu\text{F}$ capacitor when it is connected across (a) a North American electrical outlet having $\Delta V_{\text{rms}} = 120\ \text{V}$, $f = 60.0\ \text{Hz}$, and (b) **What If?** a European electrical outlet having $\Delta V_{\text{rms}} = 240\ \text{V}$, $f = 50.0\ \text{Hz}$?
16. A capacitor C is connected to a power supply that operates at a frequency f and produces an rms voltage ΔV . What is the maximum charge that appears on either of the capacitor plates?
17. What maximum current is delivered by an AC source with $\Delta V_{\text{max}} = 48.0\ \text{V}$ and $f = 90.0\ \text{Hz}$ when connected across a $3.70\text{-}\mu\text{F}$ capacitor?
18. A 1.00-mF capacitor is connected to a standard electrical outlet ($\Delta V_{\text{rms}} = 120\ \text{V}$; $f = 60.0\ \text{Hz}$). Determine the current in the capacitor at $t = (1/180)\ \text{s}$, assuming that at $t = 0$, the energy stored in the capacitor is zero.

Section 33.5 The RLC Series Circuit

19. An inductor ($L = 400\ \text{mH}$), a capacitor ($C = 4.43\ \mu\text{F}$), and a resistor ($R = 500\ \Omega$) are connected in series. A 50.0-Hz AC source produces a peak current of $250\ \text{mA}$ in the circuit. (a) Calculate the required peak voltage ΔV_{max} . (b) Determine the phase angle by which the current leads or lags the applied voltage.
20. At what frequency does the inductive reactance of a $57.0\text{-}\mu\text{H}$ inductor equal the capacitive reactance of a $57.0\text{-}\mu\text{F}$ capacitor?
21. A series AC circuit contains the following components: $R = 150\ \Omega$, $L = 250\ \text{mH}$, $C = 2.00\ \mu\text{F}$ and a source with $\Delta V_{\text{max}} = 210\ \text{V}$ operating at $50.0\ \text{Hz}$. Calculate the (a) inductive reactance, (b) capacitive reactance, (c) impedance, (d) maximum current, and (e) phase angle between current and source voltage.
22. A sinusoidal voltage $\Delta v(t) = (40.0\ \text{V}) \sin(100t)$ is applied to a series RLC circuit with $L = 160\ \text{mH}$, $C = 99.0\ \mu\text{F}$, and $R = 68.0\ \Omega$. (a) What is the impedance of the circuit? (b) What is the maximum current? (c) Determine the numerical values for I_{max} , ω , and ϕ in the equation $i(t) = I_{\text{max}} \sin(\omega t - \phi)$.
23. An RLC circuit consists of a $150\text{-}\Omega$ resistor, a $21.0\text{-}\mu\text{F}$ capacitor, and a 460-mH inductor, connected in series with a 120-V , 60.0-Hz power supply. (a) What is the phase angle between the current and the applied voltage? (b) Which reaches its maximum earlier, the current or the voltage?
24. Four circuit elements—a capacitor, an inductor, a resistor, and an AC source—are connected together in various ways. First the capacitor is connected to the source, and the rms current is found to be $25.1\ \text{mA}$. The capacitor is disconnected and discharged, and then connected in series with the resistor and the source, making the rms current $15.7\ \text{mA}$. The circuit is disconnected and the capacitor discharged. The capacitor is then connected in

series with the inductor and the source, making the rms current $68.2\ \text{mA}$. After the circuit is disconnected and the capacitor discharged, all four circuit elements are connected together in a series loop. What is the rms current in the circuit?

25. A person is working near the secondary of a transformer, as shown in Figure P33.25. The primary voltage is $120\ \text{V}$ at $60.0\ \text{Hz}$. The capacitance C_s , which is the stray capacitance between the hand and the secondary winding, is $20.0\ \text{pF}$. Assuming the person has a body resistance to ground $R_b = 50.0\ \text{k}\Omega$, determine the rms voltage across the body. (*Suggestion:* Redraw the circuit with the secondary of the transformer as a simple AC source.)

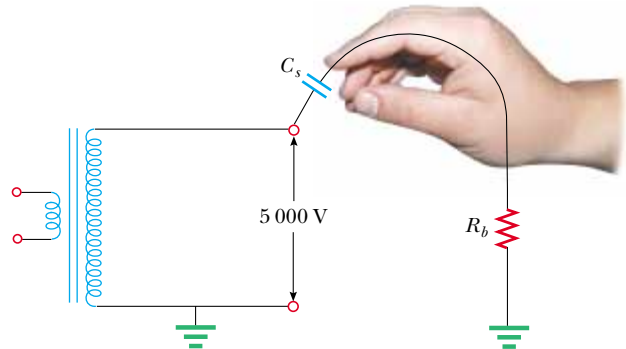

Figure P33.25

26. An AC source with $\Delta V_{\text{max}} = 150\ \text{V}$ and $f = 50.0\ \text{Hz}$ is connected between points a and d in Figure P33.26. Calculate the maximum voltages between points (a) a and b , (b) b and c , (c) c and d , and (d) b and d .

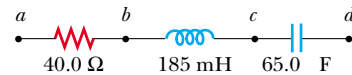

Figure P33.26 Problems 26 and 68.

27. Draw to scale a phasor diagram showing Z , X_L , X_C , and ϕ for an AC series circuit for which $R = 300\ \Omega$, $C = 11.0\ \mu\text{F}$, $L = 0.200\ \text{H}$, and $f = (500/\pi)\ \text{Hz}$.
28. In an RLC series circuit that includes a source of alternating current operating at fixed frequency and voltage, the resistance R is equal to the inductive reactance. If the plate separation of the capacitor is reduced to half of its original value, the current in the circuit doubles. Find the initial capacitive reactance in terms of R .
29. A coil of resistance $35.0\ \Omega$ and inductance $20.5\ \text{H}$ is in series with a capacitor and a 200-V (rms), 100-Hz source. The rms current in the circuit is $4.00\ \text{A}$. (a) Calculate the capacitance in the circuit. (b) What is ΔV_{rms} across the coil?

Section 33.6 Power in an AC Circuit

30. The voltage source in Figure P33.30 has an output of $\Delta V_{\text{rms}} = 100\ \text{V}$ at an angular frequency of $\omega = 1000\ \text{rad/s}$. Determine (a) the current in the circuit and (b) the power supplied by the source. (c) Show that the power delivered to the resistor is equal to the power supplied by the source.

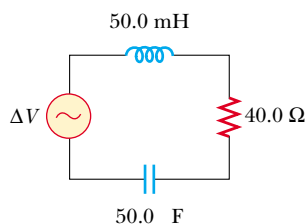

Figure P33.30

31. An AC voltage of the form $\Delta v = (100 \text{ V}) \sin(1000t)$ is applied to a series RLC circuit. Assume the resistance is 400Ω , the capacitance is $5.00 \mu\text{F}$, and the inductance is 0.500 H . Find the average power delivered to the circuit.
32. A series RLC circuit has a resistance of 45.0Ω and an impedance of 75.0Ω . What average power is delivered to this circuit when $\Delta V_{\text{rms}} = 210 \text{ V}$?
33. In a certain series RLC circuit, $I_{\text{rms}} = 9.00 \text{ A}$, $\Delta V_{\text{rms}} = 180 \text{ V}$, and the current leads the voltage by 37.0° . (a) What is the total resistance of the circuit? (b) Calculate the reactance of the circuit ($X_L - X_C$).
34. Suppose you manage a factory that uses many electric motors. The motors create a large inductive load to the electric power line, as well as a resistive load. The electric company builds an extra-heavy distribution line to supply you with a component of current that is 90° out of phase with the voltage, as well as with current in phase with the voltage. The electric company charges you an extra fee for “reactive volt-amps,” in addition to the amount you pay for the energy you use. You can avoid the extra fee by installing a capacitor between the power line and your factory. The following problem models this solution.
- In an RL circuit, a 120-V (rms), 60.0-Hz source is in series with a 25.0-mH inductor and a $20.0\text{-}\Omega$ resistor. What are (a) the rms current and (b) the power factor? (c) What capacitor must be added in series to make the power factor 1? (d) To what value can the supply voltage be reduced, if the power supplied is to be the same as before the capacitor was installed?
35. Suppose power \mathcal{P} is to be transmitted over a distance d at a voltage ΔV with only 1.00% loss. Copper wire of what diameter should be used for each of the two conductors of the transmission line? Assume the current density in the conductors is uniform.
36. A diode is a device that allows current to be carried in only one direction (the direction indicated by the arrowhead in its circuit symbol). Find in terms of ΔV and R the average power delivered to the diode circuit of Figure P33.36.

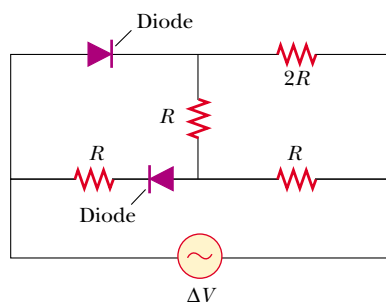

Figure P33.36

Section 33.7 Resonance in a Series RLC Circuit

37. An RLC circuit is used in a radio to tune into an FM station broadcasting at 99.7 MHz . The resistance in the circuit is 12.0Ω , and the inductance is $1.40 \mu\text{H}$. What capacitance should be used?
38. The tuning circuit of an AM radio contains an LC combination. The inductance is 0.200 mH , and the capacitor is variable, so that the circuit can resonate at any frequency between 550 kHz and 1650 kHz . Find the range of values required for C .
39. A radar transmitter contains an LC circuit oscillating at $1.00 \times 10^{10} \text{ Hz}$. (a) What capacitance will resonate with a one-turn loop of inductance 400 pH at this frequency? (b) If the capacitor has square parallel plates separated by 1.00 mm of air, what should the edge length of the plates be? (c) What is the common reactance of the loop and capacitor at resonance?
40. A series RLC circuit has components with following values: $L = 20.0 \text{ mH}$, $C = 100 \text{ nF}$, $R = 20.0 \Omega$, and $\Delta V_{\text{max}} = 100 \text{ V}$, with $\Delta v = \Delta V_{\text{max}} \sin \omega t$. Find (a) the resonant frequency, (b) the amplitude of the current at the resonant frequency, (c) the Q of the circuit, and (d) the amplitude of the voltage across the inductor at resonance.

41. A $10.0\text{-}\Omega$ resistor, 10.0-mH inductor, and $100\text{-}\mu\text{F}$ capacitor are connected in series to a 50.0-V (rms) source having variable frequency. Find the energy that is delivered to the circuit during one period if the operating frequency is twice the resonance frequency.
42. A resistor R , inductor L , and capacitor C are connected in series to an AC source of rms voltage ΔV and variable frequency. Find the energy that is delivered to the circuit during one period if the operating frequency is twice the resonance frequency.
43. Compute the quality factor for the circuits described in Problems 22 and 23. Which circuit has the sharper resonance?

Section 33.8 The Transformer and Power Transmission

44. A step-down transformer is used for recharging the batteries of portable devices such as tape players. The turns ratio inside the transformer is $13:1$ and it is used with 120-V (rms) household service. If a particular ideal transformer draws 0.350 A from the house outlet, what are (a) the voltage and (b) the current supplied to a tape player from the transformer? (c) How much power is delivered?
45. A transformer has $N_1 = 350$ turns and $N_2 = 2000$ turns. If the input voltage is $\Delta v(t) = (170 \text{ V}) \cos \omega t$, what rms voltage is developed across the secondary coil?
46. A step-up transformer is designed to have an output voltage of 2200 V (rms) when the primary is connected across a 110-V (rms) source. (a) If the primary winding has 80 turns, how many turns are required on the secondary? (b) If a load resistor across the secondary draws a current of 1.50 A , what is the current in the primary, assuming ideal conditions? (c) **What If?** If the transformer actually

has an efficiency of 95.0%, what is the current in the primary when the secondary current is 1.20 A?

47. In the transformer shown in Figure P33.47, the load resistor is $50.0\ \Omega$. The turns ratio $N_1:N_2$ is 5:2, and the source voltage is 80.0 V (rms). If a voltmeter across the load measures 25.0 V (rms), what is the source resistance R_s ?

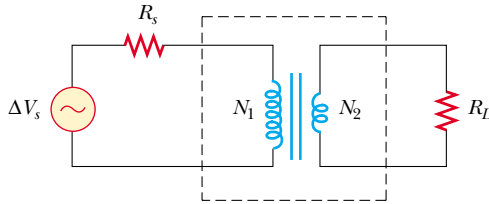

Figure P33.47

48. The secondary voltage of an ignition transformer in a furnace is 10.0 kV. When the primary operates at an rms voltage of 120 V, the primary impedance is $24.0\ \Omega$ and the transformer is 90.0% efficient. (a) What turns ratio is required? What are (b) the current in the secondary and (c) the impedance in the secondary?
49. A transmission line that has a resistance per unit length of $4.50 \times 10^{-4}\ \Omega/\text{m}$ is to be used to transmit 5.00 MW over 400 miles ($6.44 \times 10^5\ \text{m}$). The output voltage of the generator is 4.50 kV. (a) What is the line loss if a transformer is used to step up the voltage to 500 kV? (b) What fraction of the input power is lost to the line under these circumstances? (c) **What If?** What difficulties would be encountered in attempting to transmit the 5.00 MW at the generator voltage of 4.50 kV?

Section 33.9 Rectifiers and Filters

50. One particular plug-in power supply for a radio looks similar to the one shown in Figure 33.23 and is marked with the following information: Input 120 V AC 8 W Output 9 V DC 300 mA. Assume that these values are accurate to two digits. (a) Find the energy efficiency of the device when the radio is operating. (b) At what rate does the device produce wasted energy when the radio is operating? (c) Suppose that the input power to the transformer is 8.0 W when the radio is switched off and that energy costs \$0.135/kWh from the electric company. Find the cost of having six such transformers around the house, plugged in for thirty-one days.
51. Consider the filter circuit shown in Figure 33.25a. (a) Show that the ratio of the output voltage to the input voltage is

$$\frac{\Delta V_{\text{out}}}{\Delta V_{\text{in}}} = \frac{R}{\sqrt{R^2 + \left(\frac{1}{\omega C}\right)^2}}$$

(b) What value does this ratio approach as the frequency decreases toward zero? What value does this ratio approach as the frequency increases without limit? (c) At what frequency is the ratio equal to one half?

52. Consider the filter circuit shown in Figure 33.26a. (a) Show that the ratio of the output voltage to the input

voltage is

$$\frac{\Delta V_{\text{out}}}{\Delta V_{\text{in}}} = \frac{1/\omega C}{\sqrt{R^2 + \left(\frac{1}{\omega C}\right)^2}}$$

(b) What value does this ratio approach as the frequency decreases toward zero? What value does this ratio approach as the frequency increases without limit? (c) At what frequency is the ratio equal to one half?

53.  The RC high-pass filter shown in Figure 33.25 has a resistance $R = 0.500\ \Omega$. (a) What capacitance gives an output signal that has half the amplitude of a 300-Hz input signal? (b) What is the ratio $(\Delta V_{\text{out}}/\Delta V_{\text{in}})$ for a 600-Hz signal? You may use the result of Problem 51.
54. The RC low-pass filter shown in Figure 33.26 has a resistance $R = 90.0\ \Omega$ and a capacitance $C = 8.00\ \text{nF}$. Calculate the ratio $(\Delta V_{\text{out}}/\Delta V_{\text{in}})$ for an input frequency of (a) 600 Hz and (b) 600 kHz. You may use the result of Problem 52.
55. The resistor in Figure P33.55 represents the midrange speaker in a three-speaker system. Assume its resistance to be constant at $8.00\ \Omega$. The source represents an audio amplifier producing signals of uniform amplitude $\Delta V_{\text{in}} = 10.0\ \text{V}$ at all audio frequencies. The inductor and capacitor are to function as a bandpass filter with $\Delta V_{\text{out}}/\Delta V_{\text{in}} = 1/2$ at 200 Hz and at 4 000 Hz. (a) Determine the required values of L and C . (b) Find the maximum value of the ratio $\Delta V_{\text{out}}/\Delta V_{\text{in}}$. (c) Find the frequency f_0 at which the ratio has its maximum value. (d) Find the phase shift between ΔV_{in} and ΔV_{out} at 200 Hz, at f_0 , and at 4 000 Hz. (e) Find the average power transferred to the speaker at 200 Hz, at f_0 , and at 4 000 Hz. (f) Treating the filter as a resonant circuit, find its quality factor.

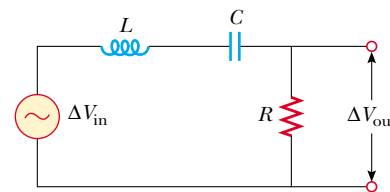

Figure P33.55

Additional Problems

56. Show that the rms value for the sawtooth voltage shown in Figure P33.56 is $\Delta V_{\text{max}}/\sqrt{3}$.

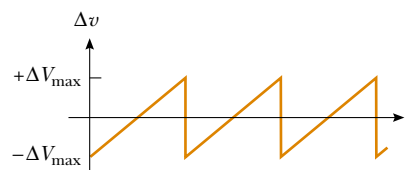



Figure P33.56

57.  A series RLC circuit consists of an $8.00\text{-}\Omega$ resistor, a $5.00\text{-}\mu\text{F}$ capacitor, and a 50.0-mH inductor. A variable

frequency source applies an emf of 400 V (rms) across the combination. Determine the power delivered to the circuit when the frequency is equal to half the resonance frequency.

58. A capacitor, a coil, and two resistors of equal resistance are arranged in an AC circuit, as shown in Figure P33.58. An AC source provides an emf of 20.0 V (rms) at a frequency of 60.0 Hz. When the double-throw switch S is open, as shown in the figure, the rms current is 183 mA. When the switch is closed in position 1, the rms current is 298 mA. When the switch is closed in position 2, the rms current is 137 mA. Determine the values of R , C , and L . Is more than one set of values possible?

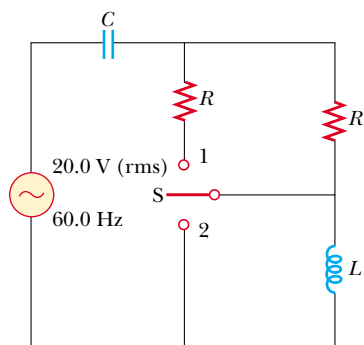

Figure P33.58

59. To determine the inductance of a coil used in a research project, a student first connects the coil to a 12.0-V battery and measures a current of 0.630 A. The student then connects the coil to a 24.0-V (rms), 60.0-Hz generator and measures an rms current of 0.570 A. What is the inductance?
60. **Review problem.** One insulated conductor from a household extension cord has mass per length 19.0 g/m. A section of this conductor is held under tension between two clamps. A subsection is located in a region of magnetic field of magnitude 15.3 mT perpendicular to the length of the cord. The wire carries an AC current of 9.00 A at 60.0 Hz. Determine some combination of values for the distance between the clamps and the tension in the cord so that the cord can vibrate in the lowest-frequency standing-wave vibrational state.
61. In Figure P33.61, find the rms current delivered by the 45.0-V (rms) power supply when (a) the frequency is very large and (b) the frequency is very small.

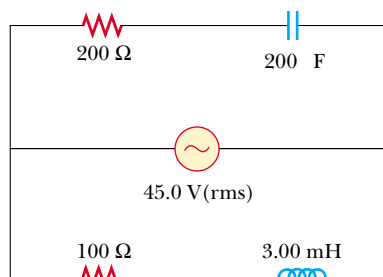

Figure P33.61

62. In the circuit shown in Figure P33.62, assume that all parameters except for C are given. (a) Find the current as a function of time. (b) Find the power delivered to the circuit. (c) Find the current as a function of time after *only* switch 1 is opened. (d) After switch 2 is *also* opened, the current and voltage are in phase. Find the capacitance C . (e) Find the impedance of the circuit when both switches are open. (f) Find the maximum energy stored in the capacitor during oscillations. (g) Find the maximum energy stored in the inductor during oscillations. (h) Now the frequency of the voltage source is doubled. Find the phase difference between the current and the voltage. (i) Find the frequency that makes the inductive reactance half the capacitive reactance.

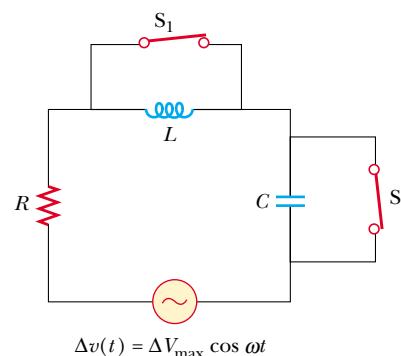

Figure P33.62

63. An 80.0- Ω resistor and a 200-mH inductor are connected in *parallel* across a 100-V (rms), 60.0-Hz source. (a) What is the rms current in the resistor? (b) By what angle does the total current lead or lag behind the voltage?
64. Make an order-of-magnitude estimate of the electric current that the electric company delivers to a town (Figure P33.64) from a remote generating station. State the data you measure or estimate. If you wish, you may consider a suburban bedroom community of 20 000 people.



Figure P33.64

65. Consider a series RLC circuit having the following circuit parameters: $R = 200 \Omega$, $L = 663 \text{ mH}$, and $C = 26.5 \mu\text{F}$. The applied voltage has an amplitude of 50.0 V and a frequency of 60.0 Hz. Find the following amplitudes: (a) The current I_{max} , including its phase constant ϕ relative to the applied voltage Δv , (b) the voltage ΔV_R

across the resistor and its phase relative to the current, (c) the voltage ΔV_C across the capacitor and its phase relative to the current, and (d) the voltage ΔV_L across the inductor and its phase relative to the current.

66. A voltage $\Delta v = (100 \text{ V}) \sin \omega t$ (in SI units) is applied across a series combination of a 2.00-H inductor, a 10.0- μF capacitor, and a 10.0- Ω resistor. (a) Determine the angular frequency ω_0 at which the power delivered to the resistor is a maximum. (b) Calculate the power delivered at that frequency. (c) Determine the two angular frequencies ω_1 and ω_2 at which the power is half the maximum value. [The Q of the circuit is $\omega_0/(\omega_2 - \omega_1)$.]

67. **Impedance matching.** Example 28.2 showed that maximum power is transferred when the internal resistance of a DC source is equal to the resistance of the load. A transformer may be used to provide maximum power transfer between two AC circuits that have different impedances Z_1 and Z_2 , where 1 and 2 are subscripts and the Z 's are italic (as in the centered equation). (a) Show that the ratio of turns N_1/N_2 needed to meet this condition is

$$\frac{N_1}{N_2} = \sqrt{\frac{Z_1}{Z_2}}$$

(b) Suppose you want to use a transformer as an impedance-matching device between an audio amplifier that has an output impedance of 8.00 k Ω and a speaker that has an input impedance of 8.00 Ω . What should your N_1/N_2 ratio be?

68. A power supply with $\Delta V_{\text{rms}} = 120 \text{ V}$ is connected between points a and d in Figure P33.26. At what frequency will it deliver a power of 250 W?
69. Figure P33.69a shows a parallel RLC circuit, and the corresponding phasor diagram is given in Figure P33.69b. The instantaneous voltages (and rms voltages) across each of the three circuit elements are the same, and each is in

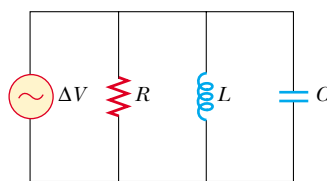

(a)

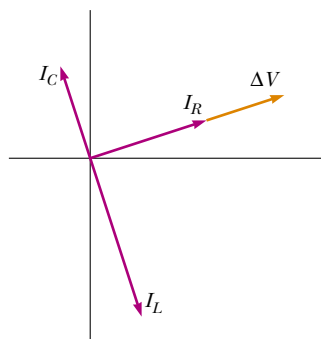

(b)

Figure P33.69

phase with the current through the resistor. The currents in C and L lead or lag behind the current in the resistor, as shown in Figure P33.69b. (a) Show that the rms current delivered by the source is

$$I_{\text{rms}} = \Delta V_{\text{rms}} \left[\frac{1}{R^2} + \left(\omega C - \frac{1}{\omega L} \right)^2 \right]^{1/2}$$

(b) Show that the phase angle ϕ between ΔV_{rms} and I_{rms} is

$$\tan \phi = R \left(\frac{1}{X_C} - \frac{1}{X_L} \right)$$

70. An 80.0- Ω resistor, a 200-mH inductor, and a 0.150- μF capacitor are connected *in parallel* across a 120-V (rms) source operating at 374 rad/s. (a) What is the resonant frequency of the circuit? (b) Calculate the rms current in the resistor, inductor, and capacitor. (c) What rms current is delivered by the source? (d) Is the current leading or lagging behind the voltage? By what angle?
71. A series RLC circuit is operating at 2 000 Hz. At this frequency, $X_L = X_C = 1 884 \Omega$. The resistance of the circuit is 40.0 Ω . (a) Prepare a table showing the values of X_L , X_C , and Z for $f = 300, 600, 800, 1 000, 1 500, 2 000, 3 000, 4 000, 6 000,$ and 10 000 Hz. (b) Plot on the same set of axes X_L , X_C , and Z as a function of $\ln f$.
72. A series RLC circuit in which $R = 1.00 \Omega$, $L = 1.00 \text{ mH}$, and $C = 1.00 \text{ nF}$ is connected to an AC source delivering 1.00 V (rms). Make a precise graph of the power delivered to the circuit as a function of the frequency and verify that the full width of the resonance peak at half-maximum is $R/2\pi L$.
73. Suppose the high-pass filter shown in Figure 33.25 has $R = 1 000 \Omega$ and $C = 0.050 0 \mu\text{F}$. (a) At what frequency does $\Delta V_{\text{out}}/\Delta V_{\text{in}} = \frac{1}{2}$? (b) Plot $\log_{10}(\Delta V_{\text{out}}/\Delta V_{\text{in}})$ versus $\log_{10}(f)$ over the frequency range from 1 Hz to 1 MHz. (This log-log plot of gain versus frequency is known as a *Bode plot*.)

Answers to Quick Quizzes

- 33.1 (a). The phasor in part (a) has the largest projection onto the vertical axis.
- 33.2 (b). The phasor in part (b) has the smallest-magnitude projection onto the vertical axis.
- 33.3 (c). The average power is proportional to the rms current, which, as Figure 33.5 shows, is nonzero even though the average current is zero. Condition (a) is valid only for an open circuit, and conditions (b) and (d) can not be true because $i_{\text{av}} = 0$ if the source is sinusoidal.
- 33.4 (b). For low frequencies, the reactance of the inductor is small so that the current is large. Most of the voltage from the source is across the bulb, so the power delivered to it is large.
- 33.5 (a). For high frequencies, the reactance of the capacitor is small so that the current is large. Most of the voltage from the source is across the bulb, so the power delivered to it is large.
- 33.6 (b). For low frequencies, the reactance of the capacitor is large so that very little current exists in the capacitor

branch. The reactance of the inductor is small so that current exists in the inductor branch and the lightbulb glows. As the frequency increases, the inductive reactance increases and the capacitive reactance decreases. At high frequencies, more current exists in the capacitor branch than the inductor branch and the lightbulb glows more dimly.

- 33.7** (a) $X_L < X_C$. (b) $X_L = X_C$. (c) $X_L > X_C$.
- 33.8** (c). The cosine of $-\phi$ is the same as that of $+\phi$, so the $\cos \phi$ factor in Equation 33.31 is the same for both frequencies. The factor ΔV_{rms} is the same because the source voltage is fixed. According to Equation 33.27, changing $+\phi$ to $-\phi$ simply interchanges the values of X_L and X_C . Equation 33.25 tells us that such an interchange does not affect the impedance, so that the current I_{rms} in Equation 33.31 is the same for both frequencies.
- 33.9** (c). At resonance, $X_L = X_C$. According to Equation 33.25, this gives us $Z = R$.
- 33.10** (a). The higher the quality factor, the more sensitive the detector. As you can see from Figure 33.19, when $Q = \omega_0/\Delta\omega$ is high, a slight change in the resonance frequency (as might happen when a small piece of metal passes through the portal) causes a large change in current that can be detected easily.
- 33.11** (a) and (e). The current in an inductive circuit decreases with increasing frequency (see Eq. 33.9). Thus, an inductor connected in series with a woofer blocks high-frequency signals and passes low-frequency signals. The current in a capacitive circuit increases with increasing frequency (see Eq. 33.17). When a capacitor is connected in series with a tweeter, the capacitor blocks low-frequency signals and passes high-frequency signals.