

BASIC DESIGN 1

ORTHOGRAPHIC PROJECTION

Dr. Hatem Galal A Ibrahim

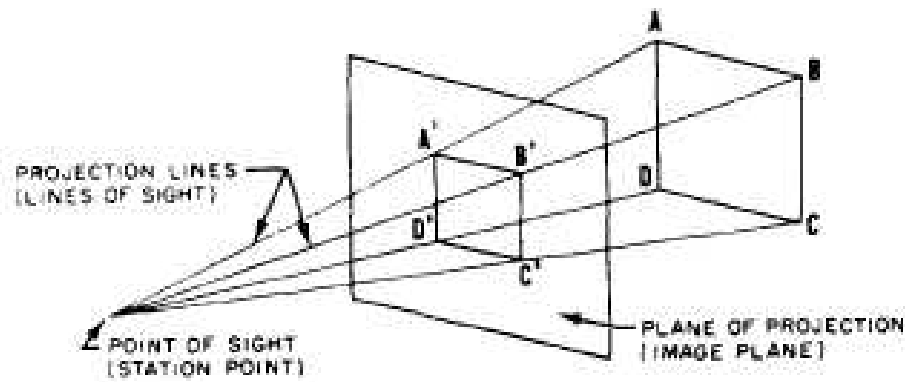

A. PERSPECTIVE PICTORIAL PROJECTION

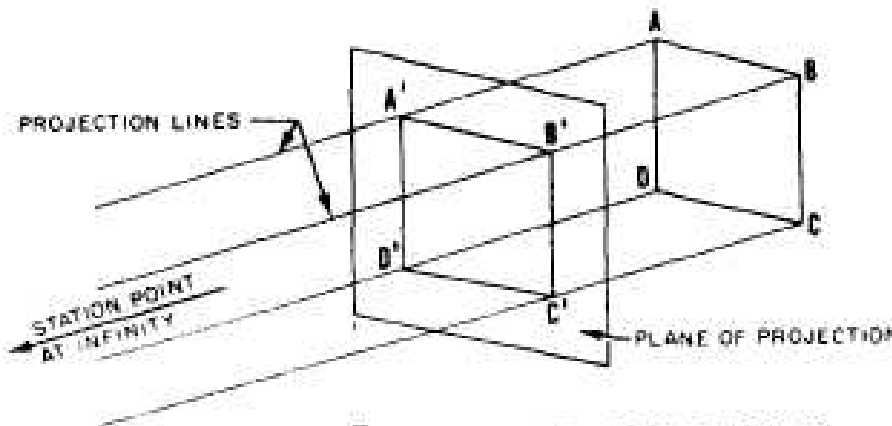

B. PARALLEL PROJECTIONS

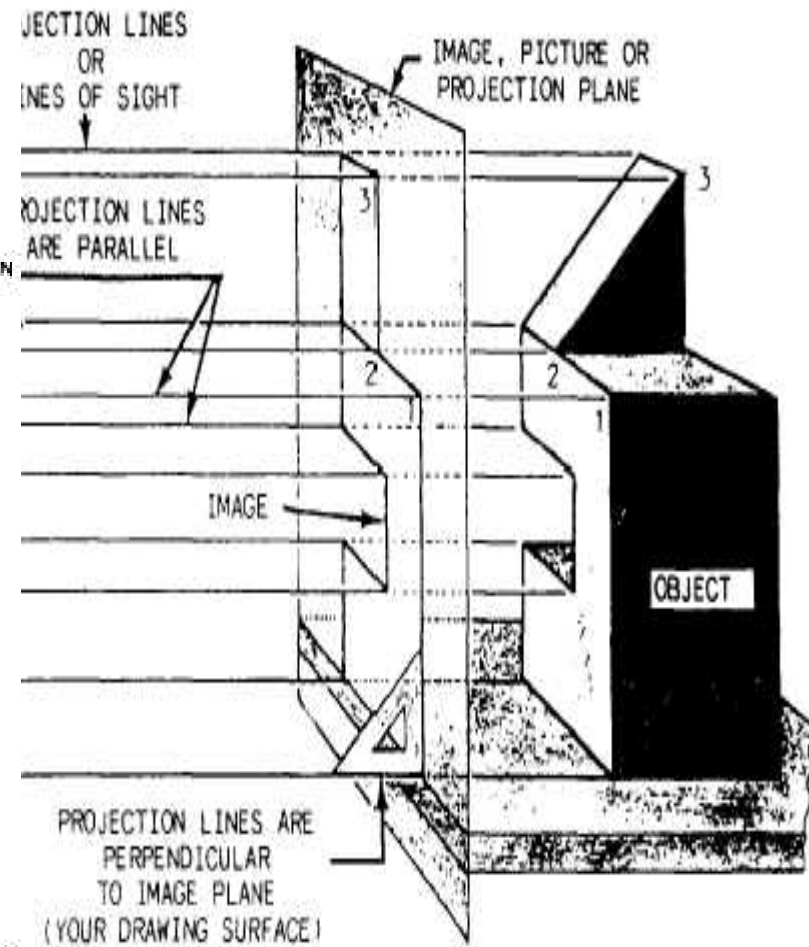

PROJECTION LINES
OR
LINES OF SIGHT

IMAGE, PICTURE OR
PROJECTION PLANE

PROJECTION LINES
ARE PARALLEL

IMAGE

OBJECT

PROJECTION LINES ARE
PERPENDICULAR
TO IMAGE PLANE
(YOUR DRAWING SURFACE)

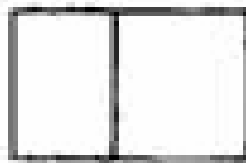
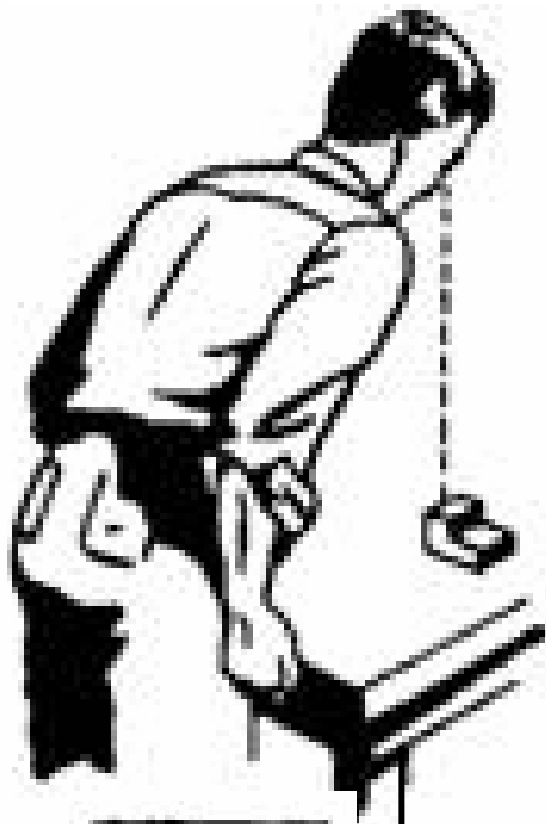

TOP

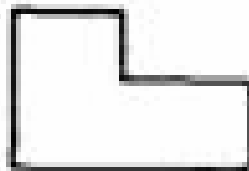

FRONT

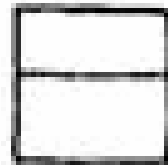

SIDE

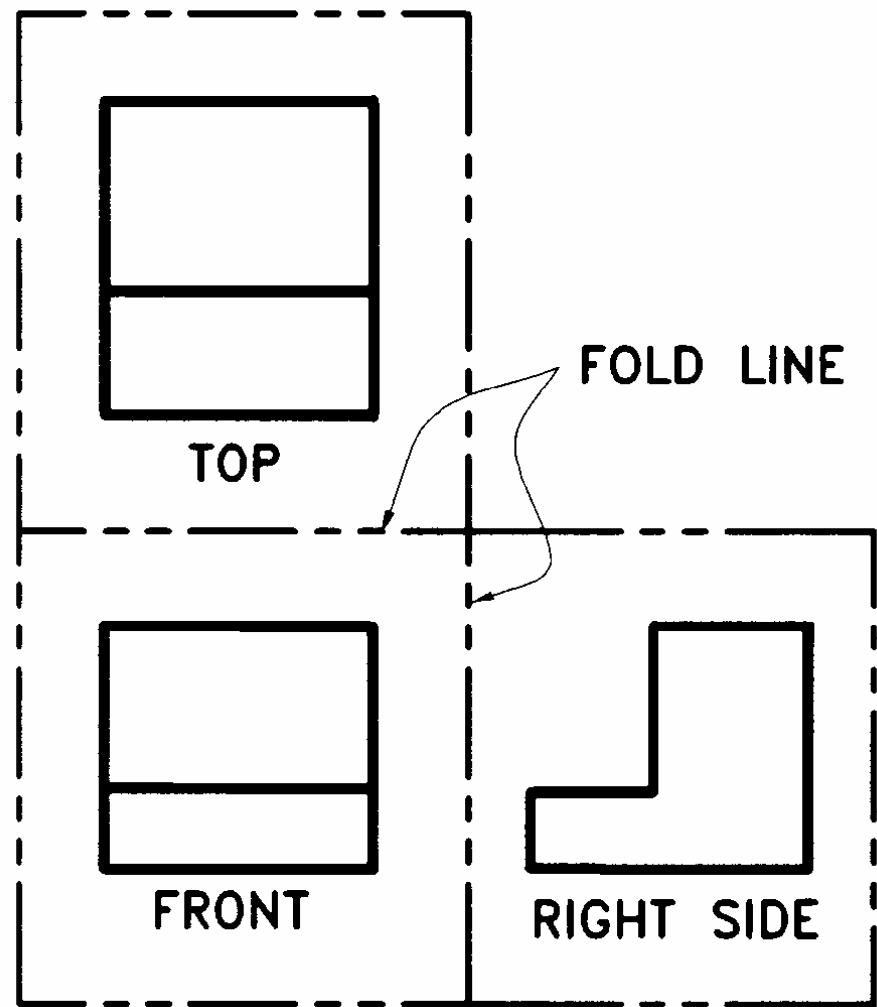
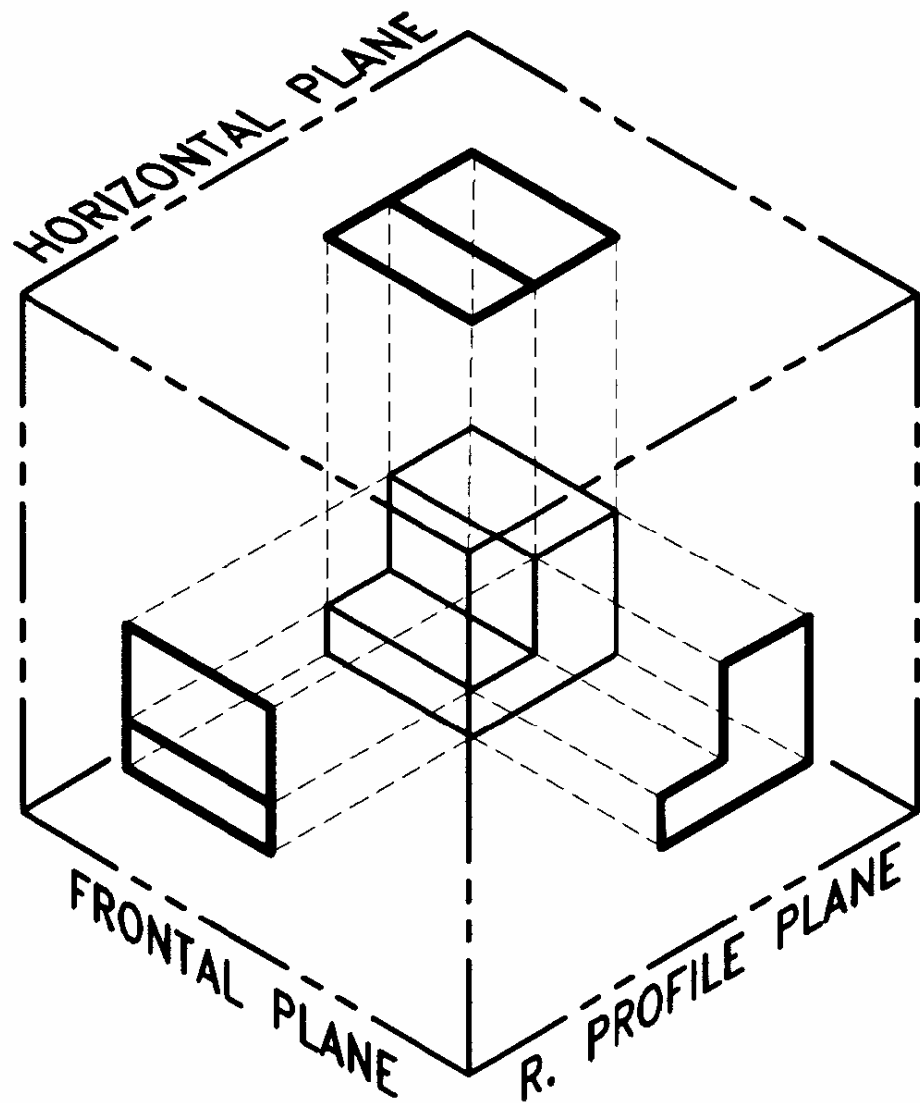

MULTIVIEW USING
THIRD-ANGLE
PROJECTION

FRONT, TOP AND SIDE VIEW OF A 3D FORM

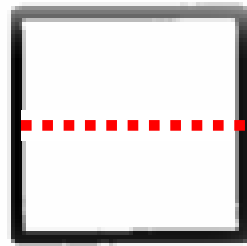
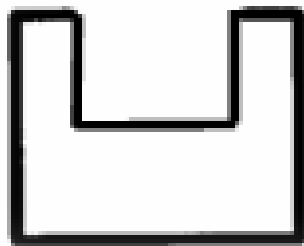
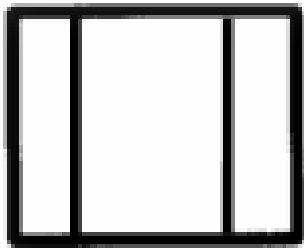

(a)

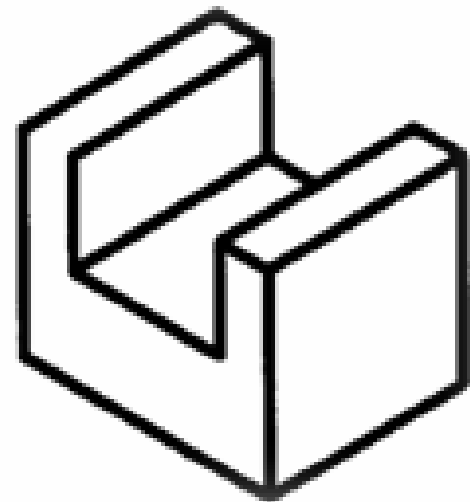

FRONT, TOP AND SIDE VIEW OF A 3D FORM

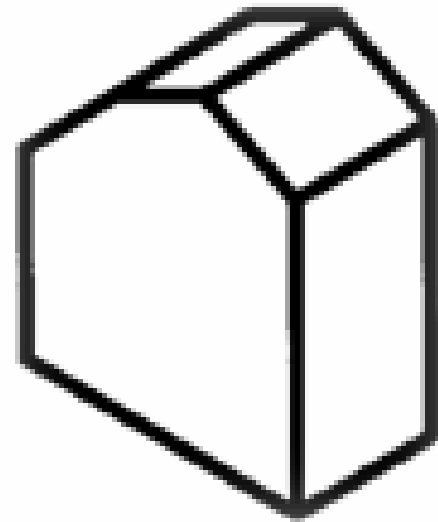
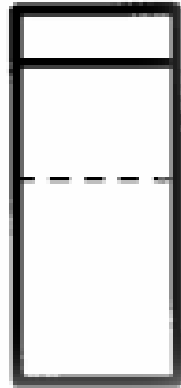
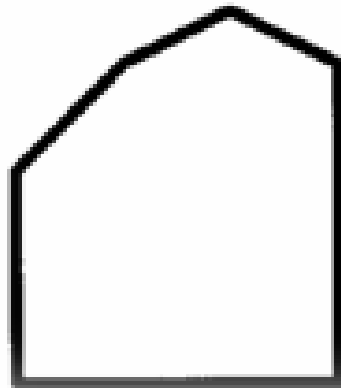
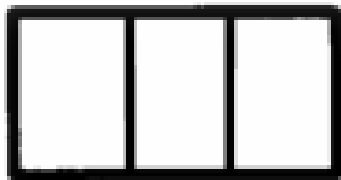

FRONT, TOP AND SIDE VIEW OF A 3D FORM

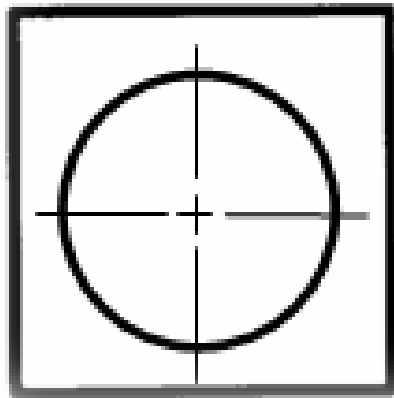
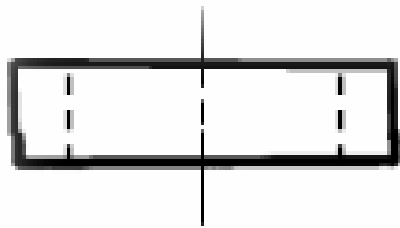

(c)

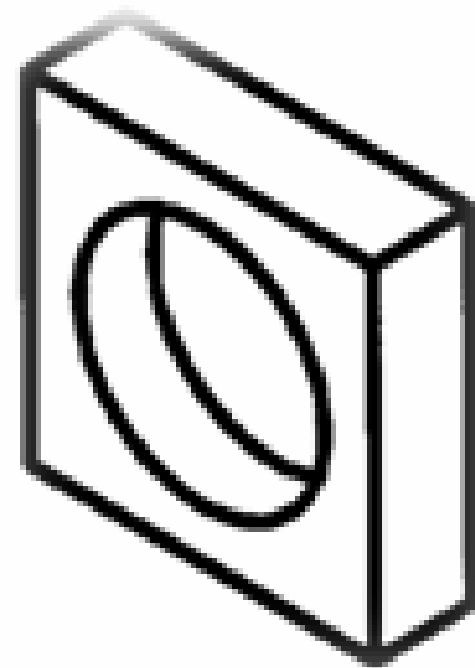
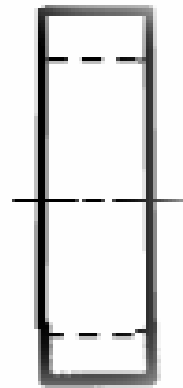

FRONT, TOP AND SIDE VIEW OF A 3D FORM

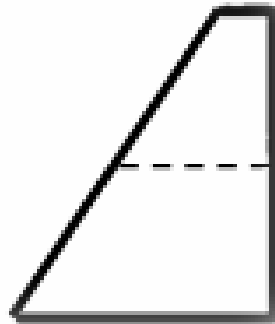
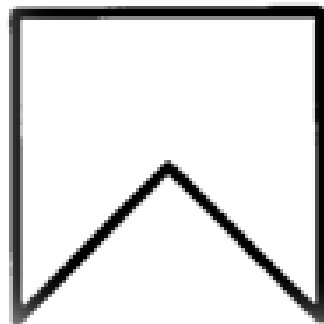
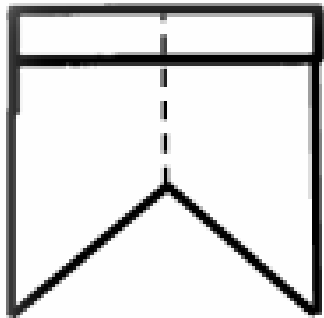

(d)

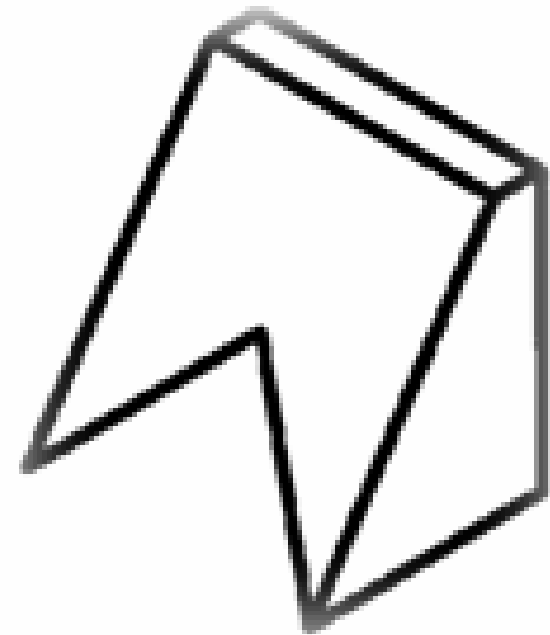

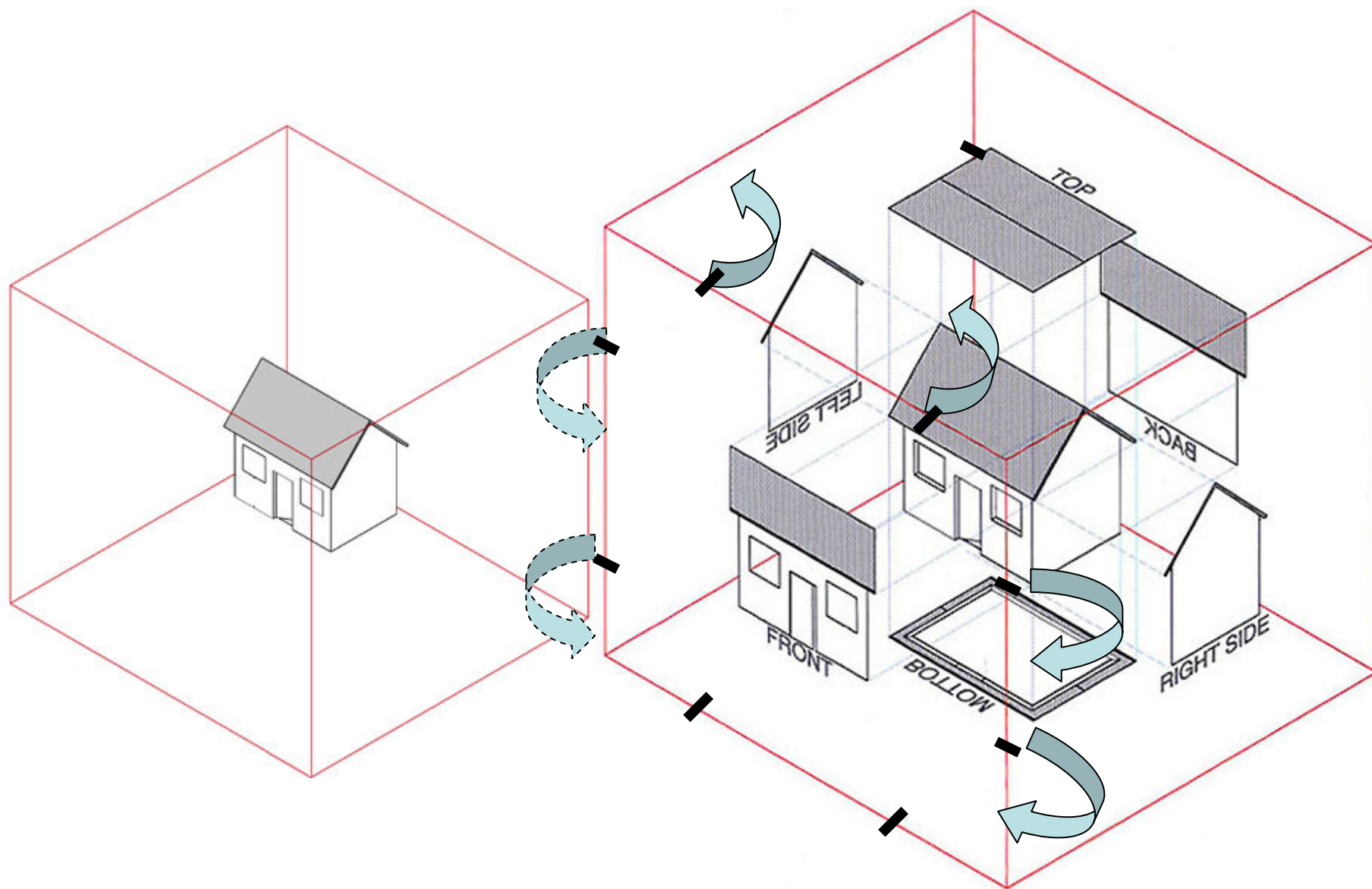

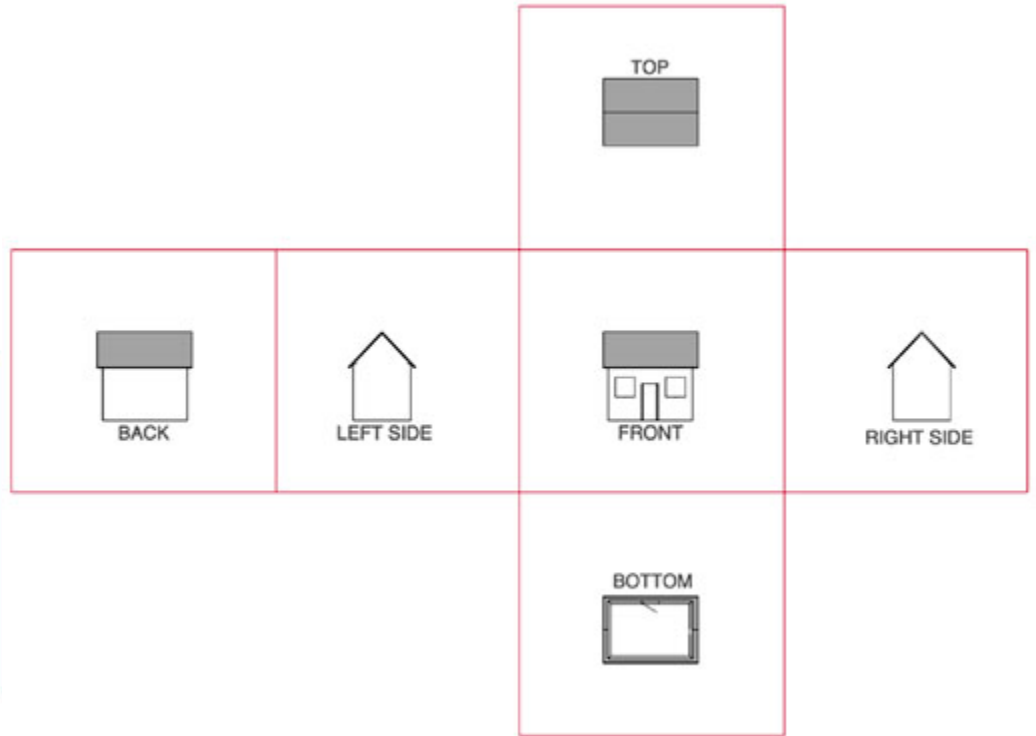
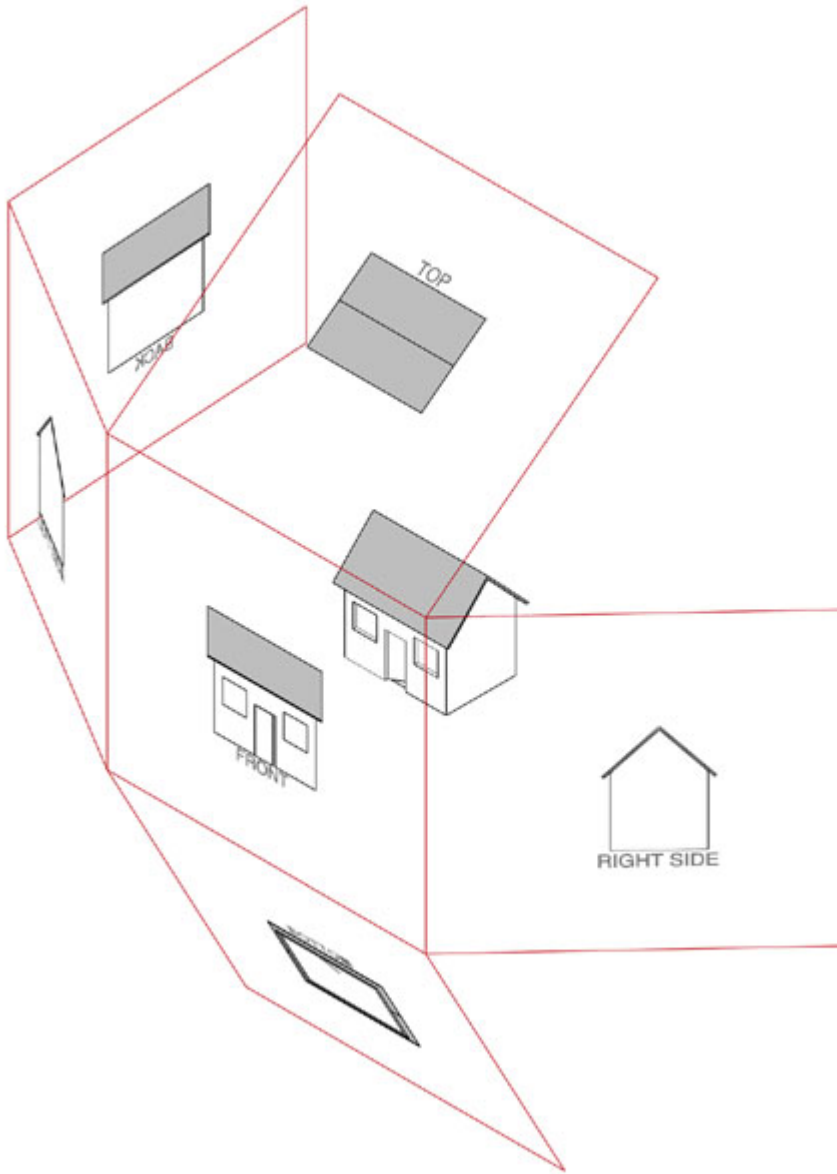

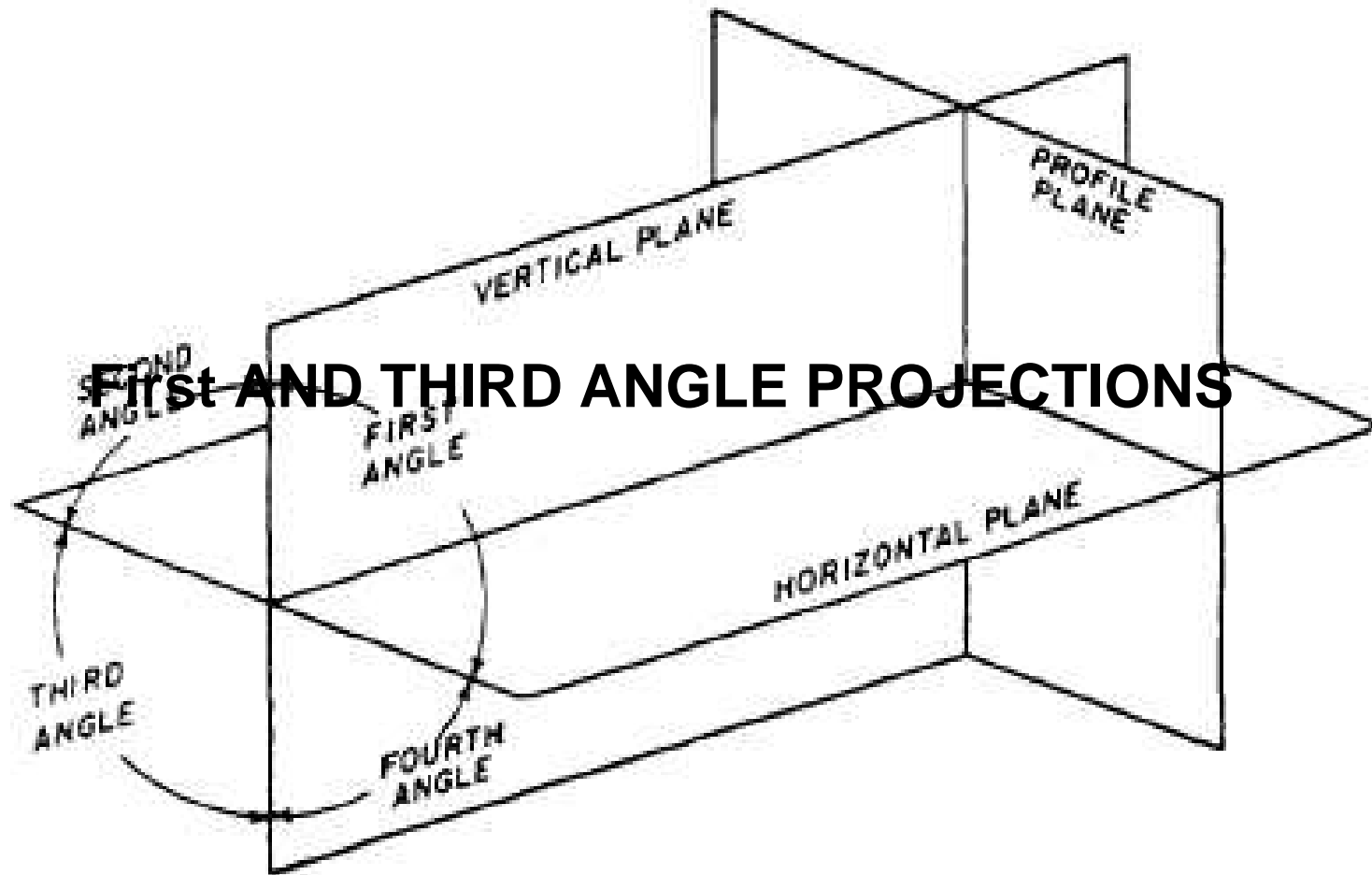

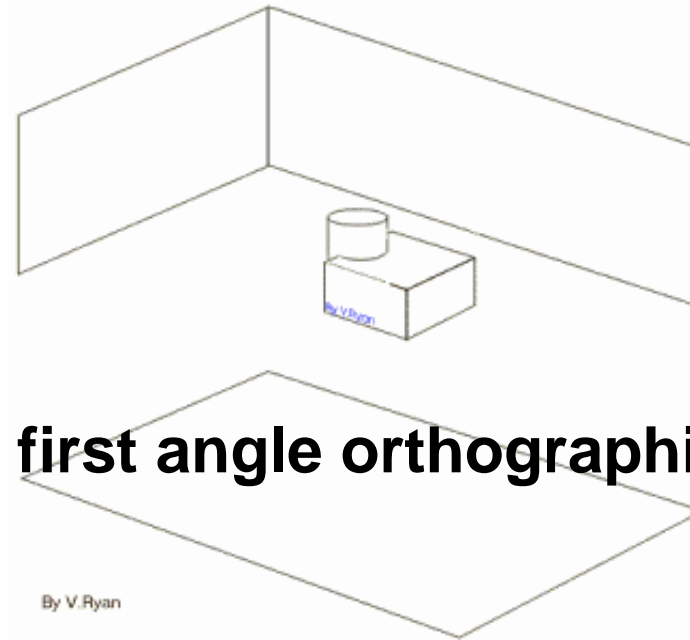

example of first angle orthographic projection

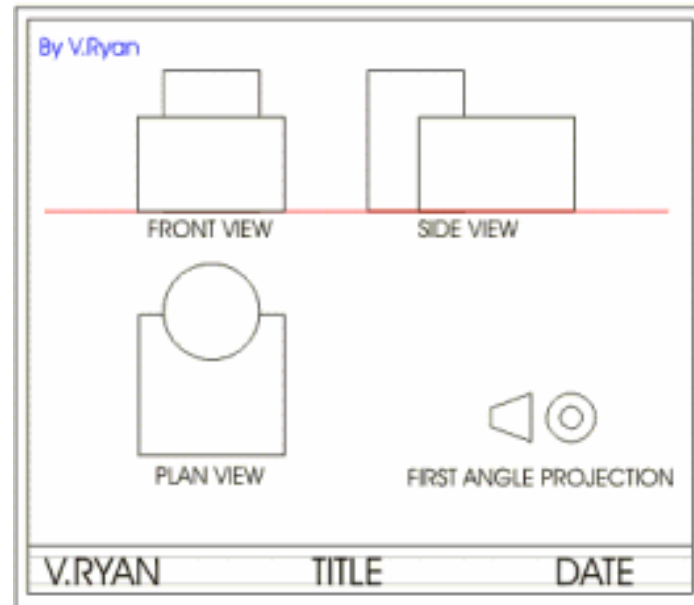

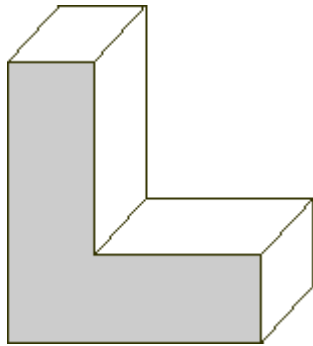

3D L Shape

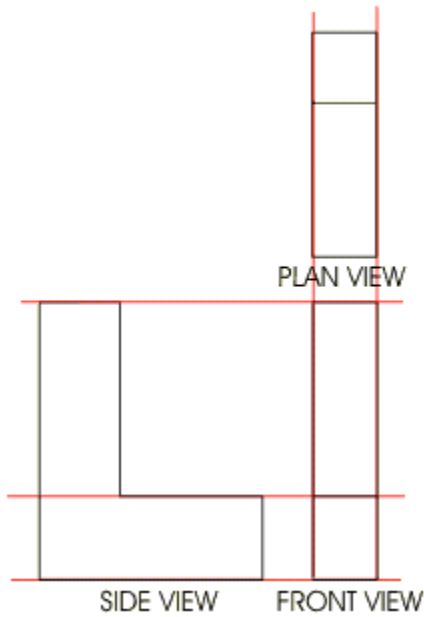

The shape drawn in orthographic projection

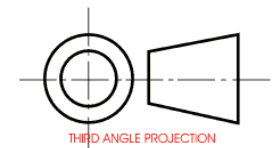
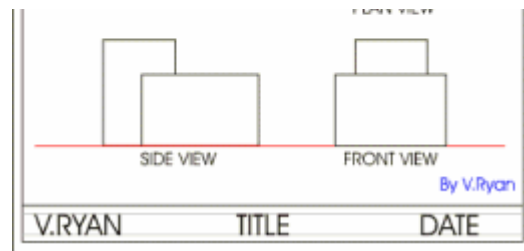
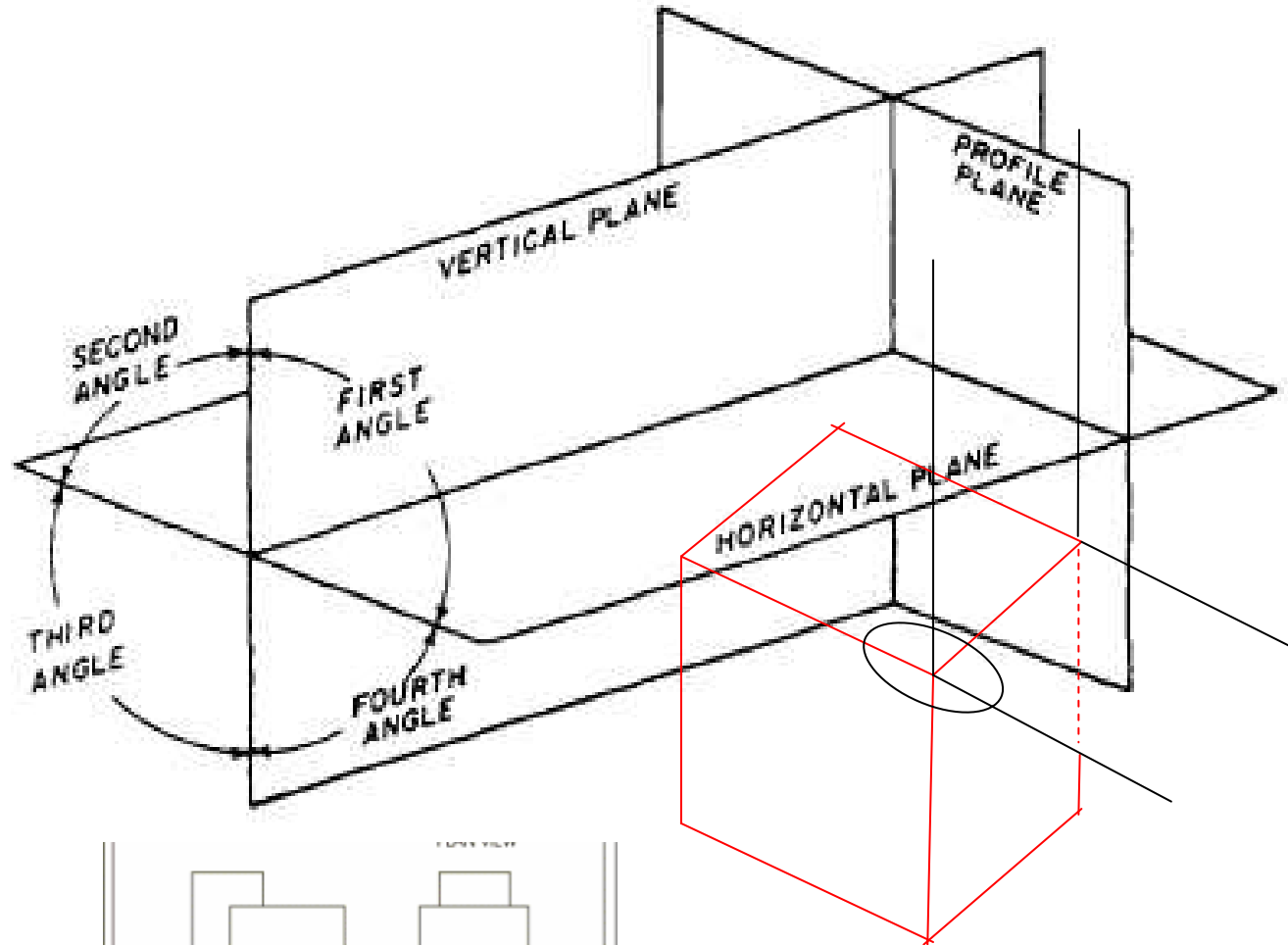

FIRST ANGLE PROJECTIONS

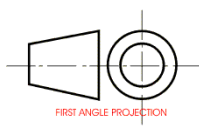
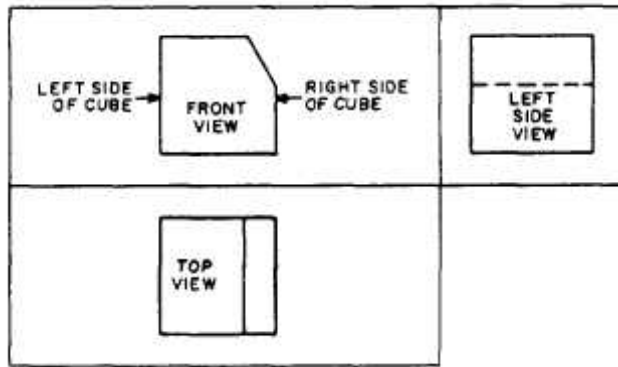
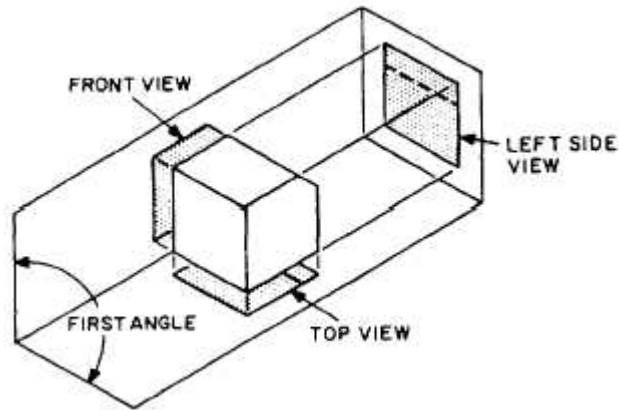

THIRD ANGLE PROJECTIONS

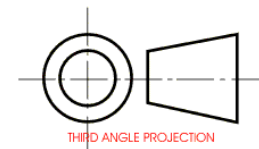
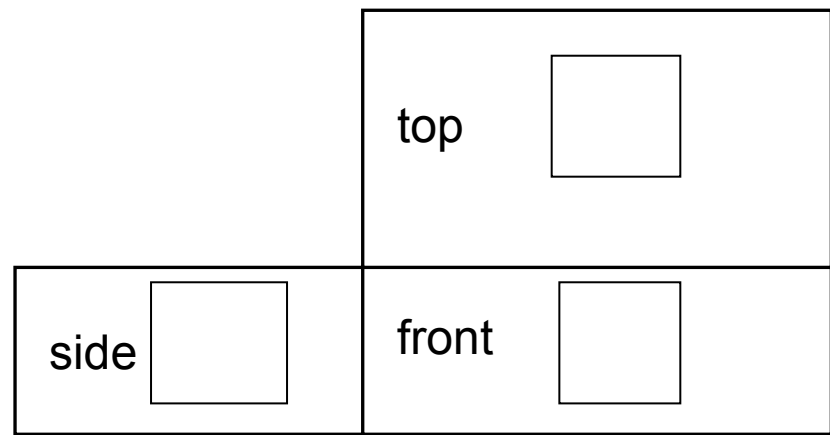
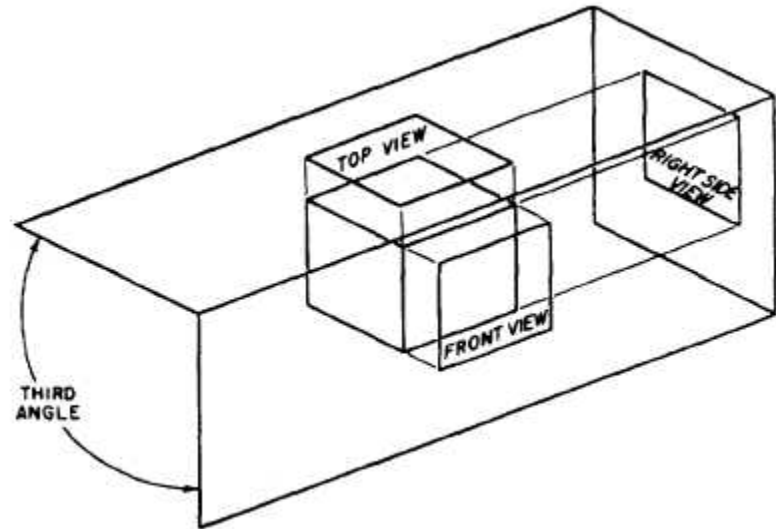

Orthographic Projection

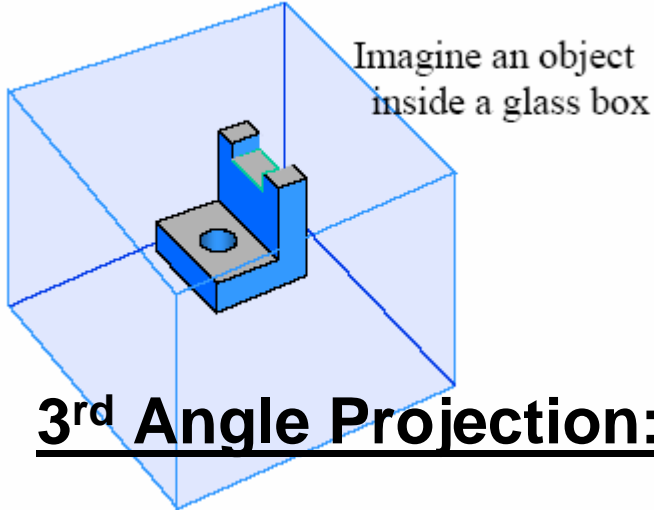

The object's image is formed on the projection plane by the pierce points of the visual rays.

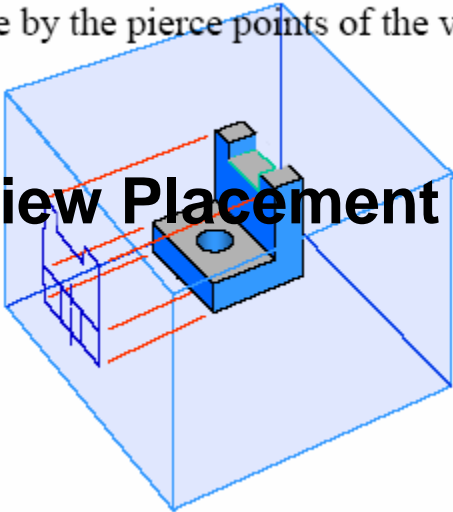

3rd Angle Projection: Three View Placement

Parallel visual rays project from the object to the projection plane.

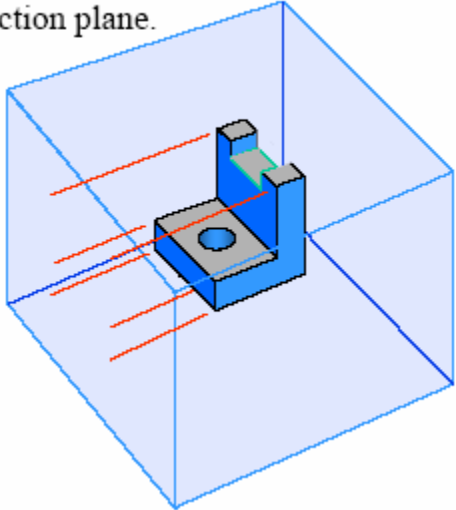

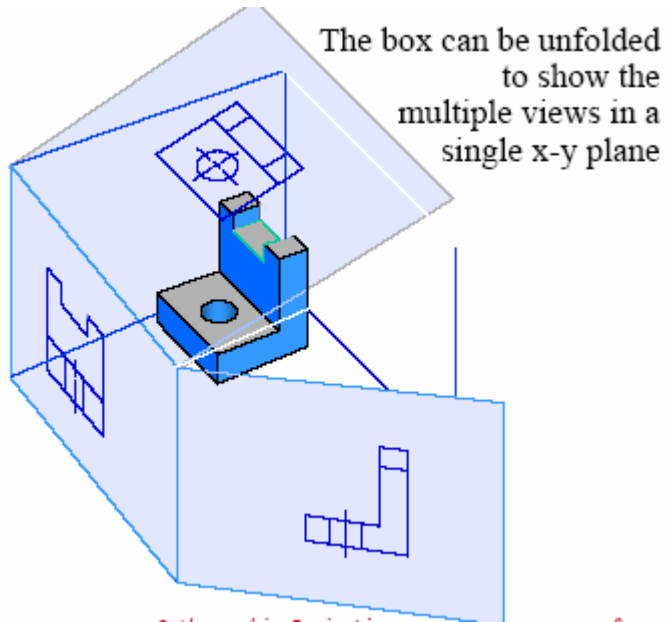
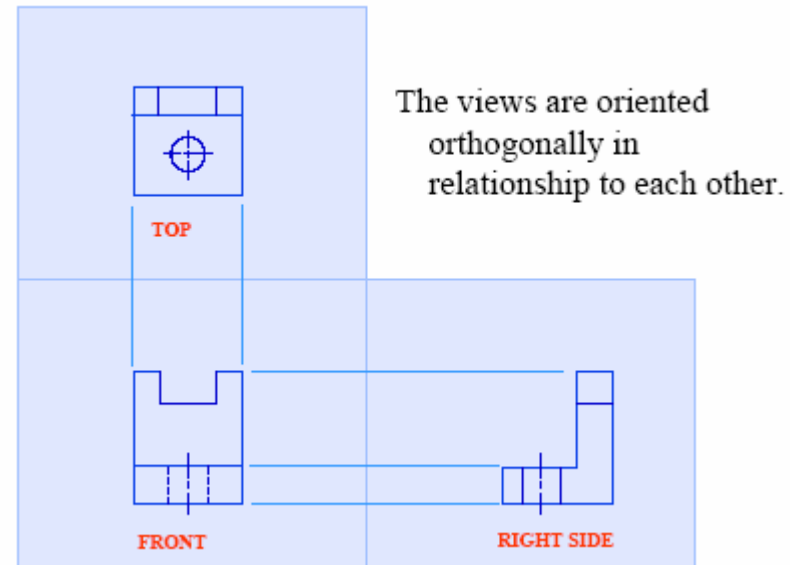
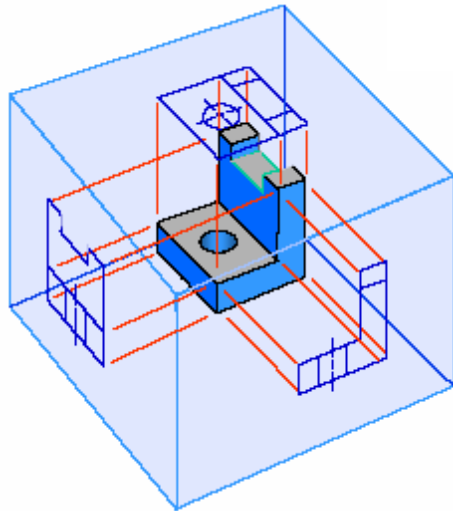

Typical Three-View Placement

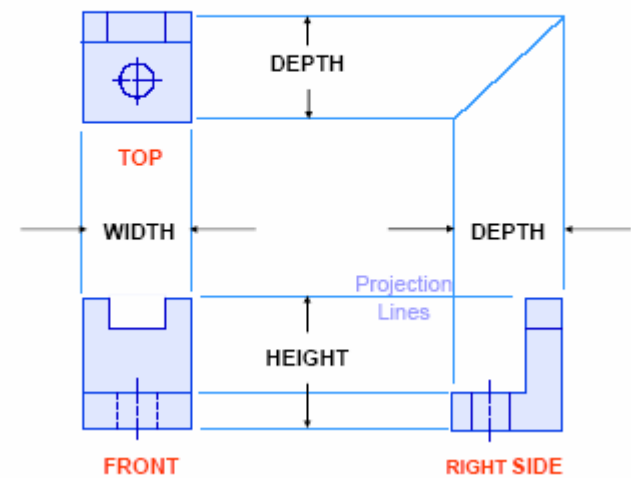

THIRD ANGLE PROJECTIONS

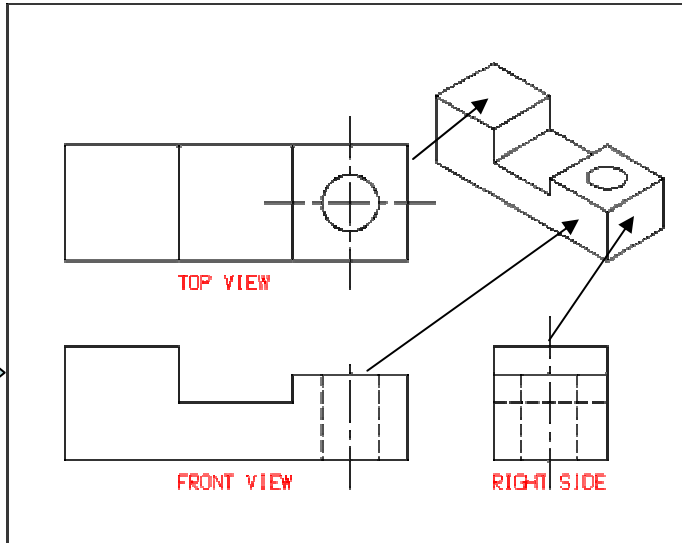
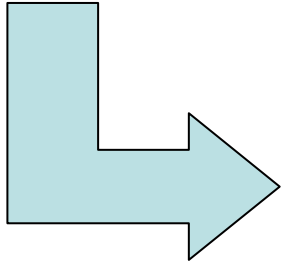

FIRST ANGLE PROJECTIONS

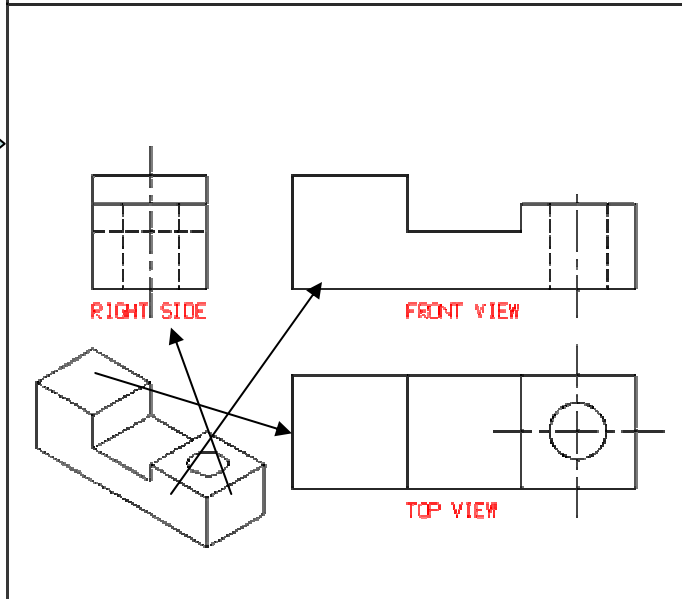
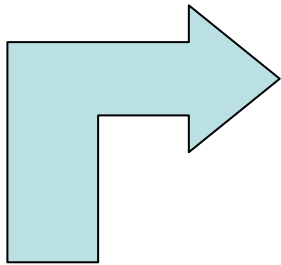

DRAW THE THIRD VIEW

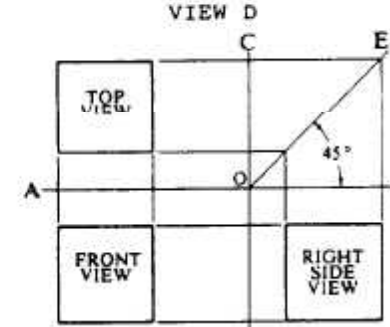
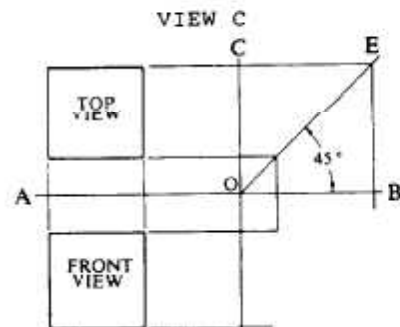
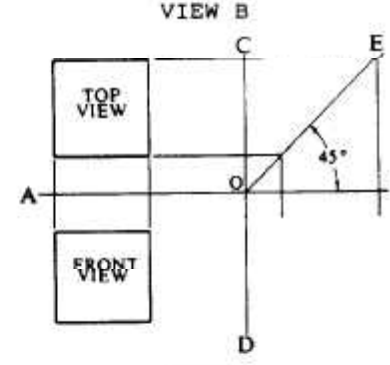
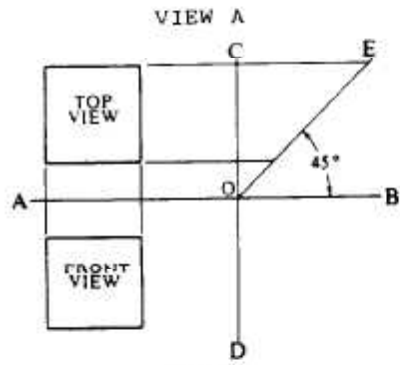
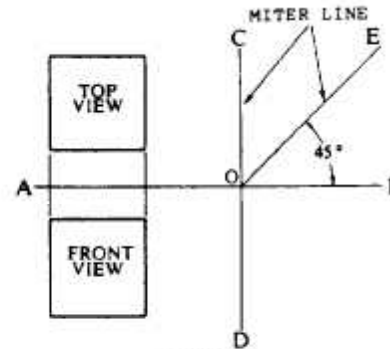
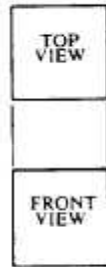

ثم بحمد الله