

Defect testing

- **Testing is the process of exercising a program with the specific intent of finding errors prior to delivery to the end user.**

Objectives

- To understand testing techniques that are geared to discover program faults
- To introduce guidelines for interface testing
- To understand the principles of CASE tool support for testing

Topics covered

- Defect testing
 - ✚ Exhaustive Testing
 - ✚ Black-box testing
 - ✚ Equivalence partitioning
 - ✚ White-box ‘Structural’ testing
 - ✚ Path testing
- Integration testing
- Interface testing
- Stress testing
- Object-oriented (OO) testing
- Monkey testing
- Testing workbenches
- Automated testing – See JUnit & XUnit frameworks

What Testing Shows

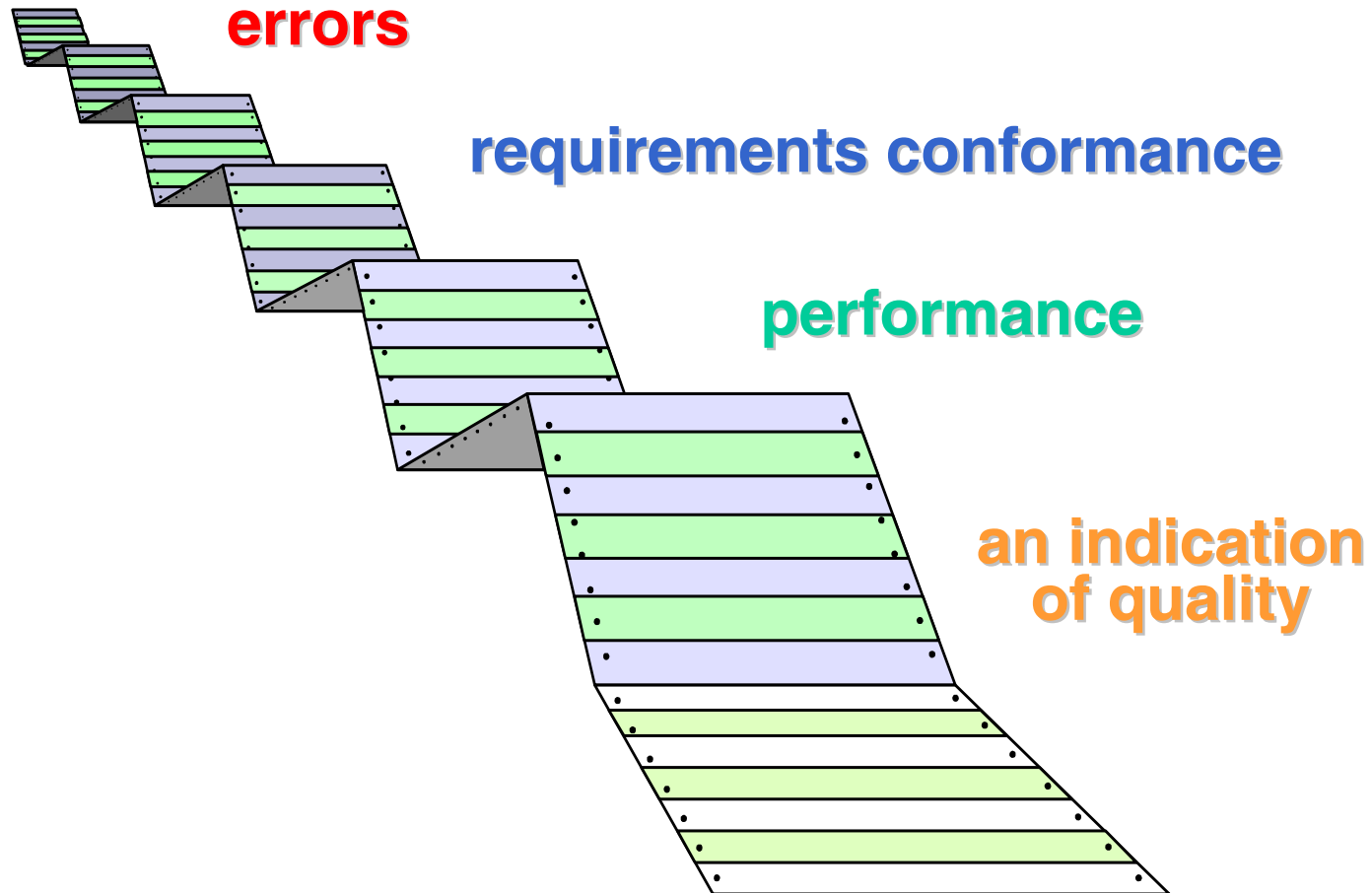

Who Tests the Software

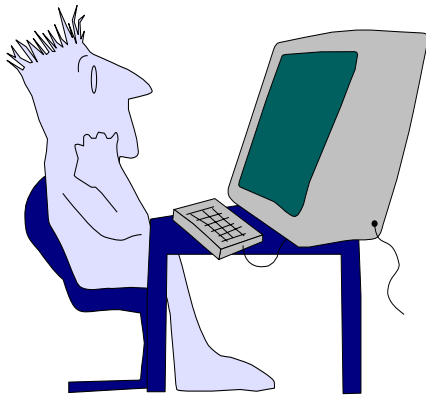

Developer

- understands the system
- has the source code
- white-box 'Unit' testing
- will test "gently"
- driven by delivery 'schedule' constraint

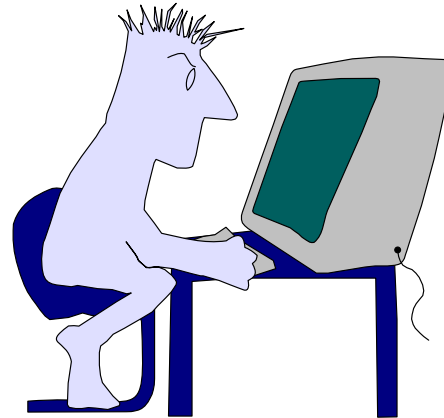

Independent tester

- must learn about the system
- has no source code
- black-box 'Acceptance' testing
- will attempt to break the sys (ME!!)
- driven by quality constraint

Testing phases

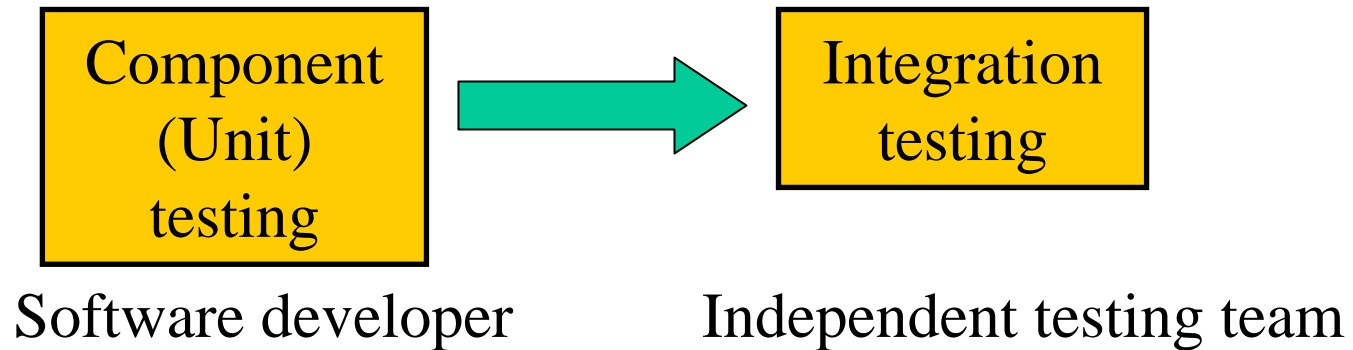

The testing process

- Component (**Unit**) testing: **needs source code (White-box)**
 - ✚ Testing of individual program components
 - ✚ Usually the responsibility of the **component developer**
 - ✚ Tests are derived from the **developer's experience**
- Integration testing (**Acceptance testing, Black-box testing**)
 - ✚ Testing of groups of components integrated to create a system or sub-system
 - ✚ The responsibility of an **independent testing team**
 - ✚ Tests are based on a **system specification (Acceptance testing)**

Exhaustive Testing

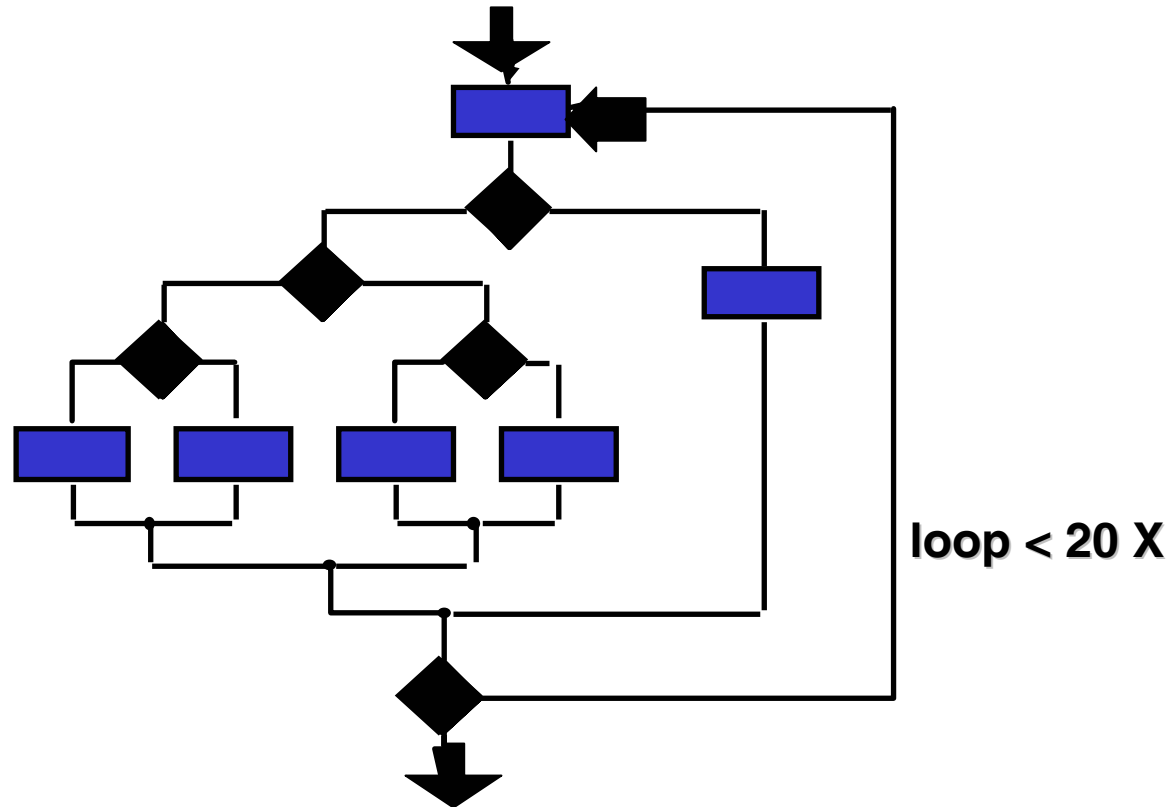

If there are 10^{14} possible paths and we execute one test per millisecond, it would take **3,170 years** to test this program!!

Test Case Design

"Bugs lurk in corners
and congregate at
boundaries ..."

Boris Beizer

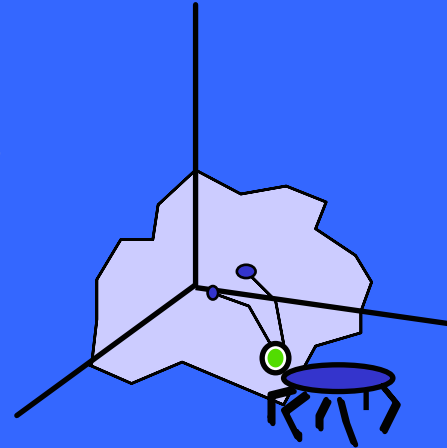

OBJECTIVE to uncover errors

CRITERIA in a complete manner

CONSTRAINT with a minimum of effort and time

Test data and test cases

- *Test data*
 - ✚ Inputs to test the system
- *Test cases ‘Test scenario’ includes:*
 - ✚ Inputs to test the system
 - ✚ and the **predicted outputs**

The defect testing process

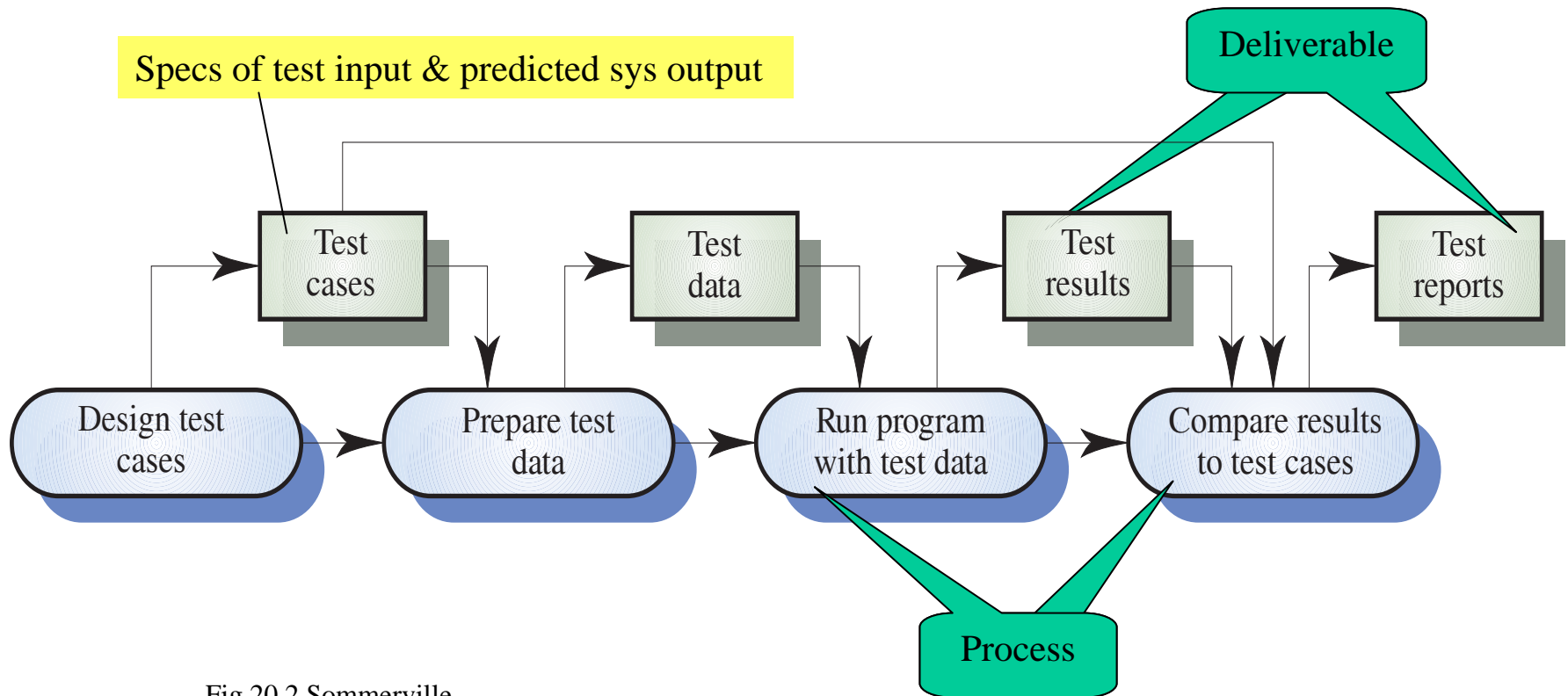

Fig 20.2 Sommerville

Black-box testing

- Program is considered as a ‘black-box’
- No need to know or access source code
- Functionality testing
- No implementation testing (implementation testing needs source code)
- Test cases are based on the system specification
- Test planning can begin early in the software process

Black-box Testing

“Functionality testing”

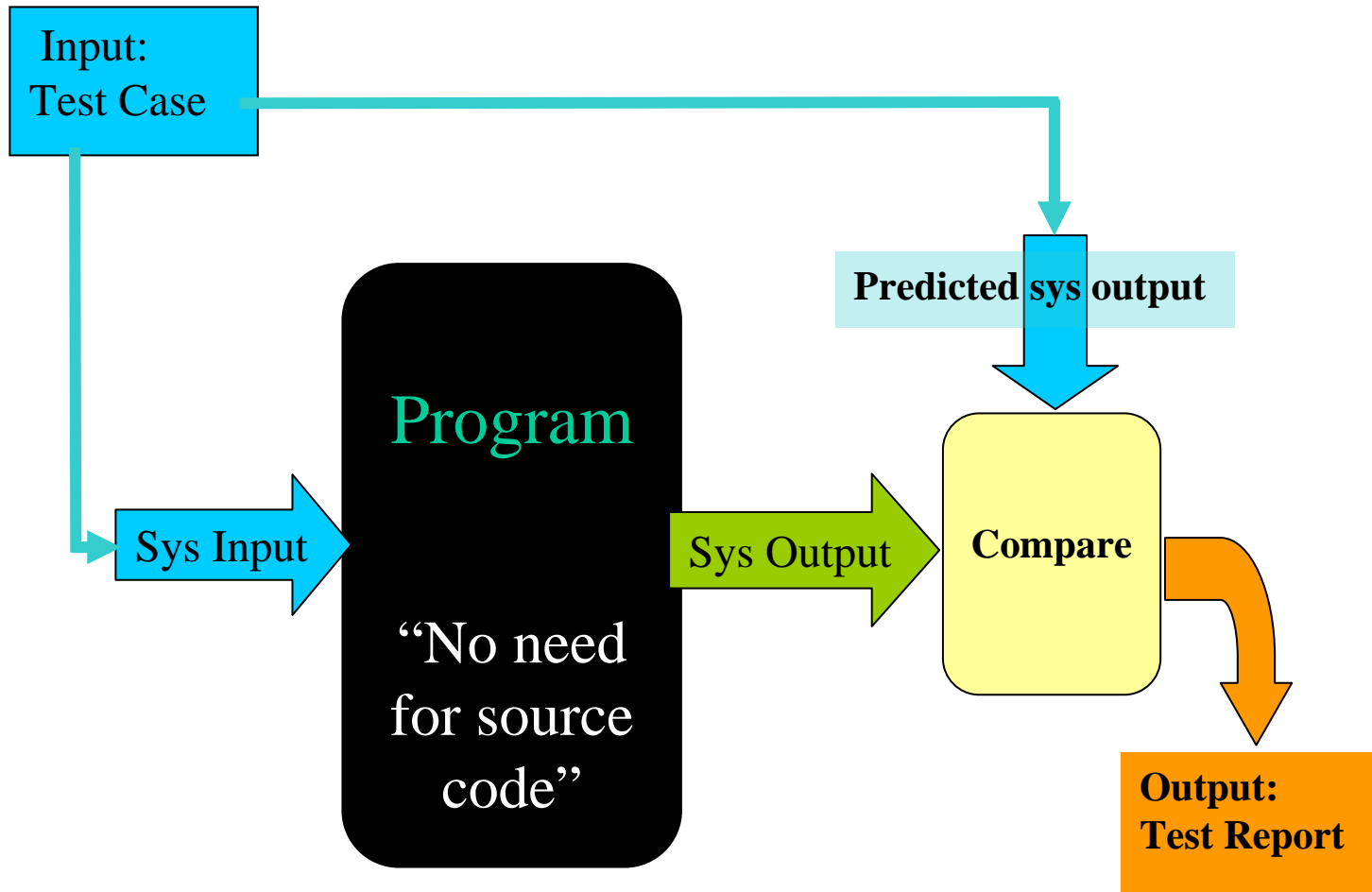

Black-box Testing

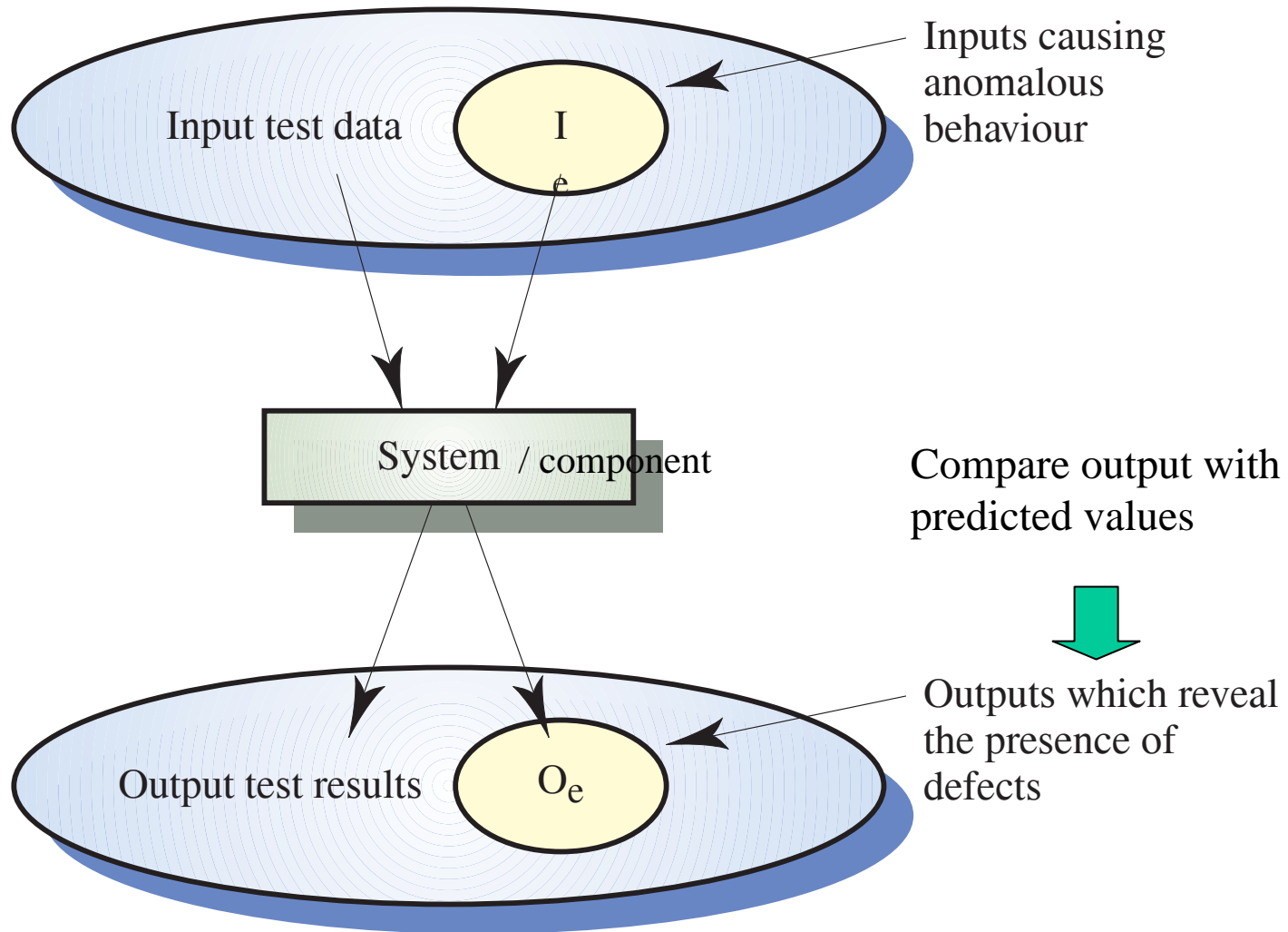

Equivalence partitioning

- Objective:

Reduce the number of test cases

Equivalence partitioning - cont.

- A way to derive test cases
- Is a **black-box** testing method
- Input data with common characteristics (positive numbers, negative numbers, strings without blanks, etc)
- Each of these classes is an equivalence partition
- Program behaves in an equivalent way for each member of an **Equivalence partition**
- Divides the input domain into classes of data form which test cases can be derived

Equivalence partitioning – cont.

Input

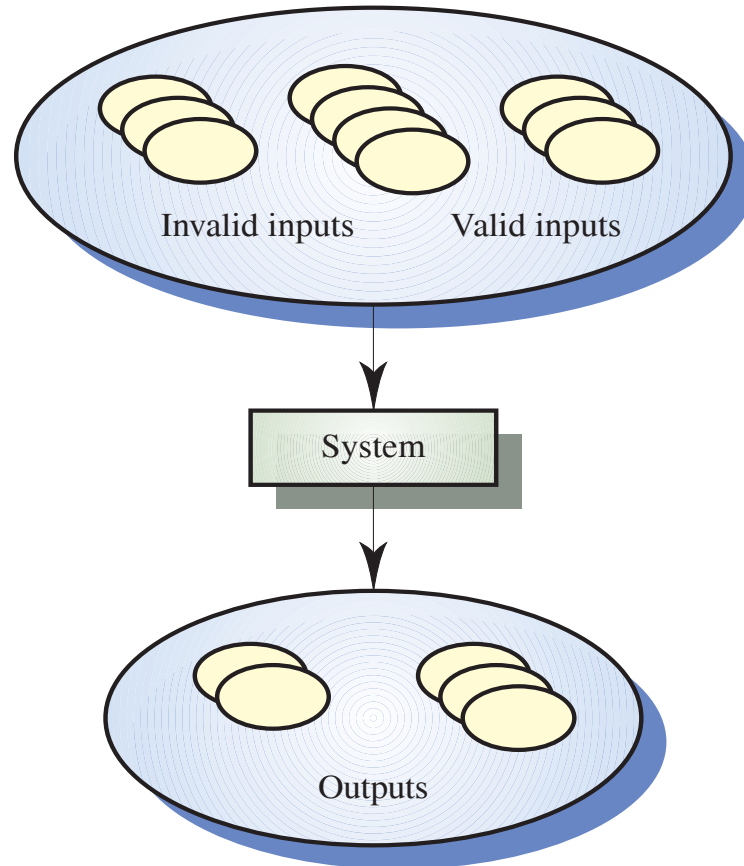

Equivalence partitioning - cont.

- Guide lines for test case selection for partitions
 - ✚ At the **boundaries** of the partition
 - ✚ Close to **mid-point** of the partition

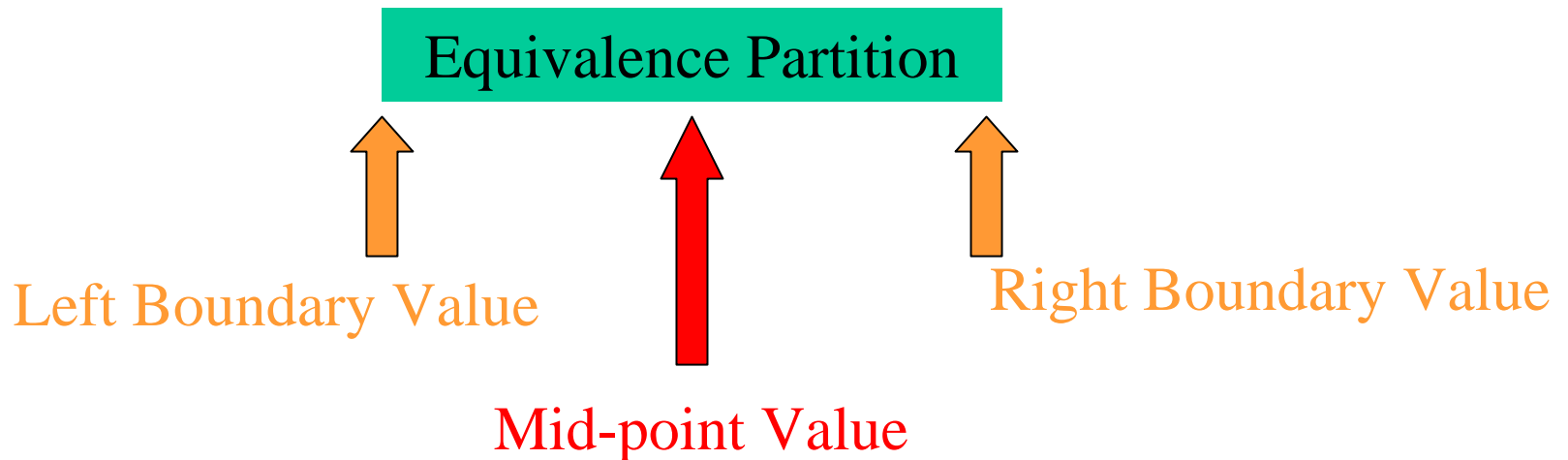

Equivalence partitioning - Example 1

- Program specs states:
 - ✚ Accepts 4 to 10 inputs
 - ✚ Each input is 5-digit integer greater than 10,000
- Partition system inputs and outputs into ‘equivalence sets’

Equivalence partitioning - cont.

Example

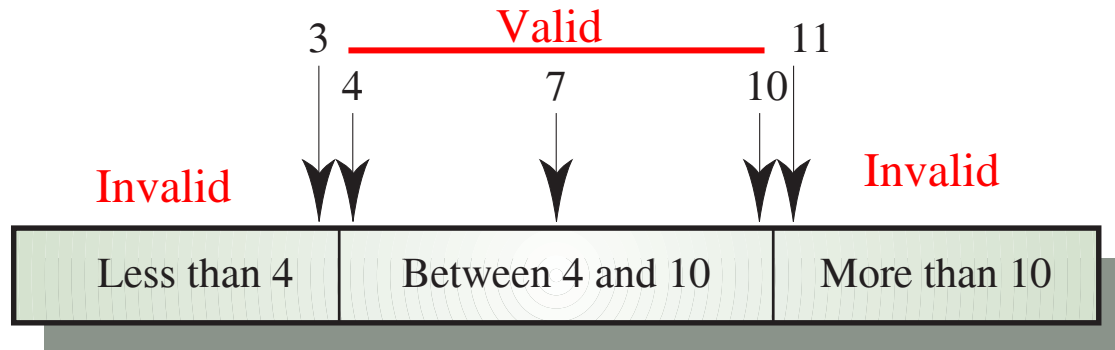

Number of input values

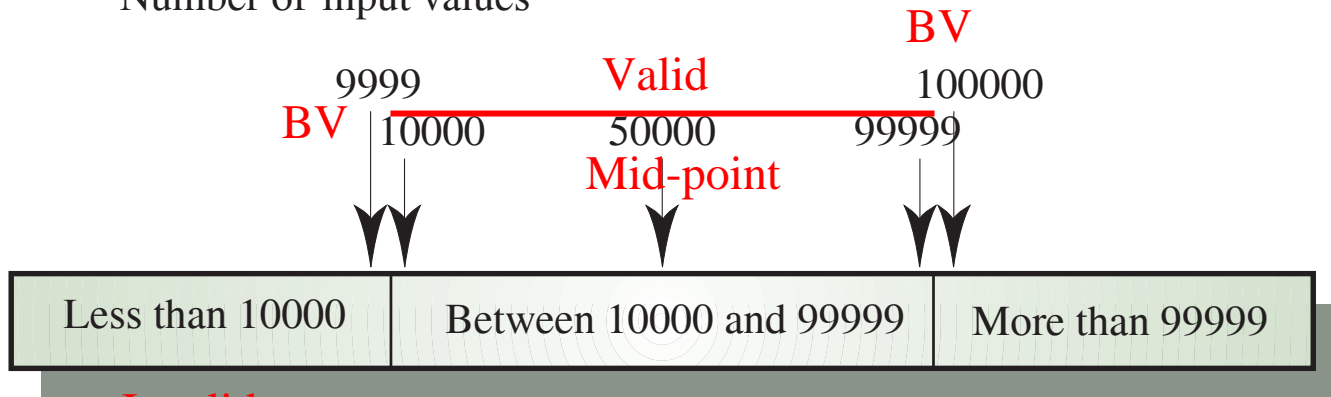

Invalid
Input values

Invalid

Equivalence partitioning - cont.

Example 1

- If input is a 5-digit integer between 10,000 and 99,999, **equivalence partitions** are (fig 20.5 Sommerville)
 - ✚ <10,000,
 - ✚ 10,000 - 99, 999
 - ✚ and > 99, 999
- Test cases - 6 cases
 - ✚ 00000, (invalid special value that may be checked)
 - ✚ 09999, (invalid left boundary value)
 - ✚ 10000, (valid left boundary value)
 - ✚ 50000, (valid mid value)
 - ✚ 99999, (valid right boundary value)
 - ✚ 100000, (invalid right boundary value)

Remember: Bugs lurk in corners & congregate at boundaries

Structural testing ‘White-box testing’

- **Glass-box, Clear-box, Transparent-box**
- For small program units
- Needs **source code**

- Objective: is to exercise **all program statements**
- (not all path combinations)

- Fig 20.8

White-box testing

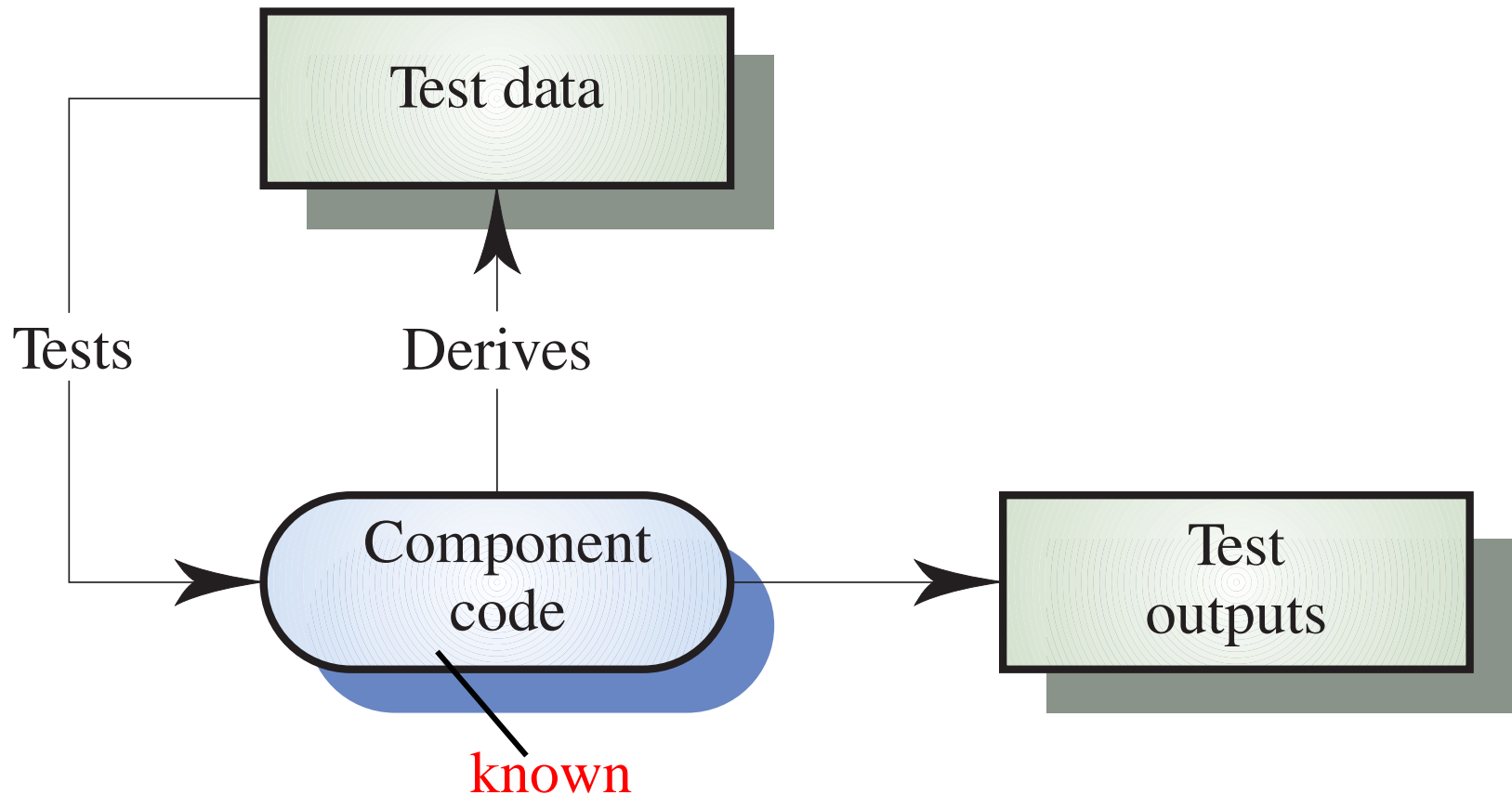

Path testing

- Each path through the program is executed **at least once**
- For loops & conditions
- Used at **unit testing** and **module testing** levels

Program flow graphs (Diagraph)

- **Flow Graph (Diagraph) :**
 - ✚ nodes representing program decisions
 - ✚ arcs (edges) representing the flow of control
 - ✚ **Ignore sequential statements** (assignments, procedures calls, I/O)
- Statements with conditions are therefore nodes in the flow graph
- **Cyclomatic complexity =**
Number of edges - Number of nodes + 2

Cyclomatic complexity

- Cyclomatic complexity = **number of tests** to test **all control** statements
- Cyclomatic complexity equals number of conditions in a program
- Although all paths are executed, all combinations of paths are not executed

Path testing

Binary search flow graph

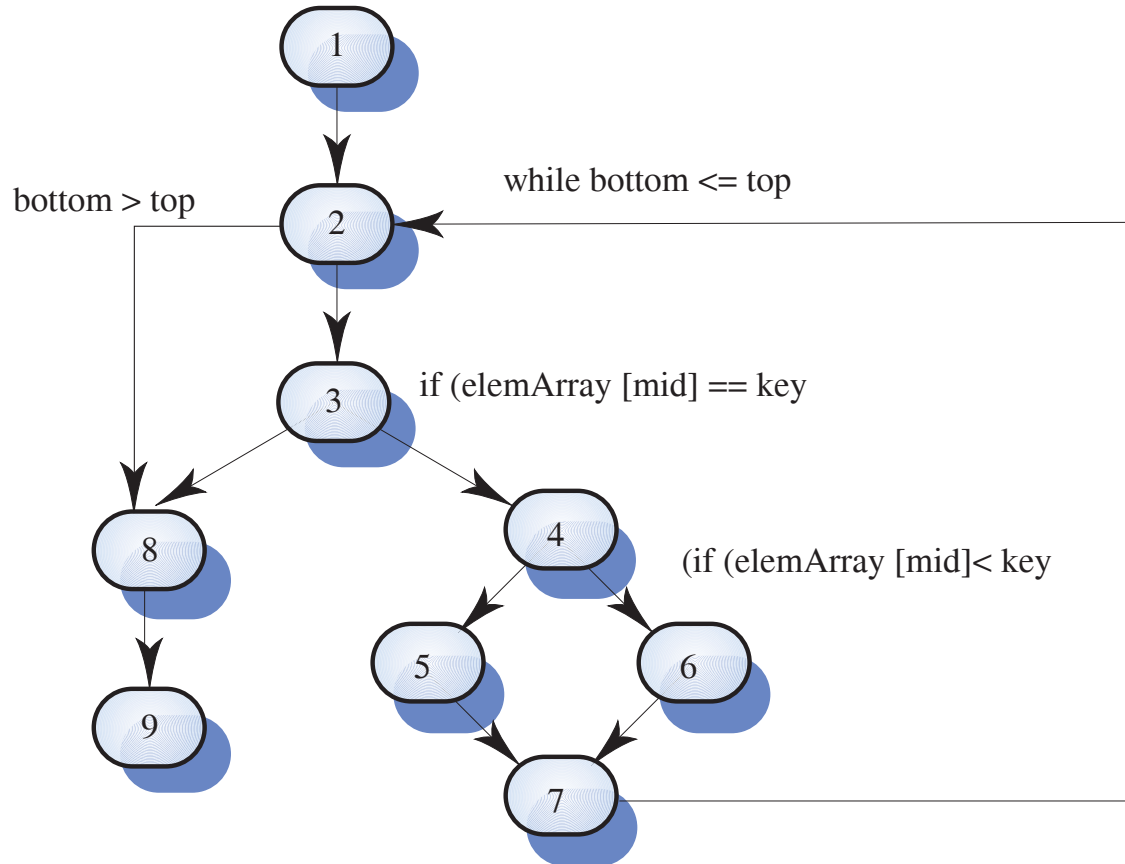

Independent paths

- **Cyclomatic complexity = $11 - 9 + 2 = 4$**
- Thus 4 independent paths:
- 1, 2, 3, 8, 9
- 1, 2, 3, 4, 6, 7, 2
- 1, 2, 3, 4, 5, 7, 2
- 1, 2, 3, 4, 6, 7, 2, 8, 9
- Test cases should be derived so that **all of these paths are executed**

Integration testing (**black-box**)

- Tests complete systems or subsystems composed of integrated components
- Integration testing should be **black-box** testing with tests derived from the **specification**
- Main difficulty is localising errors
- **Incremental integration** testing reduces this problem - (XP)

Incremental integration testing

Recall: XP Continuous Integration of: Stories + (Acceptance & Unit Tests)

Minimal system

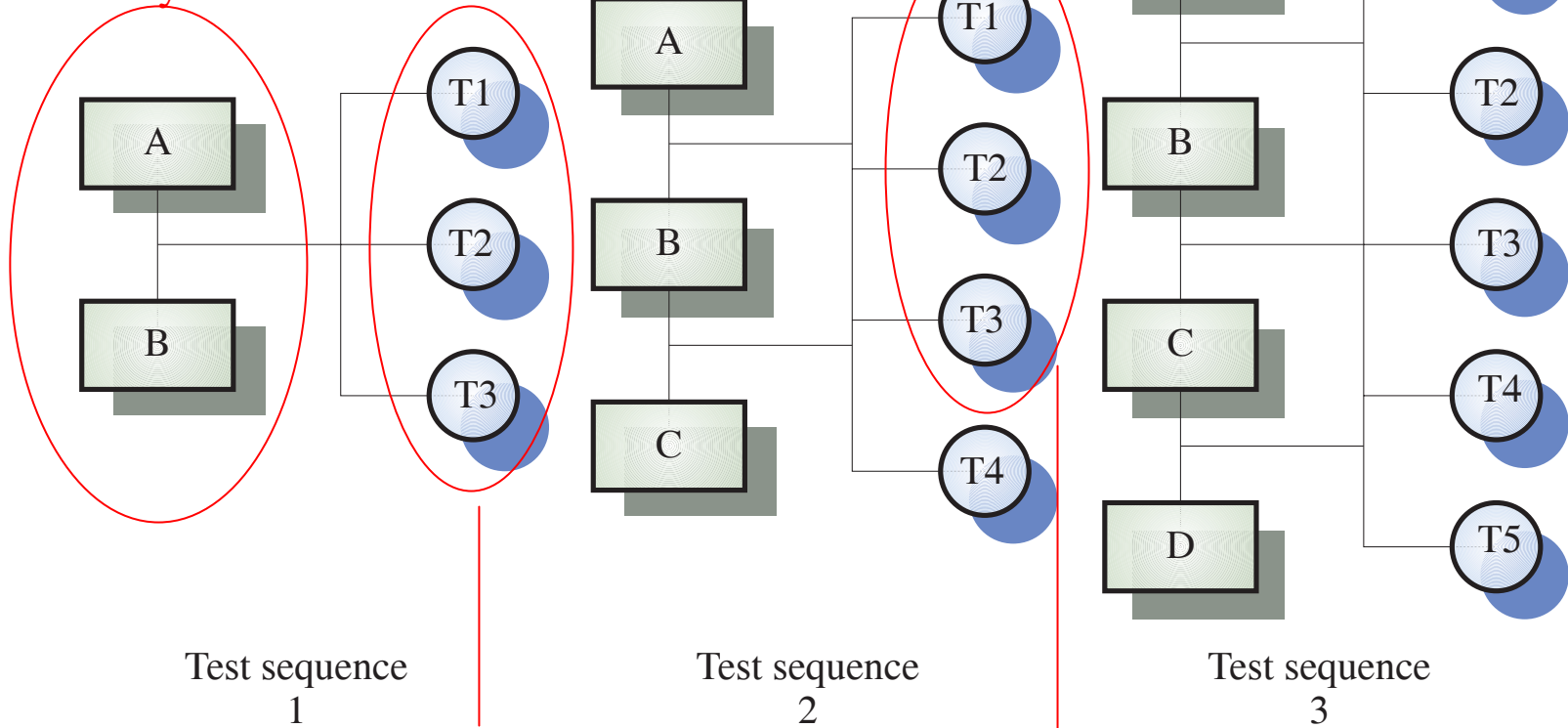

T1, T2, T3 are repeated to insure right interaction of C with A & B

Approaches to integration testing

- Top-down integration testing
 - ✚ Start with high-level system and integrate from the top-down replacing individual components by **stubs**
 - ✚ **Stubs** have the **same interface** as the components but **very limited functionality**
- Bottom-up integration testing (XP)
 - ✚ Integrate and test low-level components (or stories in XP), with **full functionality**, before developing higher level components, until the complete system is created
- In practice, combination of both

Top-down integration testing

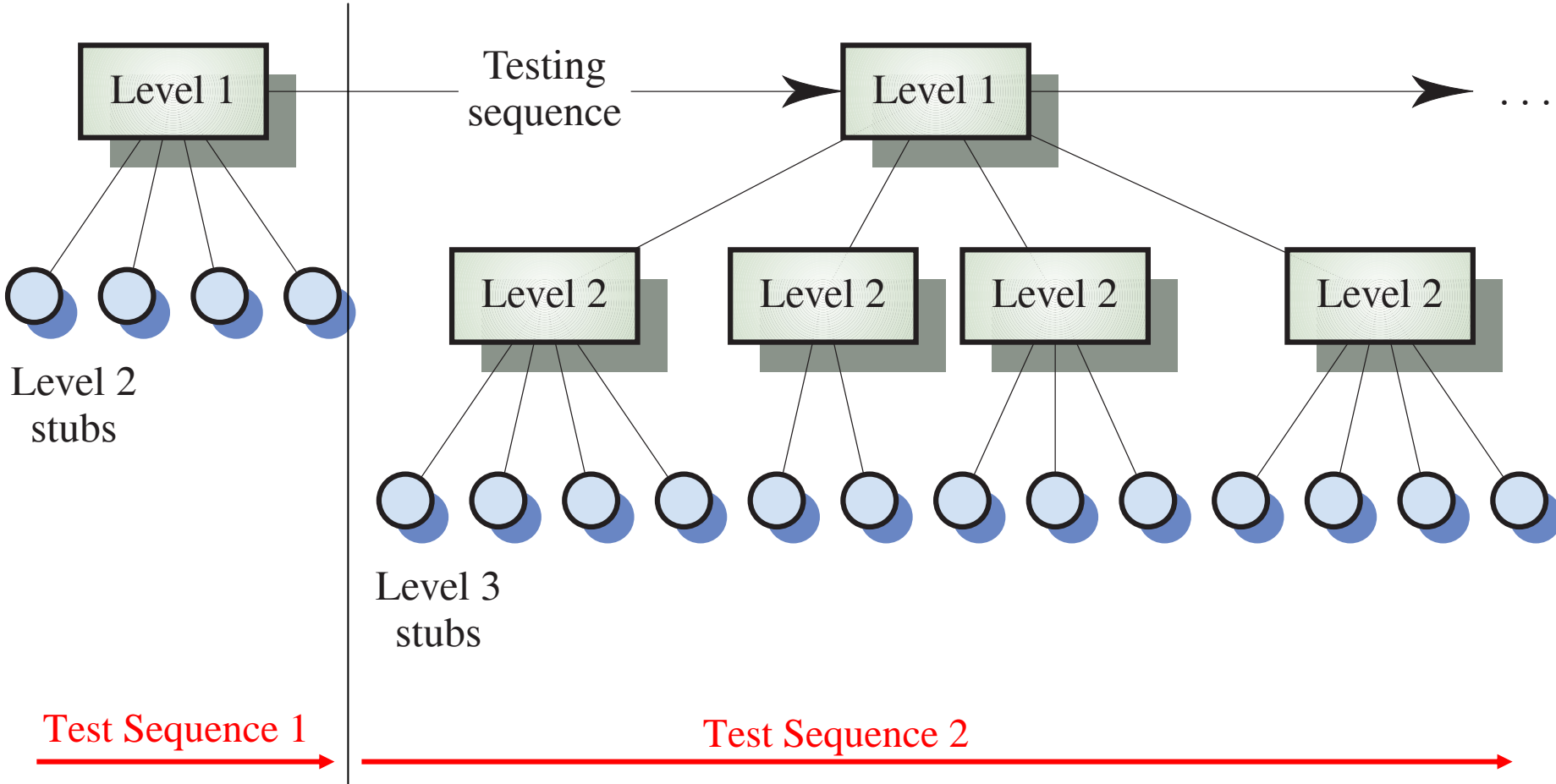

Bottom-up integration testing

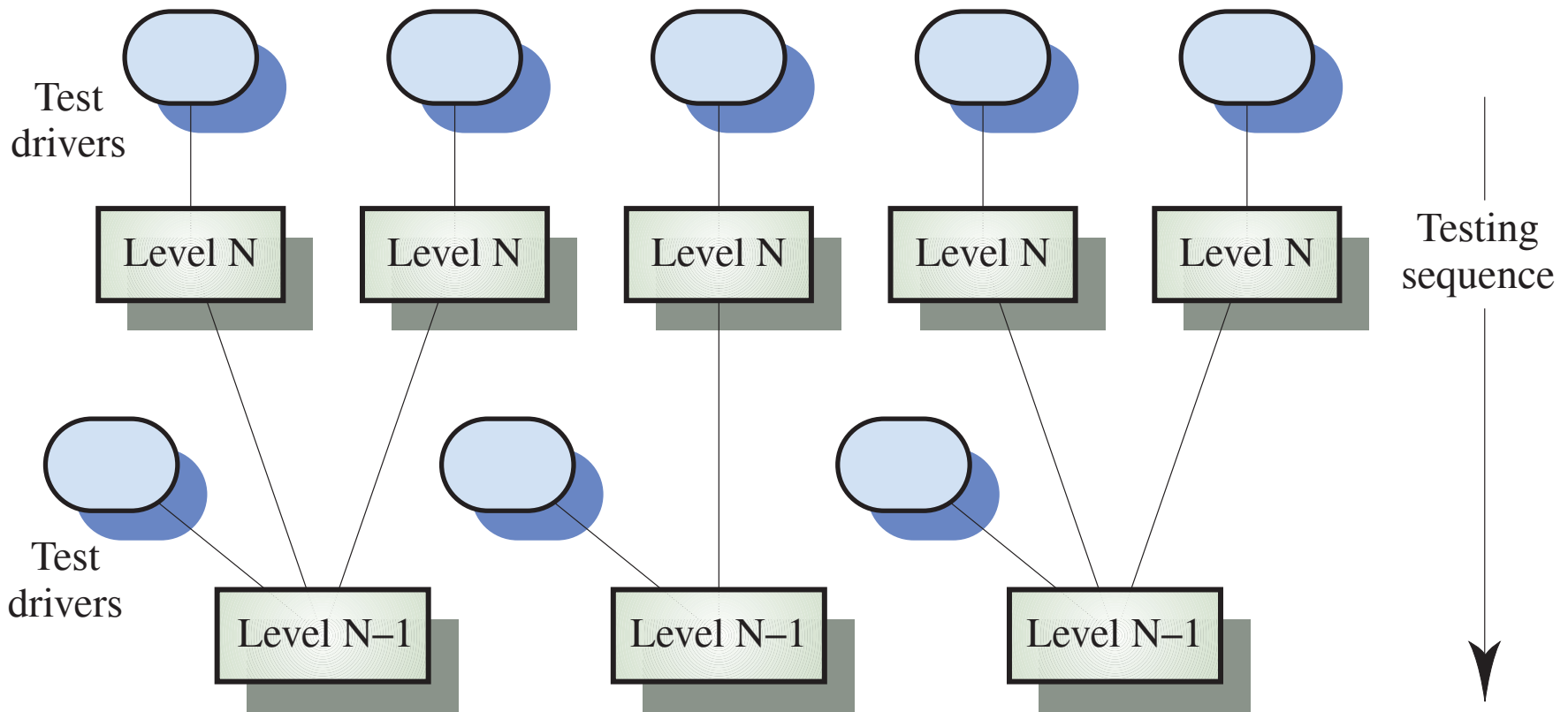

Testing approaches

- Architectural validation
 - ✚ **Top-down integration testing** is better at discovering errors in the system architecture
- System demonstration
 - ✚ **Top-down integration testing** allows a limited demonstration at an early stage in the development
- Test implementation
 - ✚ Often easier with **bottom-up integration testing**

Interface testing

- Takes place when **modules** or **sub-systems** are **integrated** to create larger systems
- Objectives are to detect faults due to interface errors or invalid assumptions about interfaces
- Particularly important for **object-oriented** development as **objects** are defined by their **interfaces**

Interface testing

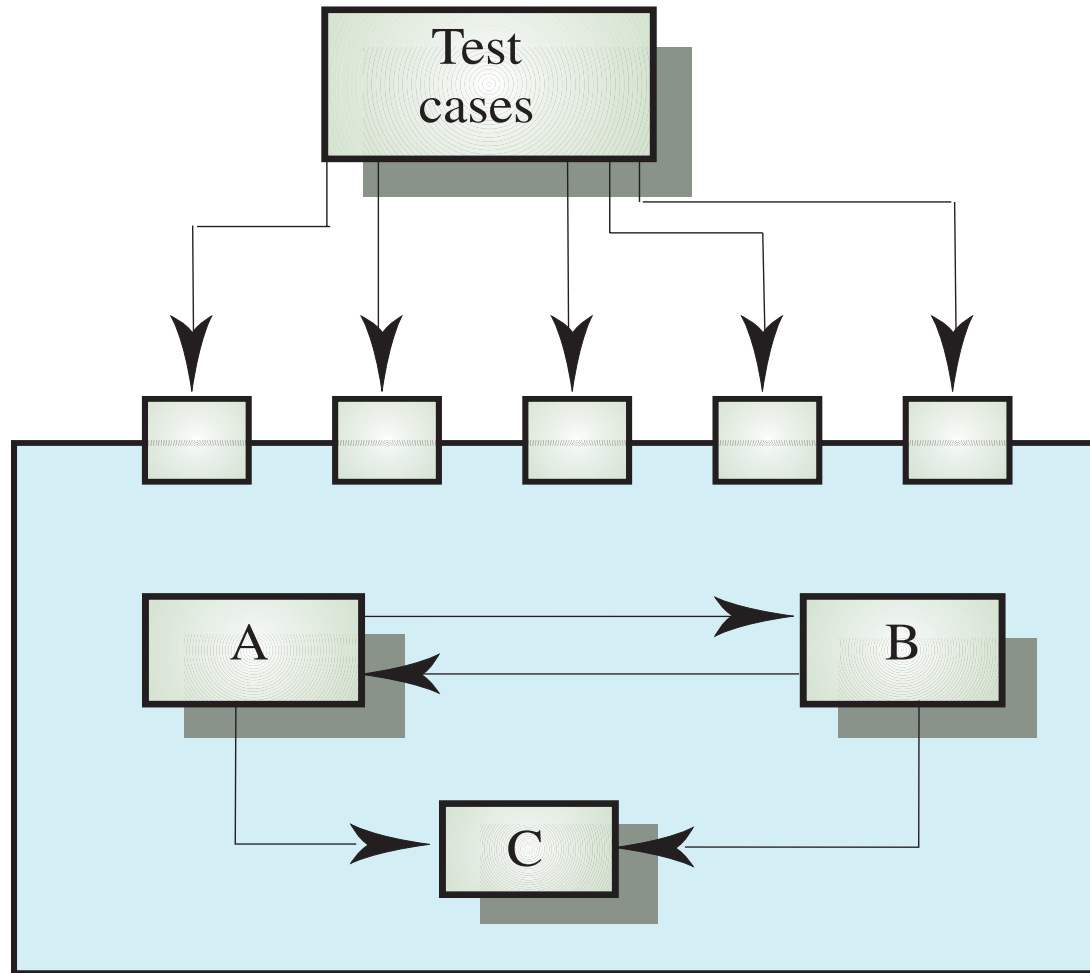

Interfaces types

- Parameter interfaces
 - ✚ Data passed from one procedure to another
- Shared memory interfaces
 - ✚ Block of memory is shared between procedures
- Message passing interfaces
 - ✚ Sub-systems request services from other sub-systems

Interface testing guidelines

- Design tests so that parameters to a called procedure are at the **extreme ends** of their ranges
- Use **stress testing** in message passing systems

Stress testing

- Exercises the system **beyond its maximum design load**.
- Stressing the system often causes defects to come to light
- Stress testing failure behaviour..
 - ✚ Systems **should not fail catastrophically**.
 - ✚ Stress testing checks for unacceptable loss of service or data
- Particularly relevant to **distributed systems** which can exhibit severe degradation as a **network becomes overloaded**

Object-oriented (OO) testing

- The components to be tested are object **classes** that are instantiated as objects

Object-oriented testing:

Testing levels

- Testing **operations (methods)** associated with objects

Remember: XP Unit Testing by developers on implemented operations (methods)

HardDisk
+modelName
+capacity
+producer
...
+read()
+write()
-adjustHeads()
...

- Testing object classes
- Testing **clusters of cooperating objects**
- Testing the **complete OO** system

Object class testing

- Complete test coverage of a class involves:
 - ✚ Testing all **operations** (methods “implemented operation”) associated with an object
 - ✚ Setting and interrogating all object **attributes**
 - ✚ (Recall: XP Unit testing for all methods and attributes of a class)
- **Inheritance makes it more difficult** to design object class tests
 - ✚ the information to be tested is **not localised**

Automated testing

- Important XP practice (See Shodan metrics)
- Highly combined with Continuous Integration practice
- In addition to Application code
 - ✚ Write Test code to automate testing
- Disadvantage:
 - ✚ Extra Cost for the extra code to automate testing
 - ✚ “Testing code” vs Application code
- Advantages:
 - ✚ Easy – just press a button
 - ✚ Fast
 - ✚ Higher quality guaranteed
- Frameworks
 - ✚ JUnit & NUnit XUnit

Key points

- Test parts of a system which are commonly used rather than those which are rarely executed
- Equivalence partitions are sets of test cases where the program should behave in an equivalent way
- Black-box testing is based on the system specification
- Structural testing identifies test cases which cause all paths through the program to be executed

Key points

- Test coverage measures ensure that all statements have been executed at least once.
- Interface defects arise because of specification misreading, misunderstanding, errors or invalid timing assumptions
- To test object classes, test all operations, attributes and states
- Integrate object-oriented systems around clusters of objects