

CBAEL : SOFTWARE FOR STATTIC / DYNAMIC ANALYSIS, DESIGN AND OPTIMIZATION OF STRUCTURES

Abdelhamid Charif¹

*1: Professor, Civil Engineering Department, King Saud University, Riyadh.
Email : acharif@ksu.edu.sa*

ABSTRACT

This paper describes a professional software for static / dynamic analysis, design and optimization of structures according to Algerian and French codes of practice. The Saudi reinforced concrete and seismic codes of practice are currently being implemented.

The software has been developed in Windows environment using the visual programming technology. It has a friendly graphical user interface for pre and post processing and uses most modern numerical techniques.

The graphical pre processor offers many finite element mesh generation schemes including the active front and Delaunay techniques as well as an automatic node renumbering algorithm minimizing the matrix profile.

The current version contains nine modules monitored by a main program and sharing many common resources.

Key Words: *Software, Structures, Analysis, Design, Finite Element, Graphical Interface.*

المخلص

هذا البحث يخص برنامج إعلام آلي لتحليل و تصميم الإنشاءات حسب القوانين التقنية الجزائرية والفرنسية. القوانين المعمول بها بالمملكة السعودية هي الآن بصدد الإدماج. تم تطوير البرنامج في نظام ويندوز باستعمال أحدث تقنيات البرمجة.

يحتوي البرنامج على عدة امتيازات لرسوم هندسية لإدخال المعطيات و تحليل النتائج. مرحلة النمذجة تحتوي على عدة تقنيات التجزئة الآلية لطريقة العناصر المحددة مع إعادة ترقيم آلية للنقاط. يحتوي البرنامج حالياً على تسع وحدات مسيرة ببرنامج رئيسي وتستعمل عدة خدمات مشتركة.

1. INTRODUCTION

CBAEL is a professional software for static and dynamic analysis, design and optimization of structures according to Algerian and French reinforced concrete and seismic codes CBA 93, BAEL 91 and RPA 99 [CGS 1993, 1995, 2000; CSTB 1990,1991]. The tool has been under development for many years with the visual programming technology under Windows 95/98/2000/NT environment and has a powerful graphical interface for pre and post processing. Saudi and American codes are currently being integrated. The software has already been presented in previous occasions [Charif, 1998, 1999]. The present paper describes the various modules of the software including recent extensions and updating relative to RC structural optimization by reanalysis, analysis of flows through porous media as well as the integration of the latest Algerian Seismic code specifications.

2. RESOURCES OF CBAEL

Version 7 of CBAEL contains nine modules driven by a principal program and sharing many common resources. Most recent numerical analysis concepts are implemented in the software :

- **Finite elements** : Use of robust elements - Automatic mesh generation - Optimal node renumbering - Profile solver – Stress nodal projection – Dynamic memory management
- **Graphics**: Friendly graphical environment – Plane / isometric graphical contours – Animation – Hidden surface algorithm – Pre and post processing.
- **Reinforced concrete** : Controlled intersection method for equilibrium equation solution – Integrated code prescriptions – ULS (Ultimate Limit State) and SLS (Service Limit State) design with many steel layers and various section shapes – Strain and stress diagrams – Axial force / bending moment interaction curves – Bending moment / curvature diagrams.

3. REINFORCED CONCRETE DESIGN MODULES

The reinforced concrete module is a powerful workshop where the user can carry various design and checking calculations for various types of sections in Ultimate and Service Limit States. The required steel could be determined as optimal, symmetric or with an imposed upper steel area. Second order effects can be accounted for in case of compressive axial forces in ULS. The graphical post-processor delivers the number of rebars for various diameters and the diagrams of strains and stresses (Figure 1). Axial force – moment interaction curves can be obtained in ULS or SLS for various forms of sections of plain concrete or reinforced with many (up to 200) steel layers. The tool delivers both the limit curve as well as the zones where the section is either entirely in compression or entirely in tension. This option is very useful for the design under several combinations of bending moments with axial forces as the worst case is never obvious. The user can also obtain the moment – curvature diagram for any level of the axial force. These curves give a quantified appreciation of the section ductility. Fig. 2 illustrates the analysis results of a box section with four steel layers and highlights the reduction in ductility (curvature) with a higher value of the axial force.

The shear force and torque module allows the user to determine transverse reinforcement and their spacing while checking the ultimate shear stress according to code specifications. The bars may be horizontal, vertical or inclined.

The shear wall module deals with the design of the walls according to their specific Algerian and French code regulations. Original algorithms are used to determine the steel reinforcement in many layers with a graphical output (Figure 3).

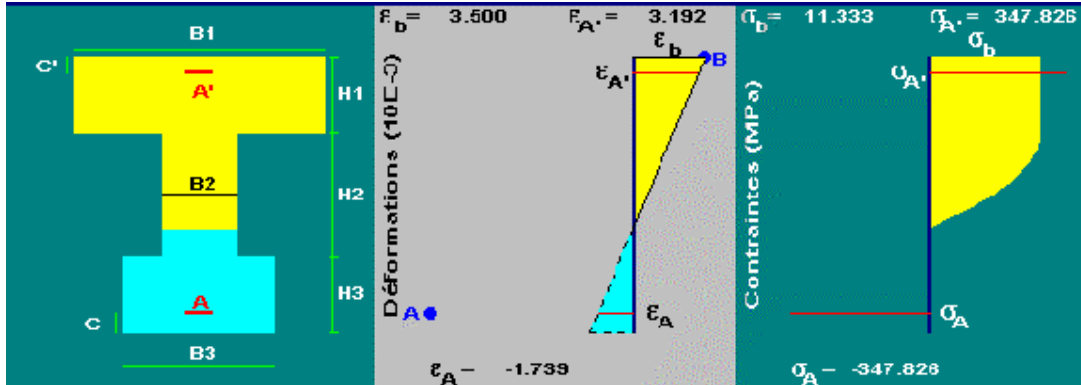

Figure 1 : RC design in ULS (Ultimate Limit State)

With the footing module, the user can carry out the design of isolated footings under columns as well as continuous foundations under walls. The software delivers both the minimum dimensions of the footings and the steel reinforcement. The user may keep the software dimensions or use his provided that in the latter the soil pressure does not exceed the limit. The post processor delivers the soil pressure distribution and reinforcement detailing (Figure 4).

The retaining wall module is used to analyze and design this type of structures. Soil pressure (single or multi layered soil) is determined via Rankine theory with a possible phreatic water layer. The software checks the stability of the retaining wall and determines the internal forces and the reinforcement along the members with a graphical output (Figure 5).

4. FINITE ELEMENT ANALYSIS MODULES

Beam and plate modules allow the user to analyze and design beam and thin/thick plates on rigid supports or resting on continuous elastic foundations. Beams of various sections, slabs and mats of any geometry can thus be analyzed and designed. The plates may have stiffeners (embedded beams). Surface, line and concentrated loadings may all be applied. Beam section, plate thickness and soil stiffness may be constant or variable. Flexible and rigid foundation response may be obtained by parametric analysis (Figure 6). A powerful graphical pre processor [Charif, 1998b, 1999] allows automatic finite element modeling with an optimal internal node re-numbering scheme minimizing the matrix profile. The post processor produces graphical output under various forms including parametric isometric views as well as the reinforced concrete design (Figures 7-8) The two way reinforcement for plates may be obtained along the original orthogonal coordinate system or along new skew axes by using the Wood-Armer criterion [Wood 1968, Armer 1968]. It is also possible to obtain influence lines and influence surfaces under moving loads.

Analysis and design of framed structures under many types of loadings and combinations is also possible. The tool offers many modeling options such as internal hinges, rigid end offsets, rigid diaphragm as well as a powerful user graphical interface (Figure 9) for pre and post processing. Automatic successive re-analyses allow the user to optimize the structure by correcting the member dimensions until all code requirements are met. Members for which the steel reinforcement is greater than the code maximal limit are considered under designed and automatic or user-controlled increase in dimensions is invoked. Members for which the code minimum reinforcement is used can be considered as over designed and automatic or user-controlled reduction in dimensions may be activated. The automatic re-analysis option is not a mathematical optimization technique but it allows the user to cater for both structural safety and economy.

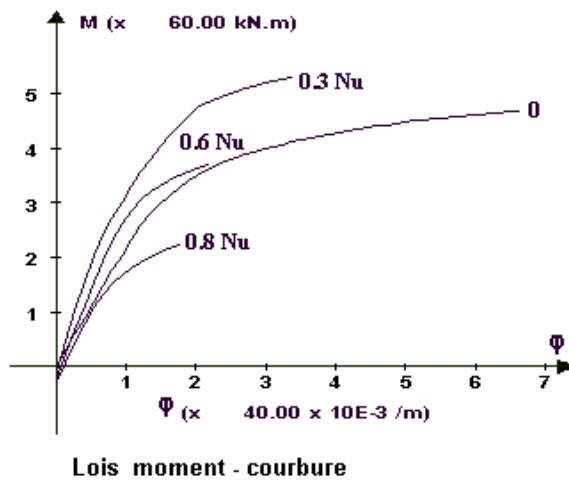
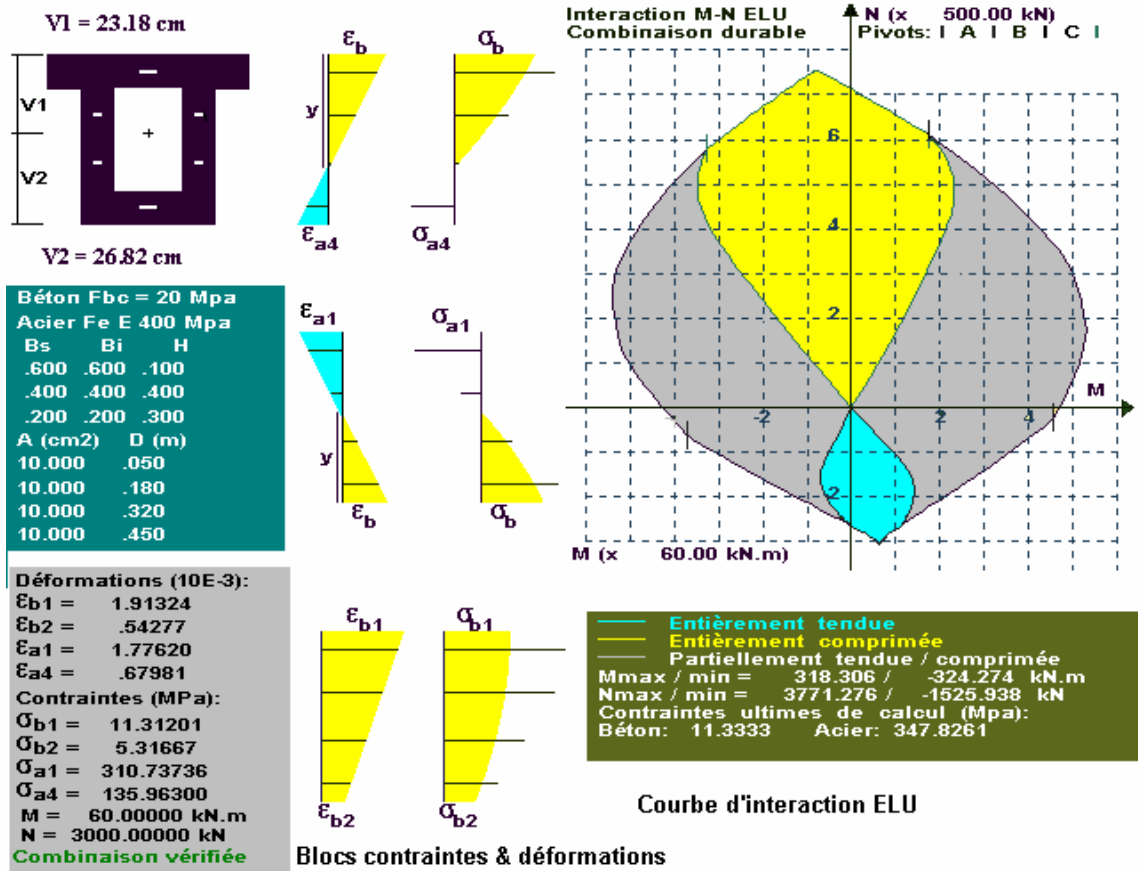
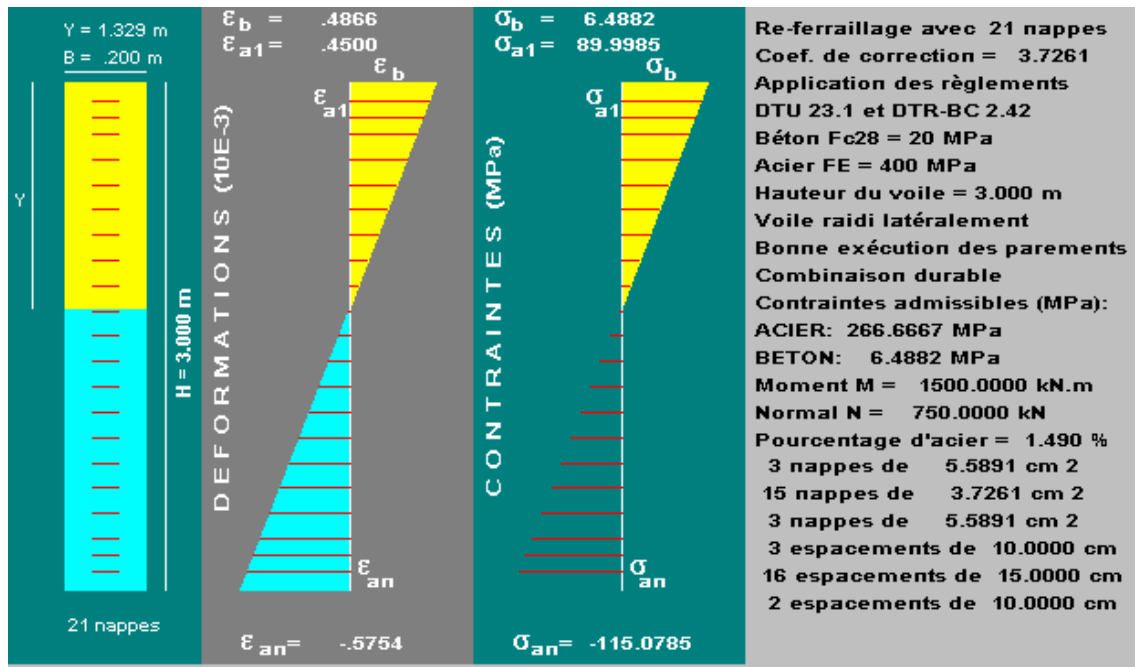

Fig.2: Analysis of a box section with four steel layers



Ferraillage des voiles avec des nappes et espacements quelconques

ANALYSE DES VOILES

Dimensions de la section (m)
B (m) H (m)

Nbre nappes d'acier (0-150)
Nap = C' (m)

Sections d'acier et leurs positions		Esp.(m)	
A (cm ²)	Nrep.		Nrep.
1.5	3	0.10	3
1.0	15	0.15	16
1.5	3	0.10	2

Classe de béton fc28 (MPa)
 16 MPa (Dosage faible)
 20 MPa (Dosage 300-325)
 25 Mpa (Dosage 350-375)
 30 MPa (A justifier)

Classe d'acier Fe E (MPa)
 Fe E 215 (Acier doux)
 Fe E 235 (Acier doux)
 Fe E 400 (H.A.)
 Fe E 500 (H.A.)

CONTRAINTES ADMISSIBLES
 Application des règlements DTU 23.1 et DTR-BC 2.2
 Pas d'application de la réglementation en vigueur

Hauteur du voile (m) =

Voile raidi latéralement ? Oui Non
 Bonne qualité d'exécution ? Oui Non
 Type de combinaison: Durable Accidentelle

Donnez les contraintes admissibles (MPa)
 Béton = Acier =

Sollicitations M et N
 M (kN.m) =
 N (kN) =

Type de ferraillage
 Avec A' donnée
 Symétrique A' (cm²)
 Normal

Figure 3: RC design of a shear wall with many steel layers (Dialog box and results)

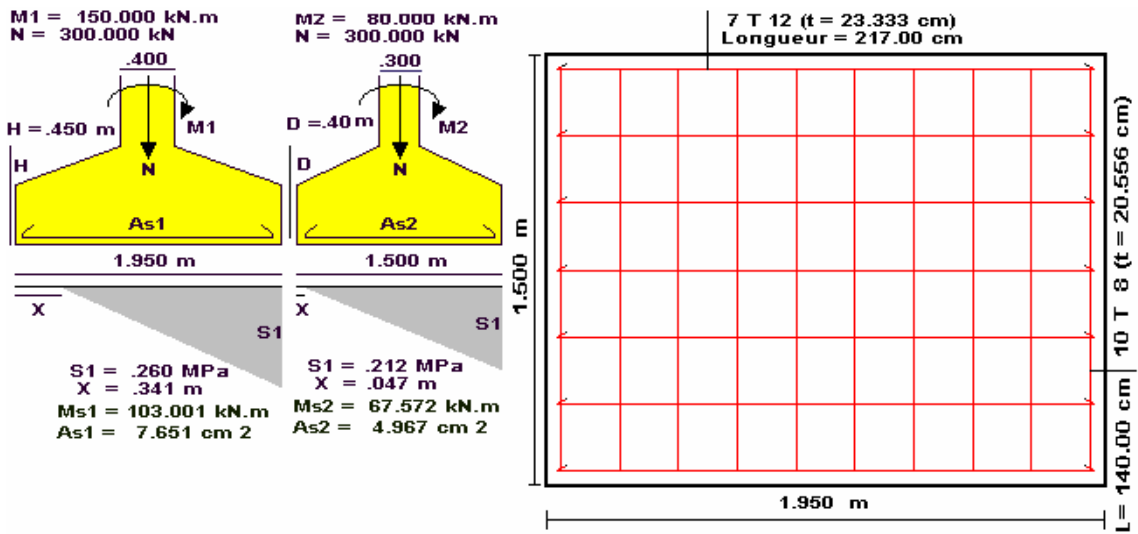

**Etude des semelles
et plans de ferrailage**

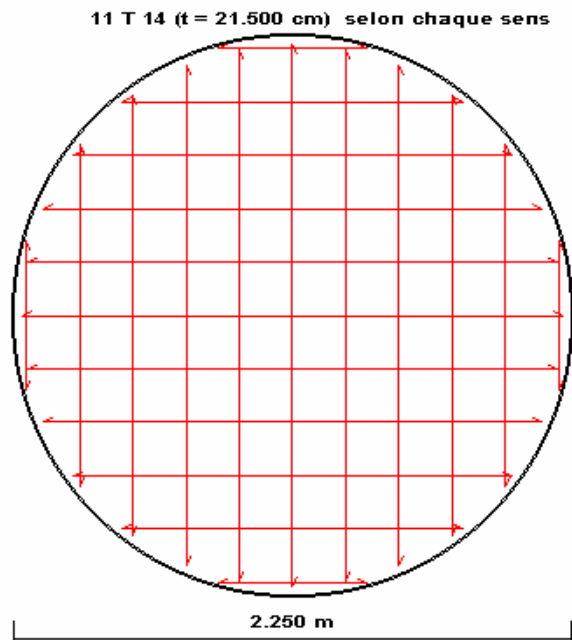
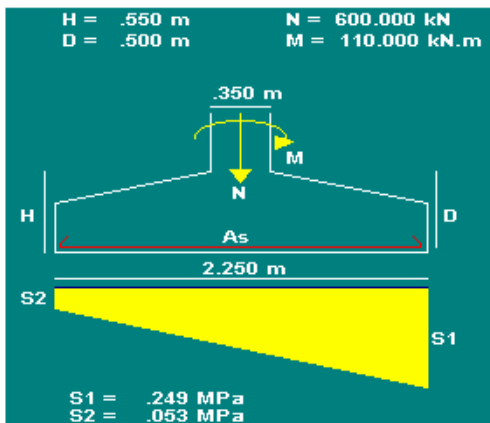
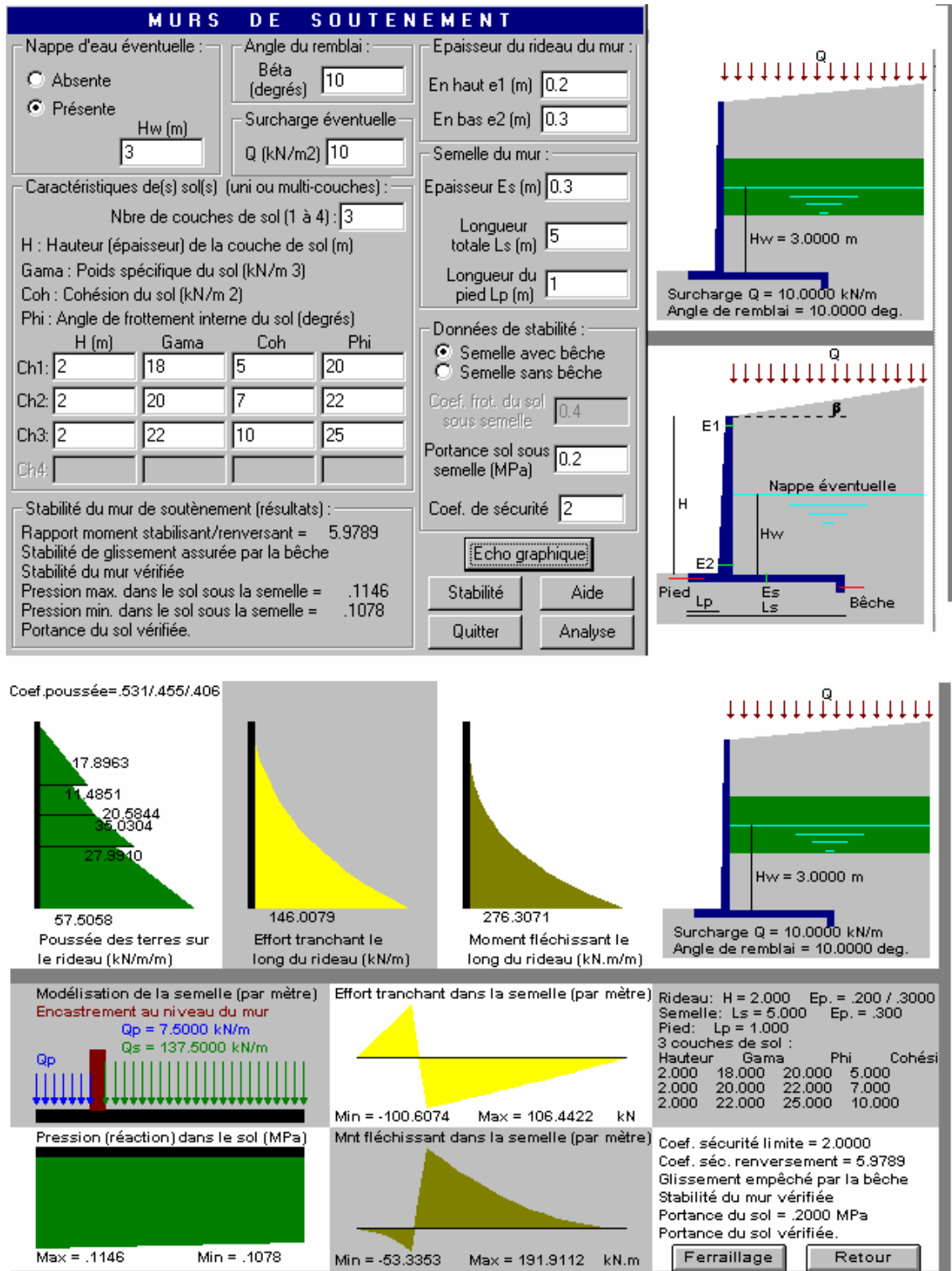

Fig.4: Design of footings

Figure 5: Analysis and design of retaining walls



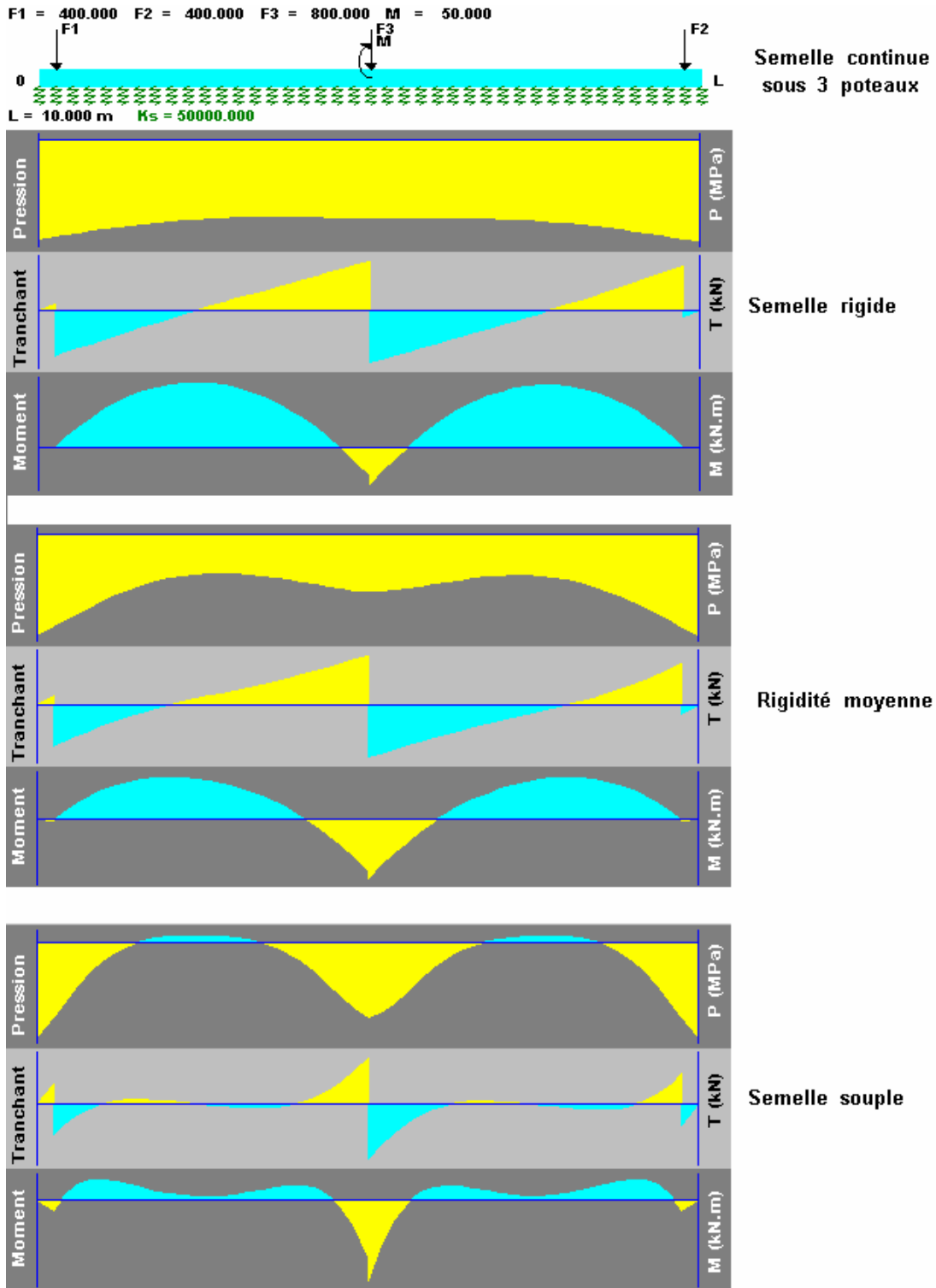
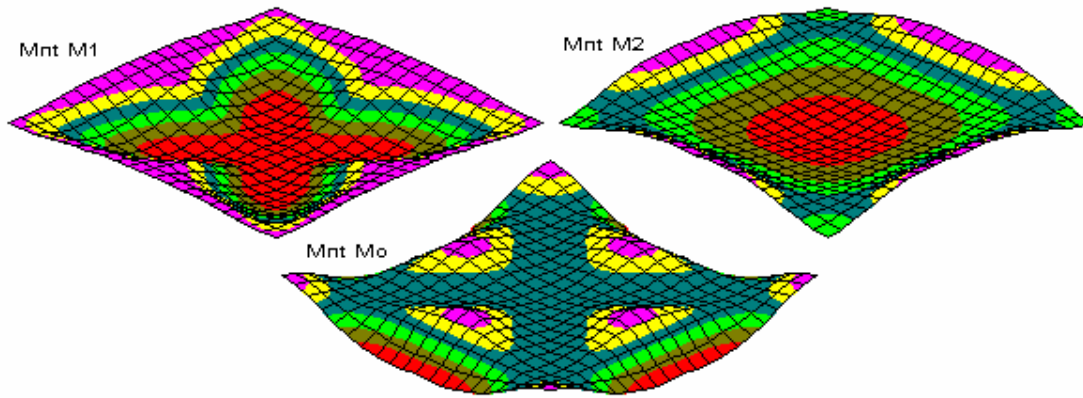
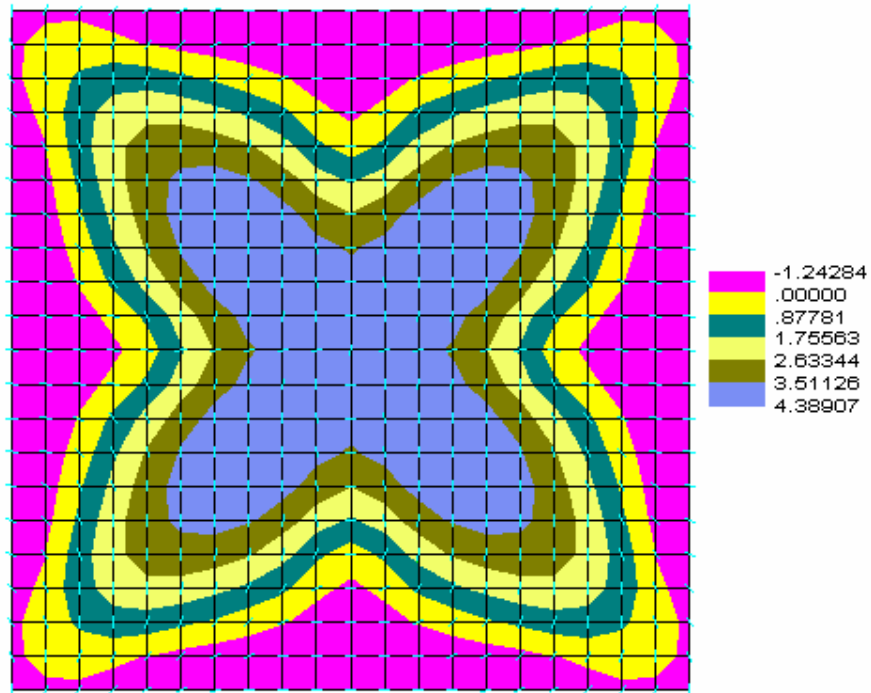

Figure 6: Analysis and design of a continuous beam foundation on elastic soil



Moments principaux et moment de Von Mises



Mnt Principal M1 (kN.m/m)
 Min / Max = -1.24284 / 4.38907
 — Directions principales

Contours et directions principales de M1

Figure 7 : Analysis and design of a slab

FERRAILLAGE DE LA PLAQUE



Méthode de Wood - Armer

FERRAILLAGE BI-DIRECTIONNEL DES PLAQUES		
Classe de béton f_{c28} (MPa) <input type="radio"/> 16 MPa (Dosage faible) <input checked="" type="radio"/> 20 MPa (Dosage 300-325) <input type="radio"/> 25 MPa (Dosage 350-375) <input type="radio"/> 30 MPa (A justifier)	Classe d'acier Fe E (MPa) <input type="radio"/> Fe E 215 (Acier doux) <input type="radio"/> Fe E 235 (Acier doux) <input checked="" type="radio"/> Fe E 400 (H.A.) <input type="radio"/> Fe E 500 (H.A.)	Le ferrailage de la plaque aux ELU-ELS peut être obtenu aux sections critiques ou ailleurs (en cliquant sur le noeud). Les armatures sont évaluées pour équilibrer les moments résultants $M_x + M_{xy}$ et $M_y + M_{xy}$ selon les axes de référence X et Y ou selon des axes quelconques X' et Y' perpendiculaires ou non (plaques biaisées). Pour des axes orthogonaux et si M_x et M_y sont de même signe, la combinaison adoptée est $M + \text{abs}(M_{xy})$ pour les moments positifs et $M - \text{abs}(M_{xy})$ pour les moments négatifs. Pour des axes biaisés ou si M_x et M_y sont de signes opposés, la combinaison est dérivée du critère général de Wood-Armer.
Type d'état limite étudié : <input checked="" type="radio"/> E.L.U. <input type="radio"/> E.L.S.	Type de combinaison <input checked="" type="radio"/> Durable <input type="radio"/> Accidentelle <input type="radio"/> Très nuisible	
Axes de ferrailage <input checked="" type="radio"/> Axes de référence X et Y <input type="radio"/> Nouveaux axes X' et Y'	Enrobages (m) C (m) : <input type="text" value="0.03"/> C' (m) : <input type="text" value="0.03"/>	
Angle X'X' (deg) : <input type="text"/>	<input type="button" value="OK"/> <input type="button" value="Annuler"/>	
Angle X'Y' (deg) : <input type="text"/>		

Efforts dans les raidisseurs (poutres)

T (kN)

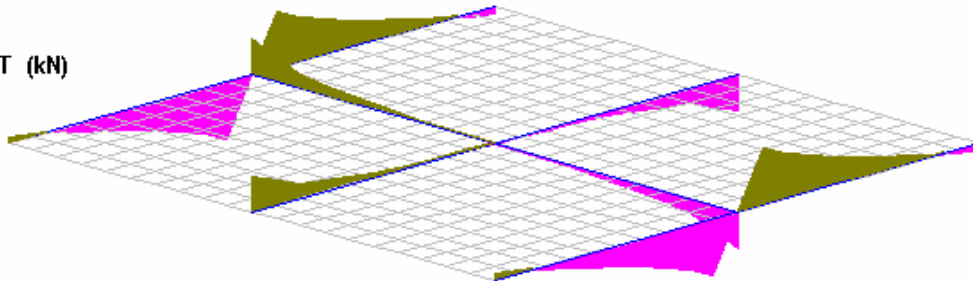

M (kN.m)

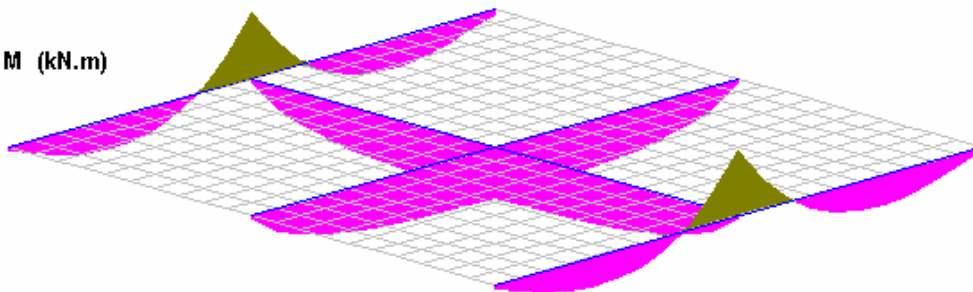

Figure 8 : Analysis and design of a stiffened plate – Internal forces in embedded beams

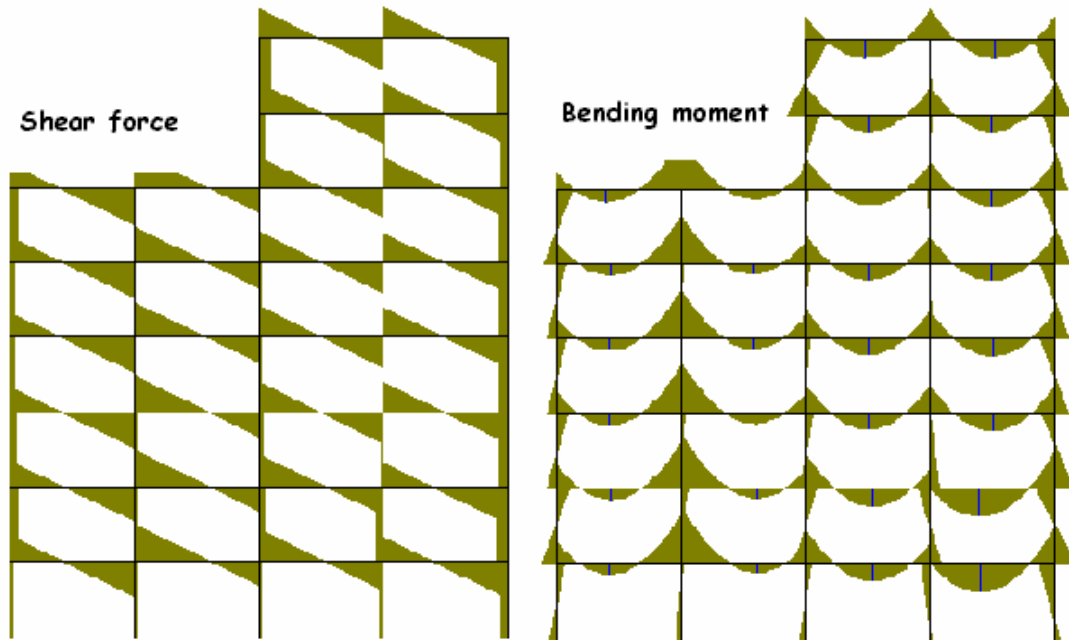

Figure 9 : Analysis and design of framed structures

5. FINITE ELEMENT ANALYSIS OF FLOW THROUGH POROUS MEDIA

This module is for the analysis of confined or unconfined flows through porous media with graphical pre and post processing facilities. Plane and axi-symmetric models can be used. In unconfined flows, the software allows tracking of the free surface and seep surface without resorting to geometrical mesh correction. Complex geometries may thus be studied. A powerful nonlinear algorithm combining elastic-plastic methods and updating of boundary conditions is used. Contours of potential and stream line functions as well as the pressure are all produced by the post processor (Figure 10). Flows through and below dams, around and towards wells can all be analyzed and the exploitation of aquifers may thus be rationalized.

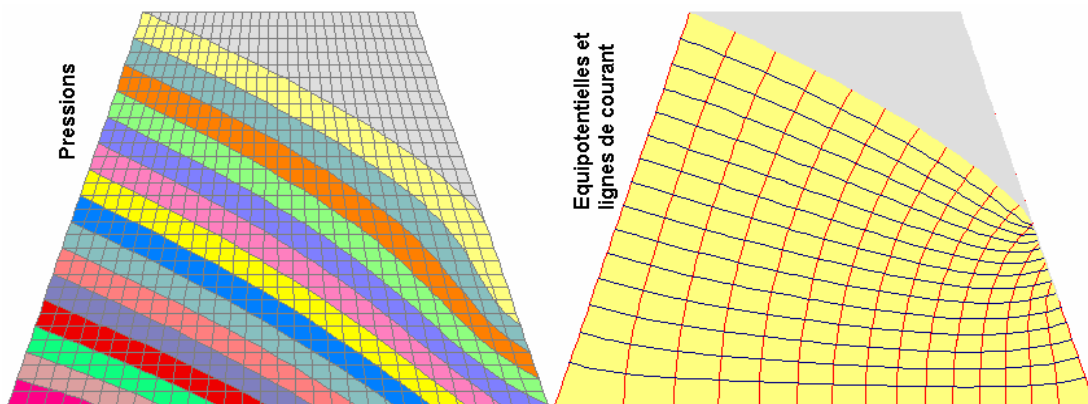

Figure 8: Isovaleurs des résultats

Figure 10 : Analysis of an unconfined flow in an earth dam

6. SEISMIC STRUCTURAL ANALYSIS

With this module it is possible to carry out a dynamic and seismic structural analysis according to the Algerian seismic code RPA 99. Many 2d and 3d modeling options are available with various modal and seismic direction combinations. All code regulations including zoning, the spectrum and the accidental torsion effects are integrated and the post processor delivers modal shapes with animation, modal forces, resulting displacements and forces and various code checking (Figure 11).

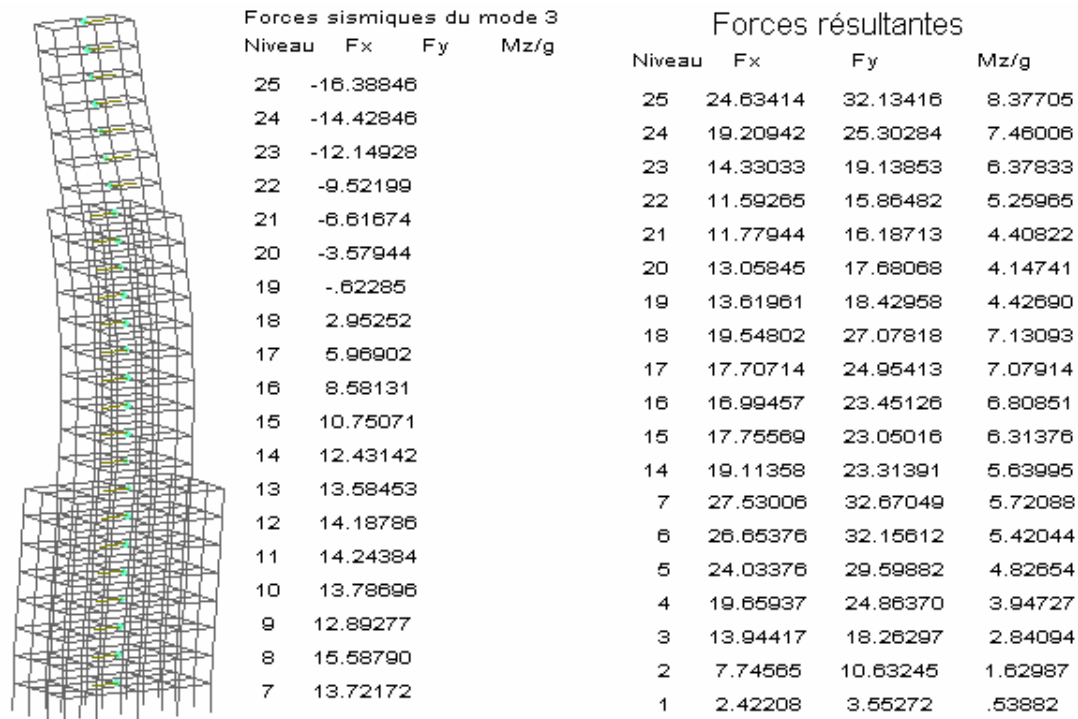

Fig.9: Forces du mode 3 et forces résultantes

7. CONCLUSIONS

CBAEL is the only professional software integrating all Algerian code specifications. It has been used by many Algerian university and industry professionals. The Saudi code specifications are currently being integrated. To the author's knowledge it is the only serious attempt to develop such a software in Arab countries.

REFERENCES

- Armer G.S.T., 1968, "Correspondence on reference of Wood", *Concrete*, Vol. 2, No 8, pp.319-320.
- Charif A., 1998a, "CBAEL logiciel d'analyse et ferrailage des structures selon les règlements." *1^{er} Colloque Maghrébin de Génie Civil*, Biskra 16-17 Novembre 1998, pp.13-23.
- Charif A., 1998b, "Pré-processeur graphique de modélisation par éléments finis." *1^{er} Colloque Maghrébin de Génie Civil*, Biskra 16-17 Novembre 1998, pp.75-85.
- Charif A., 1999, "Graphical pre-processor for finite and infinite element modelling." *Second Jordanian Civil Engineering Conference*, Amman 16-17 November 1999.
- C.S.T.B., 1990, "Règles de calcul des parois et murs en béton banché", DTU 23.1
- C.G.S., 1993, "Règles de conception et de calcul des structures en béton armé CBA 93"
- C.G.S., 1995, "Règles de conception et de calcul des parois et murs en béton banché", DTR-BC 2.42
- C.S.T.B., 1991, "Règles techniques de conception et de calcul des ouvrages et constructions en béton armé suivant la méthode des états limites BAEL 91"
- C.G.S., 2000, "Règles parasismiques algériennes RPA 99", OPU 2000.
- Wood R.H., 1968, "The reinforcement of slabs in accordance with field of moments" *Concrete Magazine*, Vol. 2, No 2, pp.69-75.