

سابك  
SABIC



PARCI  
معهد الأمير عبد الله للبحوث والدراسات الاستشارية  
PRINCE ABDULLAH RESEARCH & CONSULTING INSTITUTE

نموذج تعاون ناجح

مع

شركة سابك

مؤتمر الشراكة بين الجامعات والقطاع الخاص

1426/3/3



PARCI

معهد الأمير عبد الله للبحوث والدراسات الاستشارية  
PRINCE ABDULLAH RESEARCH & CONSULTING INSTITUTE

## التعاون الجديد مع شركة سابك

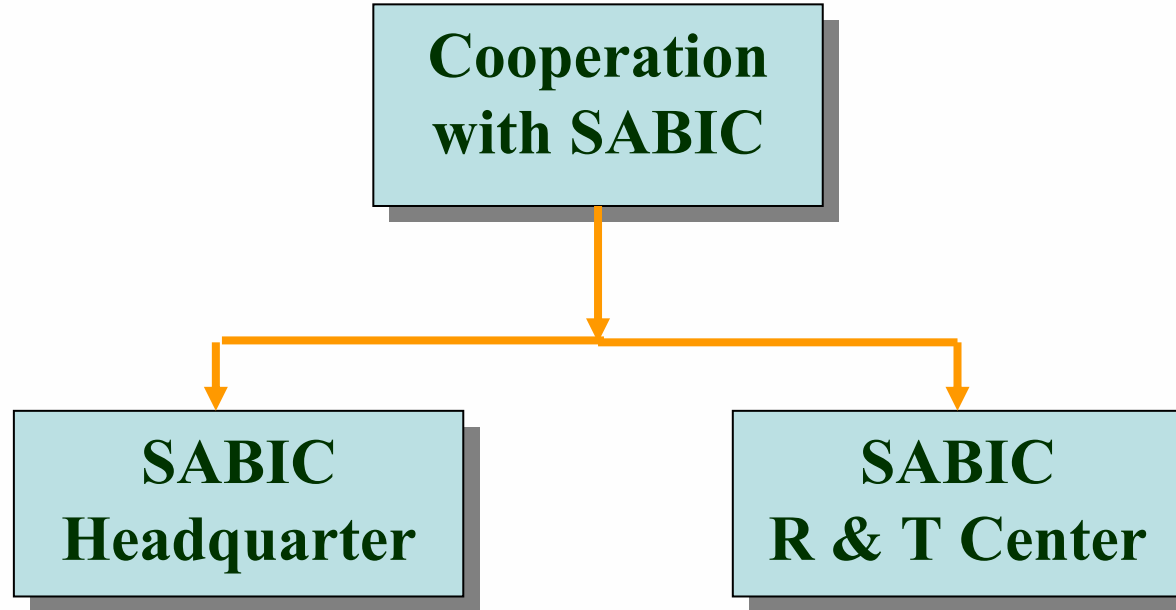

عمل الدراسات والاستشارات الهندسية والفنية والاقتصادية  
والتسويقية للمشاريع الاستثمارية المطروحة من قبل شركة  
”سابك“ للقطاع الخاص



PARCI

معهد الأمير عبد الله للبحوث والدراسات الاستشارية  
PRINCE ABDULLAH RESEARCH & CONSULTING INSTITUTE

## بداية التعاون الجديد

” فإننا نرغب في معهد الأمير عبدالله للبحوث والدراسات الاستشارية بجامعة الملك سعود، توسيع أفق هذا التعاون لما نجده من توفر فضاءات أوسع للتعاون بين الشركة والمعهد بما يعود بالخير -إن شاء الله- على الطرفين..“  
معهد الأمير عبد الله للبحوث والدراسات الاستشارية

” وإذ أشيد بالإمكانات الكبيرة التي تجعل هذا المعهد صرحا من الصروح العلمية الحضارية في هذا الوطن الكريم.. أعرب لكم عن بالغ تقديري لمنظومة التعاون المثمر القائمة بين المعهد وسابك منذ إنشائه..“

الرئيس التنفيذي لشركة سابك

# SABIC PRODUCTS



PARCI

معهد الأمير عبد الله للبحوث والدراسات الاستشارية  
PRINCE ABDULLAH RESEARCH & CONSULTING INSTITUTE

Product	Application	Subsidiary
Ethylene	Ethylene is the premier building block of the petrochemicals industry. It is used in the production of polyethylene, ethylene dichloride, ethanol, styrene, glycols and many other products.	<ul style="list-style-type: none"> <li>- Saudi Petrochemical Company (SADAF)</li> <li>- Arabian Petrochemical Company (KEMYA)</li> <li>- Saudi Yanbu Petrochemical Company (YANPET)</li> </ul>
Propylene	Propylene, an important feedstock for the petrochemical industry, is used in the production of polypropylene, acrylonitrile, propylene glycols, cumene, butyraldehydes, acrolein and other products.	<ul style="list-style-type: none"> <li>- Saudi Yanbu Petrochemical Company (YANPET)</li> <li>- Arabian Petrochemical Company (KEMYA)</li> </ul>
Methanol	Formaldehyde production is the largest market for methanol, followed by the fast growing market for MTBE. It is also used to produce acetic acid, fuels, solvents and methyle derivatives.	<ul style="list-style-type: none"> <li>- Saudi Methanol Company (AR-RAZI)</li> <li>- National Methanol Company (IBN SINA)</li> <li>- Gulf Petrochemical Industries Company (GPIC)</li> </ul>

# SABIC PRODUCTS



PARCI

معهد الأمير عبد الله للبحوث والدراسات الاستشارية  
PRINCE ABDULLAH RESEARCH & CONSULTING INSTITUTE

Benzene	benzene and ethylene are used to produce styrene, from which polystyrene is made. It is also used to produce cyclohexane, a precursor to caprolactam, which is used to produce nylon. Well known commodity chemicals like polystyrene and nylon are subsequently used to manufacture everyday items including clothing, paints, computer casings and packaging.	- Arabian Industrial Fibers Company (IBN RUSHD)
Paraxylene	Paraxylene is used primarily as a feedstock for the manufacture of purified terephthalic acid (PTA), the principal raw material to produce most polyester.	- Arabian Industrial Fibers Company (IBN RUSHD)
MTBE	MTBE is used mainly as a high-octane gasoline-blending component. It replaces lead compounds and provides good anti-knock characteristics.	- Saudi European Petrochemical Company (IBN ZAHR) - National Methanol Company (IBN SINA) - Saudi Petrochemical Company (SADAF)
Styrene	Poly styrene production	- Saudi Petrochemical Company (SADAF)

# SABIC PRODUCTS



PARCI

معهد الأمير عبد الله للبحوث والدراسات الاستشارية  
PRINCE ABDULLAH RESEARCH & CONSULTING INSTITUTE

<p>Crude Industrial Ethanol (CIE)</p>	<p>Chemical grade ethanol can be oxidized to acetaldehyde and acetic acid. It is also used in the synthesis of many useful ethyl esters and various ethyl derivatives. The solvent grade is useful in the formulation of many perfumes, pharmaceuticals, cosmetics, and organic solutions.</p>	<p>- Saudi Petrochemical Company (SADAF)</p>
<p>Butadiene</p>	<p>One major use of Butadiene has been in the making of synthetic rubber (Styrene-Butadiene and Nitrile Butadiene rubbers, to a large extent, CIS-Polybutadiene is also an extender and substitute for rubber, and polymerizations trans-polybutadiene is a type of rubber with unusual properties). Butadiene is also used extensively for various polymerizations for plastics manufacturing. Copolymers with high proportions of styrene have found applications such as stiffening resins for rubber, in water-base and other paints, and in high impact plastic. Butadiene also serves as a starting material for nylon 66 (adiponitrile) and an ingredient in rocket fuel (Butadiene - Acrylonitrile polymer).</p>	<p>- Arabian Petrochemical Company (KEMYA) - Saudi Yanbu Petrochemical Company (YANPET)</p>

# SABIC PRODUCTS



PARCI

معهد الأمير عبد الله للبحوث والدراسات الاستشارية  
PRINCE ABDULLAH RESEARCH & CONSULTING INSTITUTE

Butene-1	Butene-1 can be produced directly from ethylene as CP 99.0%. It is used as a copolymer in polyethylene alkylate gasoline, polybutenes, butadiene; as intermediates for C4 and C5 aldehydes, alcohols and other derivatives; and in the production of maleic anhydride by catalytic oxidation.	-Arabian Petrochemical Company (KEMYA)
Mono Ethylene Glycol (MEG)	MEG is mainly used in the production of Polyester, Polyethylene Terephthalate (PET) and antifreeze solutions. It is an important dehydrating agent, and an industrial solvent.	<ul style="list-style-type: none"> <li>- Saudi Yanbu Petrochemical Company (YANPET)</li> <li>- Eastern Petrochemical Company (SHARQ)</li> </ul>
Ethylene Dichloride (EDC)	About 95% of EDC production is converted to VCM for PVC production. Some is used as an organic solvent, as a fumigant, and in the chemical synthesis of various products	- Saudi Petrochemical Company (SADAF)
PolyEthylene (LDPE, LLDPE, HDPE)	Grades are specifically designed to meet a variety of injection molding, rotational molding, blow molding and film extrusion applications and end-uses.	<ul style="list-style-type: none"> <li>- Al-Jubail Petrochemical Company (KEMYA)</li> <li>- Eastern Petrochemical Company (SHARQ)</li> <li>- Saudi Yanbu Petrochemical Company (YANPET)</li> </ul>

# SABIC PRODUCTS



PARCI

معهد الأمير عبد الله للبحوث والدراسات الاستشارية  
PRINCE ABDULLAH RESEARCH & CONSULTING INSTITUTE

<p>PolyPropylene</p>	<p>Stretched tapes for woven products, carpet backing, industrial and geotextile fabrics, fiber spinning, Oriented (OPP) films, injecting molding of rigid packaging, house wares and closures.</p>	<ul style="list-style-type: none"> <li>- Saudi European Petrochemical Company (IBN ZAHR)</li> <li>- Saudi Yanbu Petrochemical Company (YANPET)</li> </ul>
<p>PolyVinylChloride (PVC)</p>	<p>Applications of suspension grade are Bottles, injection molded parts (pipe fittings), rigid sheets, and film, rigid pipes, and profiles (window frames), wire and cable coating applications, flexible profiles, injection molding of flexible articles, and calendared flexible sheets. Emulsion grade of PVC is used in spread coating.</p>	<ul style="list-style-type: none"> <li>- National Plastics Company (IBN HAYYAN)</li> </ul>
<p>Melamine</p>	<p>is used as an essential component in the manufacture of a wide variety of products including paints, adhesives, decorative laminates, water-resistant chipboard and plywood. It is also used in the formulation of molding powders for the manufacture of electrical components and unbreakable tableware.</p>	<ul style="list-style-type: none"> <li>- Saudi Arabian Fertilizer Company (SAFCO)</li> </ul>

# SABIC PRODUCTS



PARCI

معهد الأمير عبد الله للبحوث والدراسات الاستشارية  
PRINCE ABDULLAH RESEARCH & CONSULTING INSTITUTE

Polyester fibers	Polyester and Melamine include many staple fibers used in textile and carpet manufacture and weaving and knitting, resins used to make bottles, trays and packaging, and melamine adhesives, laminates, surface coatings and molding compounds.	- Arabian Industrial Fibers Company (IBN RUSHD)
Polystyrene	Polystyrenes are used in a wide range of applications, from toys and disposable cutlery to insulation and industrial packaging.	- Arabian Petrochemical Company (KEMYA)
Ammonia and Phosphates	Most of the ammonia produced by SABIC is used as raw material to produce urea, about half a million tons, representing 25 percent of total capacity, goes to the international market mainly Asia.	<ul style="list-style-type: none"> <li>- Saudi Arabian Fertilizer Company (SAFCO)</li> <li>- Al-Jubail Chemical Fertilizer Co. (SAMAD)</li> <li>- Safco Natinoal Chemical Fertilizer Co. (IBN AL- BAYTAR)</li> </ul>
Urea (Fertilizer)	Urea is suitable for all crops across a wide range of environmental conditions.	<ul style="list-style-type: none"> <li>- Saudi Arabian Fertilizer Company (SAFCO)</li> <li>- Al-Jubail Chemical Fertilizer Co. (SAMAD)</li> </ul>



PARCI

معهد الأمير عبد الله للبحوث والدراسات الاستشارية  
PRINCE ABDULLAH RESEARCH & CONSULTING INSTITUTE

## موضوع التعاون

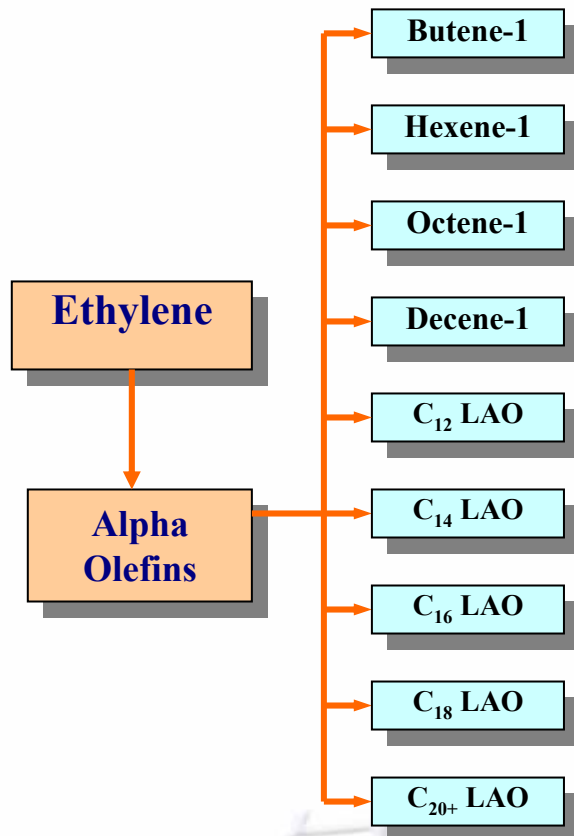

تخطط شركة (سابق) عن طريق إحدى شركاتها (شركة الجبيل المتحدة للبتروكيماويات) للبدء في إنتاج (أوليفينات ألفا الخطية) في الربع الثالث من عام 2006 م بطاقة إنتاجية تصل إلى 150,000 طن متري في مدينة الجبيل الصناعية وذلك باستخدام تقنية (ألفا سابلين) التي طورتها (سابق) مع شركة (ليندي) الألمانية.



PARCI

معهد الأمير عبد الله للبحوث والدراسات الاستشارية  
PRINCE ABDULLAH RESEARCH & CONSULTING INSTITUTE

## Product distribution of LAOs using $\alpha$ -SABLIN technology (percent)

Carbon Chain-length	Percent of total capacity
C <sub>4</sub>	27
C <sub>6</sub>	23
C <sub>8</sub>	18
C <sub>10</sub>	11
C <sub>12</sub>	8
C <sub>14-18</sub>	10
C <sub>20+</sub>	3

# TECHNICAL AND ENGINEERING EVALUATION



PARCI

معهد الأمير عبد الله للبحوث والدراسات الاستشارية  
PRINCE ABDULLAH RESEARCH & CONSULTING INSTITUTE

1. Evaluating the available technologies for the production of ASA from LAO. A proper technology for Saudi Arabia will be selected.
2. Calculating the mass and energy balances of ASA process to determine the requirements of raw materials, utilities, catalysts, etc.
3. Designing the process equipment.
4. Providing a complete description of the process equipment.
5. Determining the companies that have patents for this process.
6. Cost estimation of all equipment and machineries of this process.
7. Cost estimation of raw materials, utilities, additives, chemicals, labor, etc.
8. Calculating the plant energy cost.
9. Calculating the required cooling water and process water.
10. Calculating the costs of off-site facilities.
11. Calculating the transportation and handling costs.
12. Calculating the plant overhead costs.
13. Calculating the administration expenses.
14. Calculating the start-up costs and the operating costs.



PARCI

معهد الأمير عبد الله للبحوث والدراسات الاستشارية  
PRINCE ABDULLAH RESEARCH & CONSULTING INSTITUTE

## المشاريع التي تم إنجازها لصالح شركة "سابك"

1. **SYNTHESIS OF DODECENYL SUCCINIC ANHYDRIDE (DDSA) FROM  $C_{12}$   $\alpha$ -OLEFIN. (Project No. 151)**
2. **SYNTHESIS OF TETRADECENYL SUCCINIC ANHYDRIDE (TDSA), HEXADECENYL SUCCINIC ANHYDRIDE (HDSA) AND OCTADECENYL SUCCINIC ANHYDRIDE (ODSA) FROM  $C_{14}$  -18  $\alpha$  -OLEFINS. (Project No. 152)**
3. **PRODUCTION OF DODECYL DIMETHYLAMINE FROM  $C_{12}$   $\alpha$ -OLEFIN. (Project No. 153)**
4. **PRODUCTION OF TETRADECYL DIMETHYL AMINE, HEXADECYL DIMETHYL AMINE AND OCTADECYL DIMETHYL AMINE FROM  $C_{14}$  -18  $\alpha$  -OLEFINS. (Project No. 154)**



PARCI

معهد الأمير عبد الله للبحوث والدراسات الاستشارية  
PRINCE ABDULLAH RESEARCH & CONSULTING INSTITUTE

## نموذج مبسط لأحد المشاريع المنجزة

إنتاج مادة ASA من ألفا أوليفين الخطية  
في المملكة العربية السعودية



PARCI

معهد الأمير عبد الله للبحوث والدراسات الاستشارية  
PRINCE ABDULLAH RESEARCH & CONSULTING INSTITUTE

# ASA Production

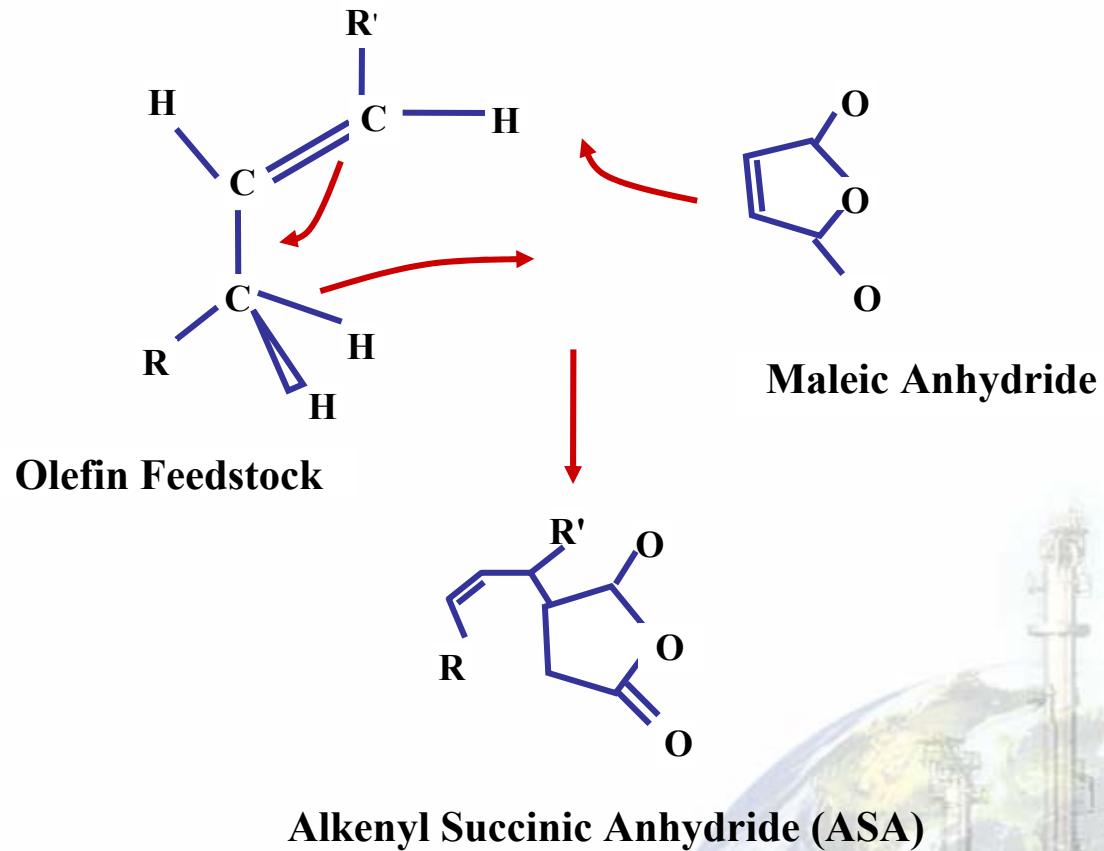



PARCI

معهد الأمير عبد الله للبحوث والدراسات الاستشارية  
PRINCE ABDULLAH RESEARCH & CONSULTING INSTITUTE

## Block Diagram of Alkenyl Succinic Anhydride Manufacturing Process

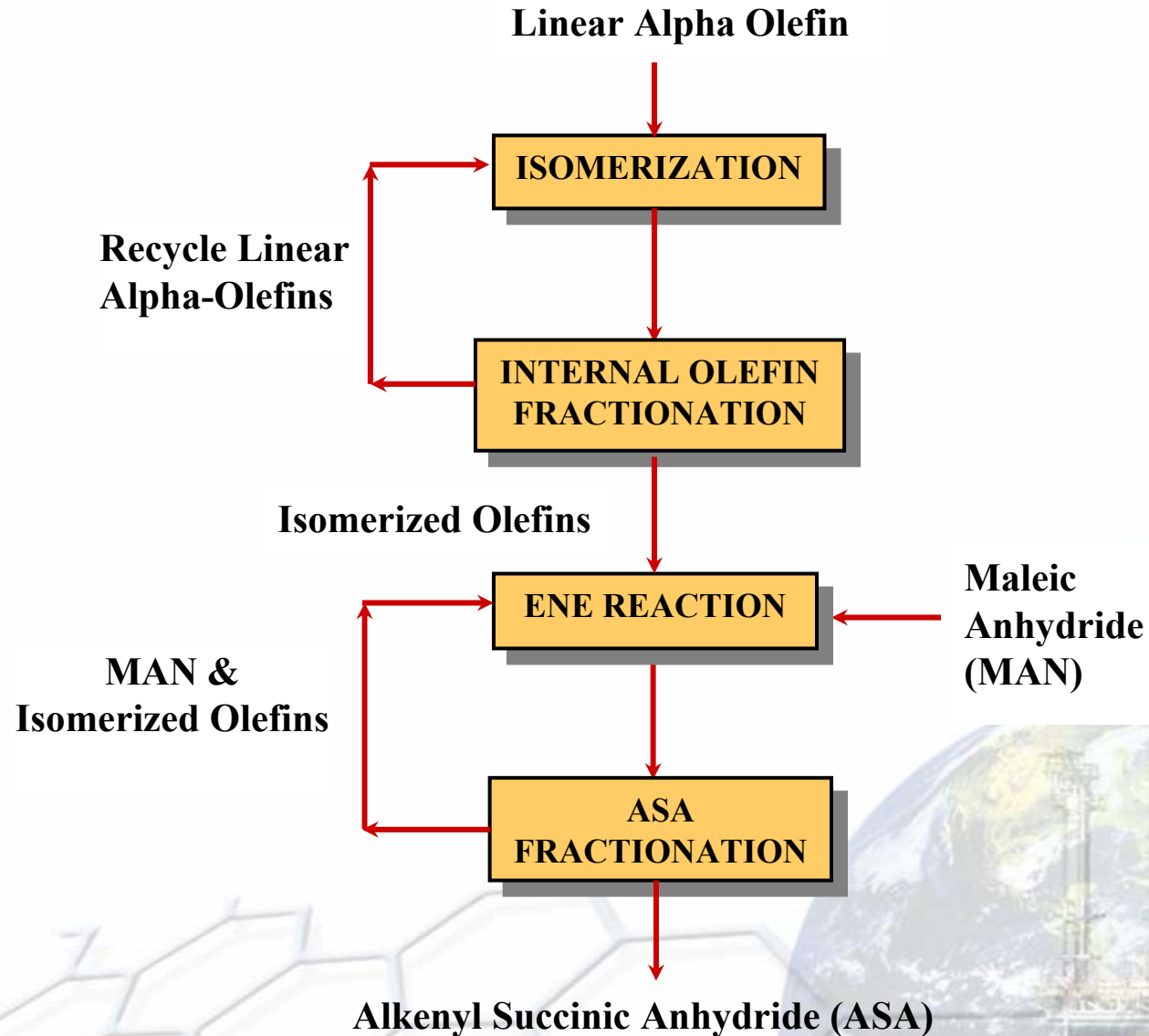



PARCI

معهد الأمير عبد الله للبحوث والدراسات الاستشارية  
PRINCE ABDULLAH RESEARCH & CONSULTING INSTITUTE

# تصميم ومحاكاة العملية الصناعية

Dodeceny Succinic Anhydride Plant

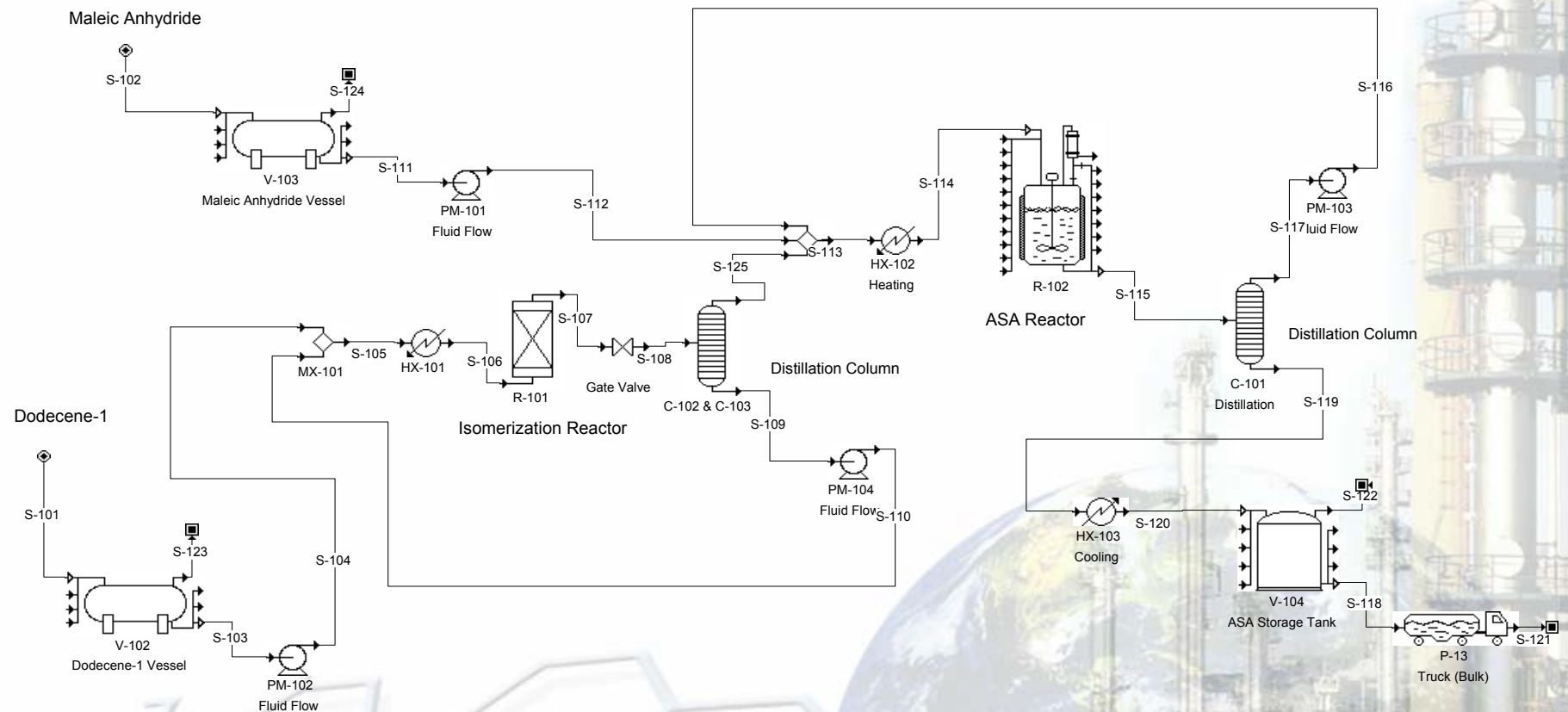



PARCI

معهد الأمير عبد الله للبحوث والدراسات الاستشارية  
PRINCE ABDULLAH RESEARCH & CONSULTING INSTITUTE

# نجاح التعاون

## اكتمال المشاريع

- تم عمل كافة الدراسات الفنية الهندسية اللازمة للمشاريع البتروكيميائية.
- تم عمل الدراسات الاقتصادية والتسويقية لهذه المشاريع البتروكيميائية.

إشادة من المسؤولين في سابك

" أعتزم الفرصة لأشيد بالمستوى المتقدم للدراسات التي أجريتموها، وهو ما أكده الزملاء في قطاع الأوليفينات...."

مدير عام القطاع الخاص بشركة سابك



PARCI

معهد الأمير عبد الله للبحوث والدراسات الاستشارية  
PRINCE ABDULLAH RESEARCH & CONSULTING INSTITUTE

# خاتمة

من مقومات نجاح التعاون بين الجامعة والقطاع الخاص :

- معرفة احتياجات القطاع الخاص من قبل المتخصصين في مراكز البحوث.
- المبادرة من مراكز البحوث لتقديم الخدمات.
- التعاون الكامل أثناء الدراسة بين الباحث والقطاع الخاص للوصول للنتائج المرجوة.
- دعم القطاع الخاص لمراكز البحوث في الجامعات.