

Final Exam

Problem (1)

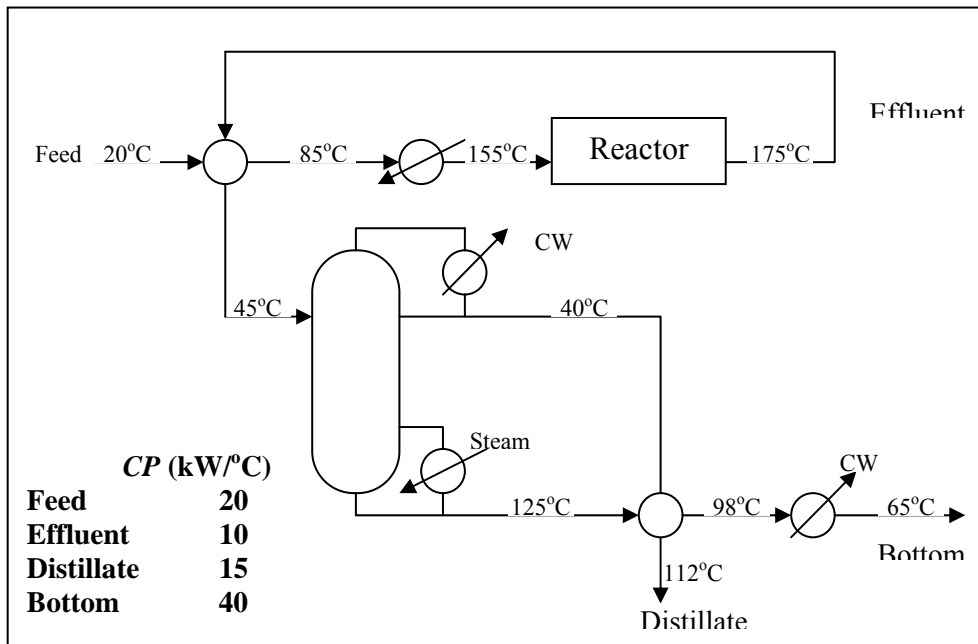

For the above process-flow-diagram (PFD), determine the following:

- The grid representation of the hot and cold streams of the process.
- Solve for the minimum targets using the problem table approach.
- What is the minimum number of heat exchangers based on MER.
- Design a heat exchanger network based on the minimum targets (*Hint*: you may need to perform stream splitting).

The minimum approach temperature, ΔT_{\min} is 13 °C.

Problem (2)

a. Find the minimum utility requirements for a network of heat exchangers involving the following streams:

Process	Temperature, °C		Heat-Capacity Flow Rate, CP (Btu/hr °F * 10 ⁻⁴)
	Supply	Target	
1	100	430	1.6
2	180	350	3.27
3	200	400	2.6
4	440	150	2.8
5	520	300	2.38
6	390	150	3.36

The minimum approach temperature, ΔT_{\min} is 18 °F.

b. Draw the grand composite curve and give one suggestion for cost saving.