

MECHANISM OF ELECTRICAL CONDUCTION

Mechanism of electrical conduction in Materials the conduction of electricity through materials can be accomplished by three means :

- a) The flow of electrons Ex. In Metal
- b) The flow of ions Ex. Salt water .
- c) Polarization in which ions or electrons move only a short distance under the influence of an electric field and then stop.

1 Metals :

Conduction by the flow of electrons depends upon the availability of free electrons. If there is a large number of free electrons available, then the material is called a metal, the number of free electrons in a metal is roughly equal to the number of atoms.

The number of conduction electrons is proportional to a factor

$$n \approx \epsilon^{E/KT} \quad E \propto 1/n \quad T \propto n$$

ϵ : Dielectric constant

K: Boltzman's constant

T: Absolute Temperature.

E Activation Energy.

Metals may be considered a special class of electron semi conductor for which E approaches zero.

Among earth materials native gold and copper are true metals. Most sulfide ore minerals are electron semi conductors with such a low activation energy.

b) The flow of ions, is best exemplified by conduction through water, especially water with appreciable salinity. So that there is an abundance of free ions.

Most earth materials conduct electricity by the motion of ions contained in the water within the pore spaces .

There are three exceptions :

- 1) The sulfide ores which are electron semi conductors.
- 2) Completely frozen rock or completely dry rock.
- 3) Rock with negligible pore spaces (Massive Igneous rocks like gabbro . It also include all rocks at depths greater than a few kilometers, where pore spaces have been closed by high pressure, thus studies involving conductivity of the deep crust and mantle require other mechanisms than ion flow through connate water.

c) Polarization of ions or sometimes electrons under the influence of an electrical field, they move a short distance then stop. Ex. Polarization of the dielectric in a condenser polarization (electrical moment / unit volume)

Conductivity mechanism in non-water-bearing rocks

- 1) Extrinsic conductivity for low temperatures below 600-750° k.
- 2) Intrinsic conductivity for high temperatures.

Most electrical exploration will be concerned only with temperatures well below 600-750°. The extrinsic is due to weakly bonded impurities or defects in the crystal. This is therefore sensitive to the structure of the sample and to its thermal history.

Both of these types of conductivity present the same functional form, hence conductivity vs temperature for semi conductors can be written :

$$\sigma = A_i \varepsilon^{-E_i/RT} + A_e \varepsilon^{-E_e/RT}$$

A_i and A_e : Numbers of ions available . A_i is 10^5 times A_e

E_i and E_e are the activation energies . E_i is 2 times as large as E_e .
 R : Boltzman's constant

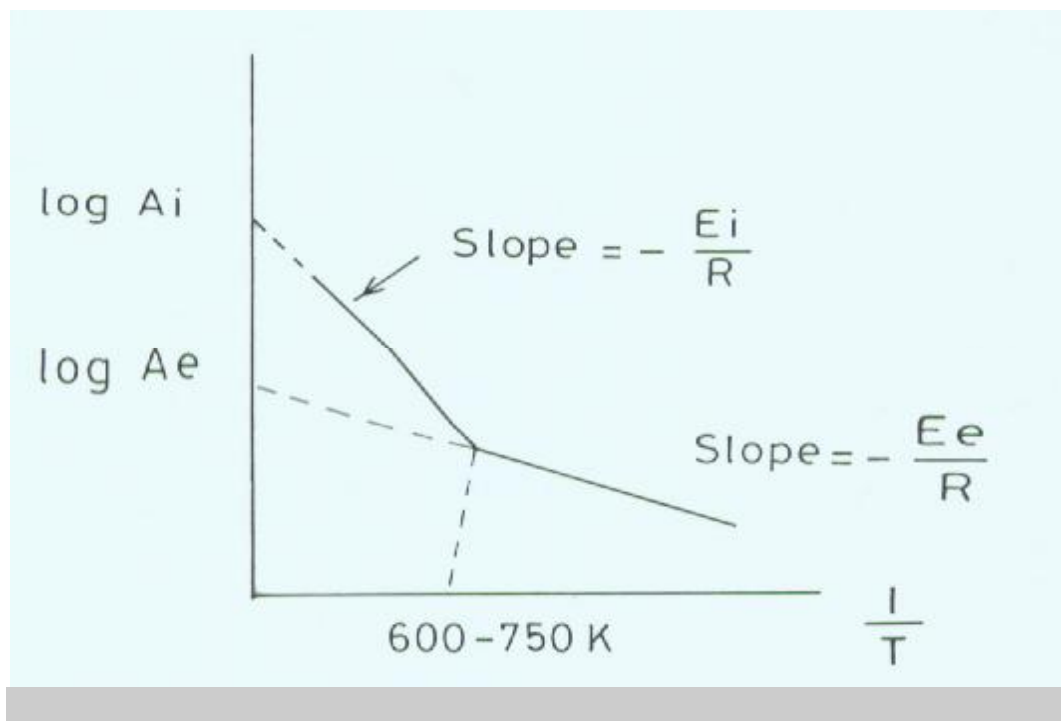

ELECTRICAL PROPERTIES OF ROCKS :

- ✓ Resistivity (or conductivity), which governs the amount of current that passes when a potential difference is created.
- ✓ Electrochemical activity or polarizability, the response of certain minerals to electrolytes in the ground, the bases for SP and IP.
- ✓ Dielectric constant or permittivity. A measure of the capacity of a material to store charge when an electric field is applied . It measure the polarizability of a material in an electric field $= 1 + 4 \pi X$
X : electrical susceptibility .

Electrical methods utilize direct current or Low frequency alternating current to investigate electrical properties of the subsurface.

Electromagnetic methods use alternating electromagnetic field of high frequencies.

Two properties are of primary concern in the Application of electrical methods.

- (1) The ability of Rocks to conduct an electrical current.
- (2) The polarization which occurs when an electrical current is passed through them (IP).

Resistivity

For a uniform wire or cube, resistance is proportional to length and inversely proportional to cross-sectional area. Resistivity is related to resistance but it not identical to it. The resistance R depends an length, Area and properties of the material which we term resistivity (ohm.m) .

Constant of proportionality is called Resistivity :

$$R = \rho \frac{L}{A}$$

Resistivity is the fundamental physical property of the metal in the wire

$$\rho = \frac{VA}{IL}$$

Resistivity is measured in ohm-m

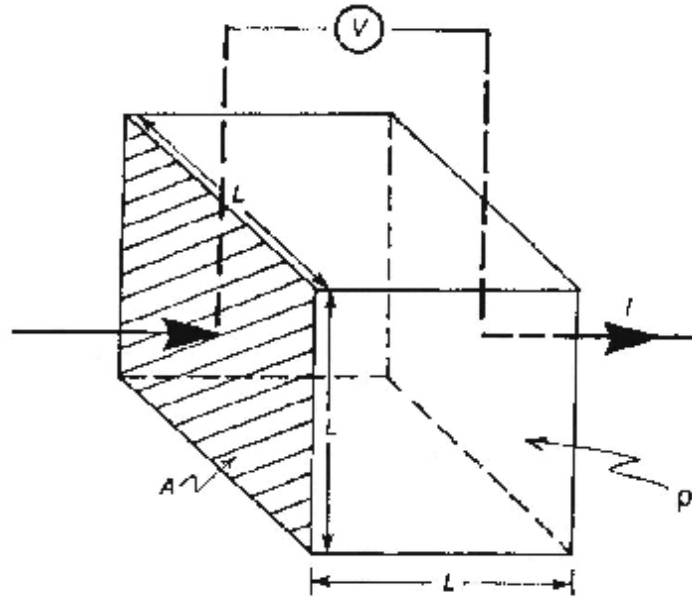

Conductivity is defined as $1/\rho$ and is measured in Siemens per meter (S/m), equivalent to $\text{ohm}^{-1}\text{m}^{-1}$.

EX. 1 Copper has $\rho = 1.7 \times 10^{-8}$ ohm.m. What is the resistance of 20 m of copper with a cross-sectional radius of 0.005m .

EX. Quartz has $\rho = 1 \times 10^{16}$ ohm.m. What is the resistance at a quartz wire at the same dimension.

Anisotropy : is a characteristic of stratified rocks which is generally more conducive in the bedding plane. The anisotropy might be find in a schist

(micro anisotropic) or in a large scale as in layered sequence of shale (macro anisotropic) .

هو النسبة بين الحد الأقصى للمقاومية إلى الحد الأدنى ويصل ما بين 1-1 و10 هذا يعني انه لو طبق التيار في اتجاه واحد فان هذا المعامل يقوم بتغيير الصفات الخواص الكهربائية للاتجاه الآخر .

Coefficient of anisotropy $\lambda = \rho_t / \rho_l$
 ρ_l : Longitudinal Resistivity .
 ρ_t : Transverse Resistivity.

The effective Resistivity depends on whether the current is flowing parallel to the layering or perpendicular to it .

$$R_1 = \rho_l h_l$$

The total Resistance for the unit column (T)

$$T = \sum \rho_l h_l \quad \text{Transverse unit resistance}$$

The transverse resistivity ρ_t is defined by .

$$\rho_t = T/H \quad H \text{ is the total thickness}$$

For current flowing horizontally, we have a parallel circuit. The reciprocal resistance is $S = 1/R = \sum h_i / \rho_i$ Longitudinal unit conductance

$$\text{Longitudinal resistivity } \rho_l = H / S$$

A geoelectric unit is characterized by two Parameters :

- 1) Layer Resistivity (ρ_i)
- 2) Layer Thickness(t_i)

Four electrical parameters can be derived for each layer from the respective resistivity and thickness. There are :

- 1) Longitudinal conductance $S_L = h/\rho = h \cdot \sigma$
- 2) Transverse resistance $T = h \cdot \rho$
- 3) Longitudinal resistivity $\rho_l = h/S$

4) Transverse resistivity $\rho_t = T/h$

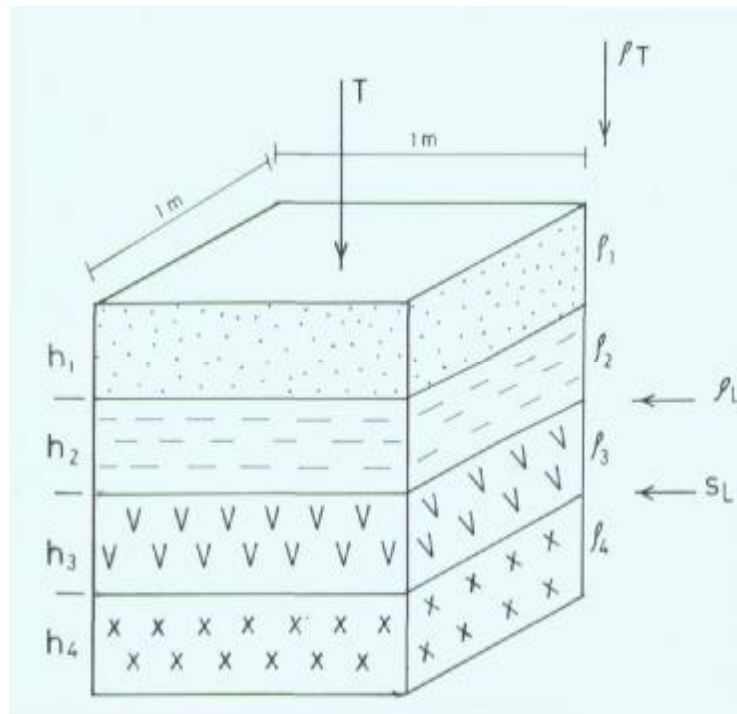

Anisotropy = $A = \text{Transverse resistivity } \rho_t / \text{Longitudinal resistivity } \rho_l$

The sums of all S_L ($\sum h_i / \rho_i$) are called Dar Zarrouk functions.
 The sums of all T ($\sum h_i \cdot \rho_i$) are called Dar Zarrouk variables.

Classification of Materials according to Resistivities Values

- a) Materials which lack pore spaces will show high resistivity such as
 - massive limestone
 - most igneous and metamorphic (granite, basalt)

- b) Materials whose pore space lacks water will show high resistivity such as :
 - dry sand and gravel

- Ice .
- c) Materials whose connate water is clean (free from salinity) will show high resistivity such as :
 - clean sand or gravel , even if water saturated.
- d) most other materials will show medium or low resistivity, especially if clay is present such as :
 - clay soil
 - weathered rock.

The presence of clay minerals tends to decrease the Resistivity because :

- 2) The clay minerals can combine with water .
- 3) The clay minerals can absorb cations in an exchangeable state on the surface.
- 4) The clay minerals tend to ionize and contribute to the supply of free ions.

Factors which control the Resistivity

- (1) Geologic Age
- (2) Salinity.
- (3) Free-ion content of the connate water.
- (4) Interconnection of the pore spaces (Permeability).
- (5) Temperature.
- (6) Porosity.
- (7) Pressure
- (8) Depth

Archie's Law

Empirical relationship defining bulk resistivity of a saturated porous rock. In sedimentary rocks, resistivity of pore fluid is probably single most important factor controlling resistivity of whole rock.

Archie (1942) developed empirical formula for effective resistivity of rock:

$$\rho_0 = a\rho_w\phi^{-m}$$

ρ_0 = **bulk rock resistivity**

ρ_w = *pore-water resistivity*

a = empirical constant ($0.6 < a < 1$)

m = *cementation factor* (1.3 poor, unconsolidated) $< m < 2.2$
(good, cemented or crystalline)

ϕ = *fractional porosity* (vol liq. / vol rock)

Formation Factor:

$$F = \frac{\rho_0}{\rho_w} = a\phi^{-m}$$

Effects of Partial Saturation:

$$\rho_t = S_w^{-n} a\rho_w\phi^{-m}$$

S_w is the volumetric saturation.

n is the *saturation coefficient* ($1.5 < n < 2.5$).

- Archie's Law ignores the effect of pore geometry, but is a reasonable approximation in many sedimentary rocks

Resistivity survey instruments:

- a- High tension battery pack (source of current).
- b- Four metal stakes.
- c- Milliammeter.
- d- Voltmeter.
- e- Four reels of insulated cable.

AC is preferred over DC as source of current. The advantage of using AC is that unwanted potential can be avoided.

Field considerations for DC Resistivity

- 1- Good electrode contact with the earth
 - Wet electrode location.
 - Add NaCl solution or bentonite
- 2- Surveys should be conducted along a straight line whenever possible .
- 3- Try to stay away from cultural features whenever possible .
 - Power lines
 - Pipes
 - Ground metal fences
 - Pumps

Sources of Noise

There are a number of sources of noise that can effect our measurements of voltage and current.

1- Electrode polarization.

A metallic electrode like a copper or steel rod in contact with an electrolyte groundwater other than a saturated solution of one of its own salt will generate a measurable contact potential. For DC Resistivity, use nonpolarizing electrodes. Copper and copper sulfate solutions are commonly used.

2- Telluric currents.

Naturally existing current flow within the earth. By periodically reversing the current from the current electrodes or by employing a slowly varying AC current, the affects of telluric can be cancelled.

3- Presence of nearby conductors. (Pipes, fences)

Act as electrical shorts in the system and current will flow along these structures rather than flowing through the earth.

4- Low resistivity at the near surface.

If the near surface has a low resistivity, it is difficult to get current to flow more deeply within the earth.

5- Near- electrode Geology and Topography

Rugged topography will act to concentrate current flow in valleys and disperse current flow on hills.

6- Electrical Anisotropy.

Different resistivity if measured parallel to the bedding plane compared to perpendicular to it .

7- Instrumental Noise .

8- Cultural Feature .

Current Flow in Uniform Earth with Two Electrodes

Current injected by electrode at S_1 and exits by electrode at S_2 :

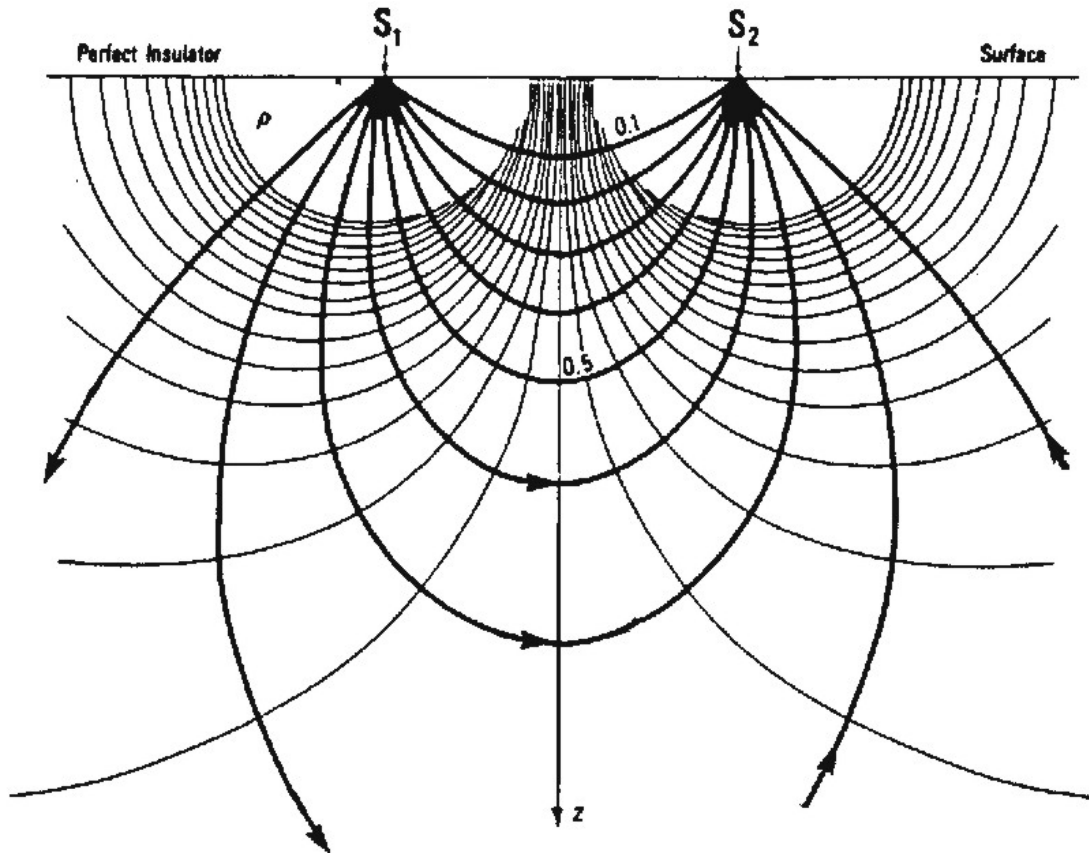

Lines of constant potential (equipotential) are no longer spherical shells, but can be calculated from expression derived previously.

Current flow is always perpendicular to equipotential lines.

- Where ground is uniform, measured resistivity should not change with electrode configuration and surface location.
- Where inhomogeneity present, resistivity varies with electrode position. Computed value is called apparent resistivity ρ_A .

Current Flow in A Homogeneous Earth

1. Point current Source :

If we define a very thin shell of thickness dr we can define the potential different dv

$$dv = I (R) = I (\rho L / A) = I (\rho dr / 2\pi r^2)$$

To determine V at a point . We integrate the above eq. over its distance D to to infinity :

$$V = I \rho / 2\pi D$$

C : current density per unit of cross sectional area :

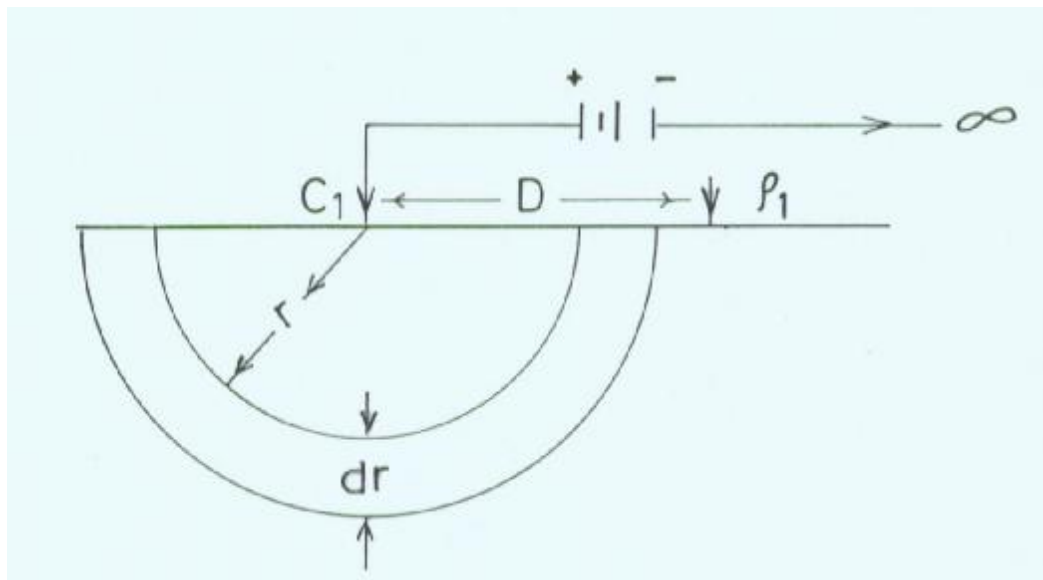

2. Two current electrodes

To determine the current flow in a homogeneous, isotropic earth

When we have two current electrodes. The current must flow from the positive (source) to the resistive (sink).

The effect of the source at C1 (+) and the sink at C2 (-)

$$V_{p1} = i \rho / 2\pi r_1 + (- i \rho / 2\pi r_2)$$

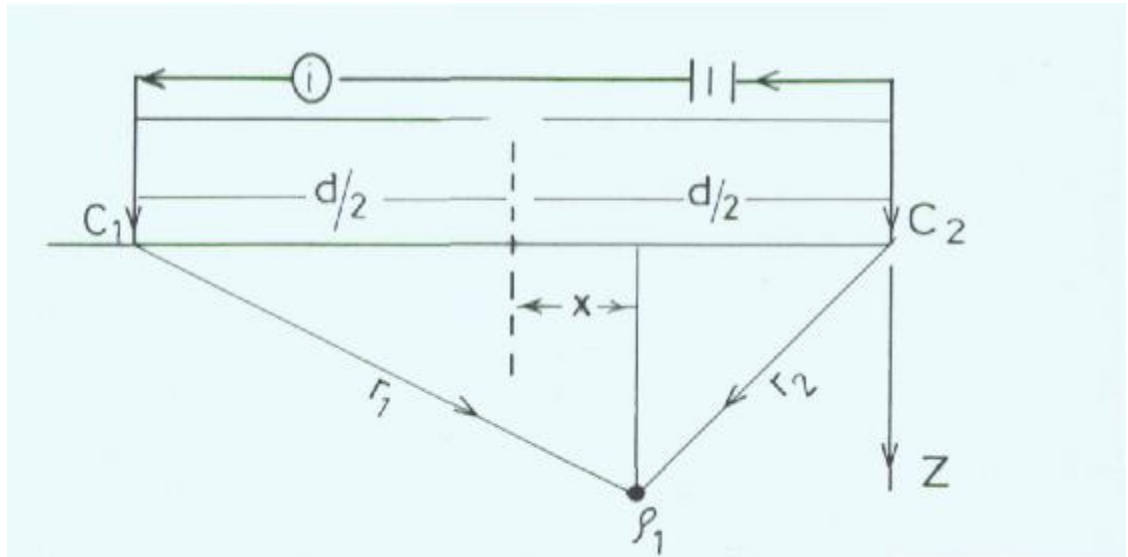

$$V_{p1} = i \rho / 2\pi \{ 1 / [(d/2 + x)^2 + Z^2]^{0.5} - 1 / [(d/2 - x)^2 + Z^2]^{0.5} \}$$

3. Two potential Electrodes

$$V_{p_1} = i \rho / 2\pi r_1 - i \rho / 2\pi r_2$$

$$V_{p_2} = i \rho / 2\pi r_3 - i \rho / 2\pi r_4$$

$$\Delta V = V_{p_1} - V_{p_2} = i \rho / 2\pi (1/r_1 - 1/r_2 - 1/r_3 + 1/r_4)$$

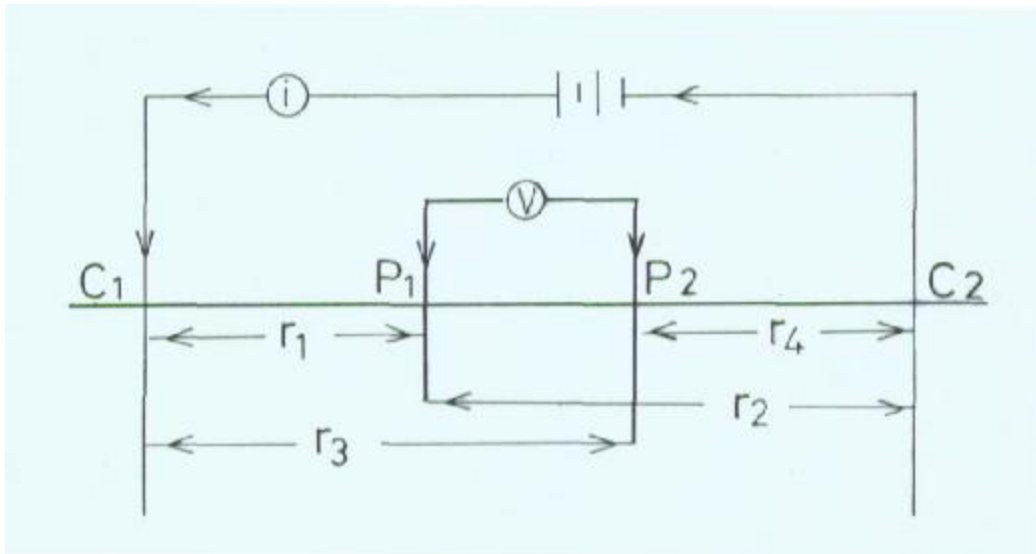

Depth of Current Penetration

Current flow tends to occur close to the surface. Current penetration can be increased by increasing separation of current electrodes. Proportion of current flowing beneath depth z as a function of current electrode separation AB :

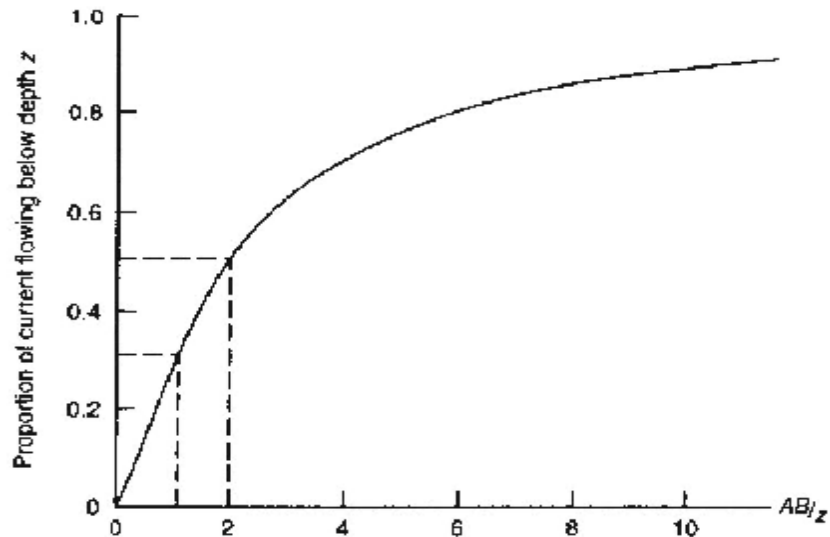

Example

If target depth equals electrode separation, only 30% of current flows beneath that level.

- To energize a target, electrode separation typically needs to be 2-3 times its depth.
- High electrode separations limited by practicality of working with long cable lengths. Separations usually less than 1 km.

The fraction of the total current (if) penetrating to depth Z for an electrode separation of d is given by :

$$if = \frac{2}{\pi} \tan^{-1} \left(\frac{2Z}{d} \right)$$

